



PETRO ARTAN PART

- NEEDLE VALVES
- MANIFOLDS
- BALL VALVES
- BLOCK & BLEED VALVES
- GATE VALVES
- GLOBE VALVES

Office:

Unit1, No.102, Karimkhan Zand St.,

Tehran, Iran

Tel-Fax: +9821-88832570

info@Petro-Artan.com

www.Petro-Artan.com

Introduction:

Petro artan part is a high-tech manufacturing group. We have a strong focus on enhancing customer productivity and sustainability through our unique expertise and solutions for oil & gas refineries, petrochemicals, power plants and chemical industries.

Our offering covers value chains and is based on extensive investment in research and development (R&D). our products category consists of mechanical instruments such as high pressure Valves, strainer, condensate pot, flange, pipe fitting, sample connections, sample cooler, sample point, seal pot , separation and filtration systems.

The manufacturing facilities – factories and workshops – a 24,000 square-meter is located in 5 different areas. Along with sales offices in the heart of Tehran city.

we apply our expert minds and collaborative ways of working with customers to build more resilient and stronger businesses trying to deliver different products category in a short possible time.

Due to ability of producing products in variety of materials, sizes, pressures and etc. all items can be manufactured according to customers' demand.

To support our customer's needs, PAP Co. owns supplying departments which import the best products related to its work field, from global companies and agents.

PAP Co is approved and listed among the Ministry of petroleum AVL (MOP AVL) and National petrochemical company (NPC AVL). this clearly means the wide range of our products have been tested and used in refineries and petrochemical sites for several years and makes customers to do business with us with great confidence.

Petro Artan Part Co. Coding System

1	2	3	4	5	6	7	8	9
Type	Body	Connection	Pressure Rating	Size	Material	Seat	Bore	Treatment

Type	1
BA	Ball
GA	Gate
GO	Globe
SC	Swing Check
PC	Piston Check
YC	Y Type Check
LC	Lift Check
NE	Needle

Body	2
W	Welded Bonnet
B	Bolted Bonnet
G	Globe Pattern
A	Angle Pattern
1	One Pieces
2	Two Pieces
3	Three Pieces

Connection	3
NN	NPT(F) X NPT(F)
MM	NPT(M) X NPT(M)
UU	Butt Weld X Butt Weld
CC	Socket Weld X Socket Weld
LL	Plain End X Plain End
OO	Tube Nut X Tube Nut
FF	Flanged X Flanged
NM	NPT(F) X NPT(M)
NC	NPT(F) X Socket Weld

Rating	4
3M	3000Psi
6M	6000Psi
10M	10000Psi
1W	1000WOG
2W	2000WOG
1C	#150
2C	#300
3C	#600
4C	#800
5C	#1500
...	...

Size	5	
	inch	mm
3m		3
6m		6
9m		9
002	1/8	10.3
004	1/4	13.7
006	3/8	17.10
008	1/2	21.30
012	3/4	26.70
016	1	33.40
020	1,1/4	42.20
024	1,1/2	48.30
032	2	60.3
048	3	88.9
064	4	114.3
096	6	168.30
128	8	219.1
160	10	273.1
192	12	323.9

Material	6
01	A105N
02	A350 LF2
03	A182-F11
04	A182-F5
05	A182-F304
06	A182-F304L
07	A182-F316
08	A182-F316L
09	A182-F321
10	A182-F51
11	A182-F53
12	A182-F6a
13	A564 UNS S17400
14	B564 No4400
15	B649

Seat Material	7
50	P.T.F.E
51	R.P.T.F.E/Glass
52	R.P.T.F.E/Carbon Graphite
53	POM
54	PEEK
55	NYLON 12
56	NYLON 1010
57	NYLON 6
58	FKM
59	NBR
60	Silicon
61	Graphite
62	EPDM
63	Kel-f

Bore	8
F	Full Bore
R	Reduced Bore

Treatment	9
NT	No Treatment
NR	Normalized
QT	Quenched & Tempered
AN	Anealed
SA	Solution Anealed
NP	Electroless Ni. Plated
CP	Cr. Plated
PH	Phosphate
GZ	Galvanized
PI	Pickled
...	...

NEEDLE VALVE

OD (TUBE END CONNECTIONS)

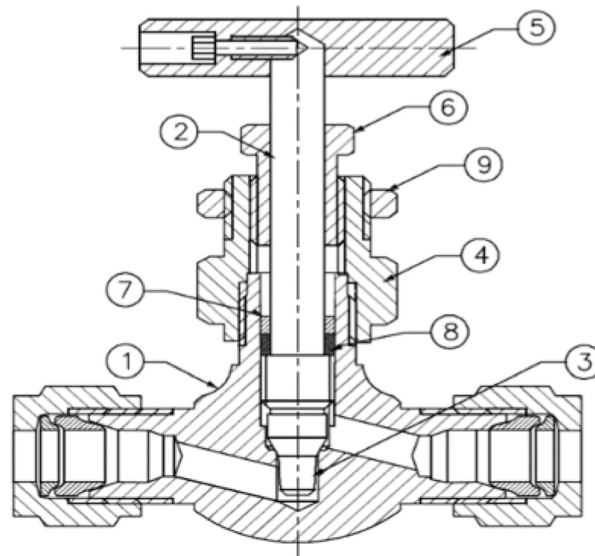

Materials of Construction		
ROW	DESCRIPTION	MATERIAL
1	BODY	316L STAINLESS STEEL
2	STEM	316L STAINLESS STEEL
3	STEM TIP	17-4PH STAINLESS STEEL
4	BONNET	316L STAINLESS STEEL
5	HANDLE	STAINLESS STEEL
6	PANEL MOUNTING NUT	316L STAINLESS STEEL
7	RING	316L STAINLESS STEEL
8	STEM PACKING	PTFE + GRAPHIT
9	BONNET NUT	316L STAINLESS STEEL

NEEDLE VALVE (Bar Stock)

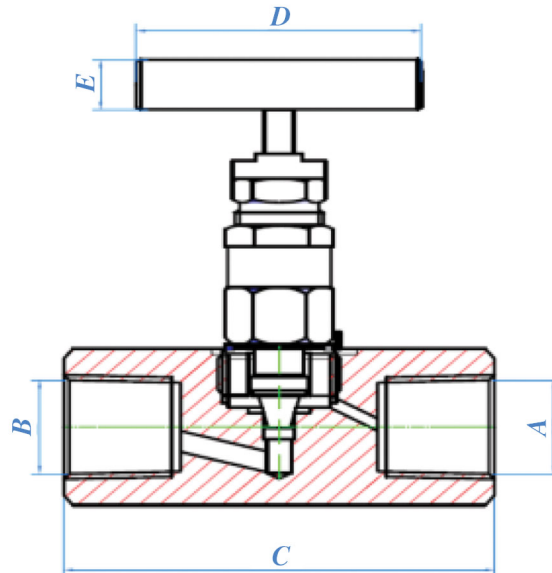

PAP Part Number	Working Pressure	End Connection		Dimerions				
		Inlet	Outlet	A NPT (Female)	B NPT	C(mm)	D(mm)	E
NVS 4FF	3000 6000 10000 Psi	1/4"NPT Female	1/4"NPT Female	1/4"	1/4" Male	55	58	Ø13
NVS 6FF		3/8"NPT Female	3/8"NPT Female	3/8"	3/8" Male	59	58	Ø13
NVS 8FF		1/2"NPT Female	1/2"NPT Female	1/2"	1/2" Male	65	58	Ø13
NVS 4M4F		1/4" NPT Male	1/4" NPT Female	1/4"	1/4" Male	55	58	Ø13
NVS 6M6F		3/8" NPT Male	3/8" NPT Female	3/8"	3/8" Male	59	58	Ø13
NVS 8M8F		1/2" NPT Male	1/2" NPT Female	1/2"	1/2" Female	65	58	Ø13
NVS 12FF		3/4" NPT Female	3/4" NPT Female	3/4"	3/4" Female	65	58	Ø13
NVS 16FF		1"NPT Female	1" NPT Female	1"	1" Female	86	58	Ø13
NVS 12M8F		3/4" NPT Male	1/2" NPT Female	1/2"	3/4" Male	70	58	Ø13
NVS 12M12F		3/4" NPT Male	3/4" NPT Female	3/4"	3/4" Male	70	58	Ø13

NEEDLE VALVE (With down Stream Vent)

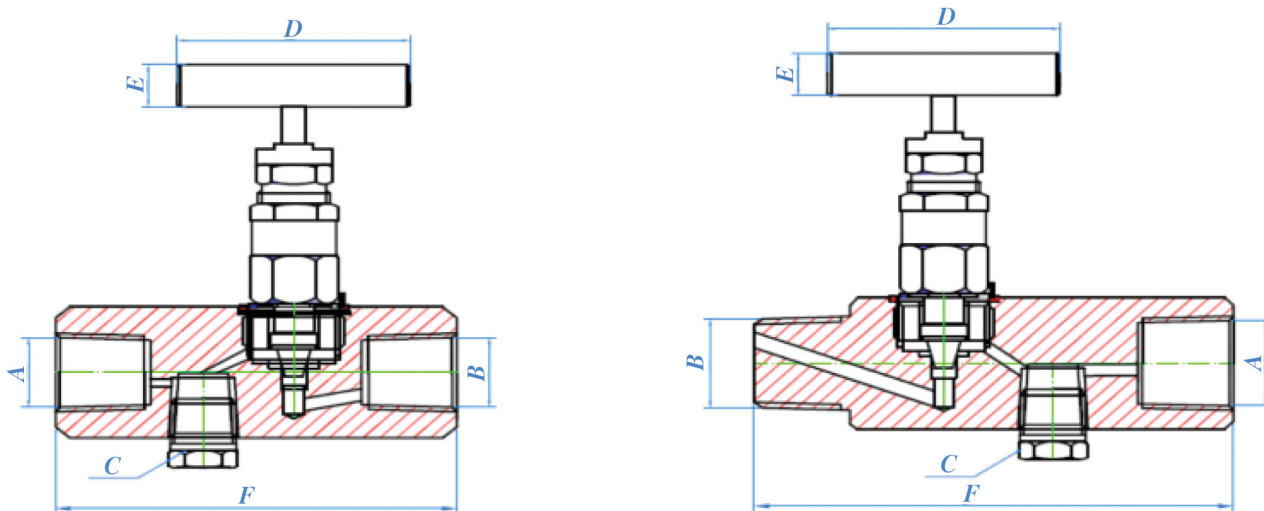

PAP Part Number	Working Pressure	End Connection		Dimensions					
		Inlet	Outlet	A NPT (F)	B NPT (M)	C (Vent) NPT	D (mm)	E	F(mm)
NVS 4FFV	3000 6000 10000 Psi	1/4" NPT Female	1/4" NPT Female	1/4"	1/4"	1/4"	58	Ø13	90.5
NVS 8FFV		1/2"NPT Female	1/2" NPT Female	1/2"	1/2"	1/4"	58	Ø13	90.5
NVS 12FFV		3/4" NPT Female	3/4" NPT Female	3/4"	3/4"	1/4"	58	Ø14	90.5
NVS 4M4FV		1/4"NPT Male	1/4"NPT Female	1/4"	1/4"	1/4"	58	Ø13	90.5
NVS 8M8FV		1/2"NPT Male	1/2"NPT Female	1/2"	1/2"	1/4"	58	Ø13	90.5
NVS 12M12FV		3/4"NPT Male	3/4" NPT Female	3/4"	3/4"	1/4"	58	Ø14	90.5

NEEDLE VALVE (Bar Stock)

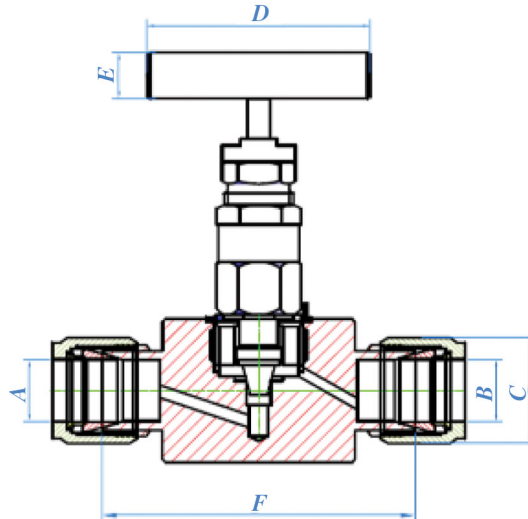

PAP Part Number	Working Pressure	End Connection		Dimension:					
		Inlet Tube O.D	Outlet Tube O.D	A Tube O.D	B Tube O.D	C	D(mm)	E	F(mm)
NVS 4A	3000 6000 10000 Psi	1/4"	1/4"	1/4"	1/4"	Hex 14	58	Ø13	50
NVS 6A		3/8"	3/8"	3/8"	3/8"	Hex 17	58	Ø13	55
NVS 8A		1/2"	1/2"	1/2"	1/2"	Hex 22	58	Ø14	65
NVS M6A		6 mm	6 mm	6 mm	6 mm	Hex 14	58	Ø13	50
NVS M10A		10 mm	10 mm	10mm	10mm	Hex 17	58	Ø13	55
NVS M12A		12mm	12mm	12mm	12mm	Hex 22	58	Ø13	65

NEEDLE VALVE

(Multi-Port Gauge Valve)

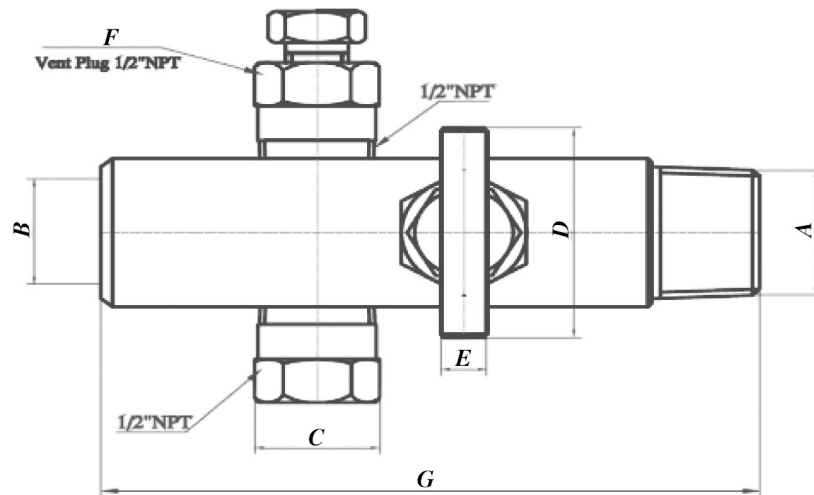

PAP Part Number	Working Pressure	End Connection		Dimensions						
		Inlet NPT Male	Outlet NPT Female	A NPT (M)	B NPT (M)	C Plug NPT	D(mm)	E	F Vent Plug NPT	G(mm)
GVS 8	3000 6000	1/2"	3x1/2"	1/2"	1/2"	Plug 1/2"	58	Ø13	1/2"	120
GVS 12	10000 Psi	3/4"	3x1/2"	3/4"	1/2"	1/2"	58	Ø13	1/2"	120

NEEDLE VALVE

O.D (Tube End Connection), Globe Pattern

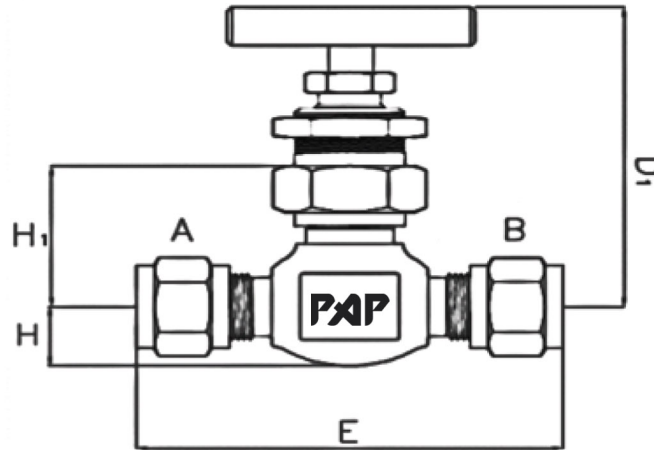

PAP Part Number	Working Pressure	End Connection		Dimensions					
		Inlet	Outlet	Unit	D	D ¹ *	E	H	H ¹ *
NEGOO 10M002	3000 6000 10000 Psi	1/8" TUBE	1/8" TUBE	in	2 7/32	2 3/4	2 1/8	4 19/6	1 1/32
				mm	56	70	54	8	26
NEGMM 10M002		1/8" M-NPT	1/8" M-NPT	in	2 1/8	2 21/32	1 3/4	2 5/64	1 5/16
				mm	54	67	44	10	24
NEGMN 10M002		1/8" M-NPT	1/8" F-NPT	in	2 1/8	2 21/32	1 3/4	2 5/64	1 5/16
				mm	54	67	44	10	24
NEGNN 10M002		1/8" F-NPT	1/8" F-NPT	in	2 1/8	2 21/32	1 3/4	2 5/64	1 5/16
				mm	54	67	44	10	24
NEGOO 10M004		1/4" TUBE	1/4" TUBE	in	2 1/8	2 21/32	2 3/8	2 5/64	1 5/16
				mm	54	67	60	10	24
NEGMO 10M004		1/4" M-NPT	1/4" TUBE	in	2 1/8	2 21/32	2 3/16	2 5/64	1 5/16
				mm	54	67	56	10	24
NEGMM 10M004		1/4" M-NPT	1/4" M-NPT	in	2 1/8	2 21/32	2	2 5/64	1 5/16
				mm	54	67	51	10	24
NEGOO 10M3m		3mm TUBE	3mm TUBE	in	2 3/16	2 3/4	2 1/8	1 9/64	1 1/32
				mm	56	70	54	8	26
NEGOO 10M6m	6mm TUBE	6mm TUBE	in	2 1/8	2 21/32	2 3/8	2 5/64	1 5/16	
			mm	54	67	60	10	24	
NEGOO 10M8m	8mm TUBE	8mm TUBE	in	2.125	2 21/32	2 3/8	2 5/64	1 5/16	
			mm	54	67	60	10	24	

All dimensions could be considered as reference.

* D¹ and H¹ For valves with panel mounting.

NEEDLE VALVE

O.D (Tube End Connection), Angel Pattern

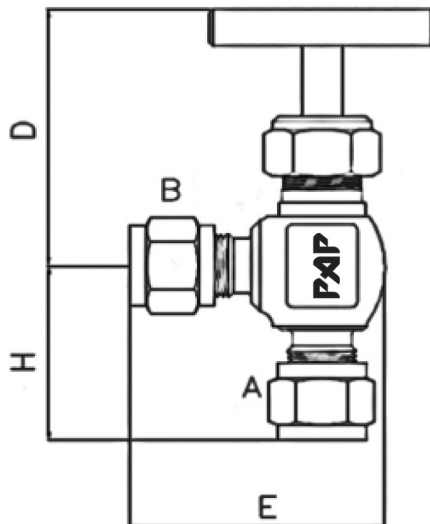

PAP Part Number	Working Pressure	End Connection		Dimensions					
		Inlet	Outlet	Unit	D	D ¹ *	E	H	H ¹ *
NEAOO 10M002	3000 6000 10000Psi	1/8" TUBE	1/8" TUBE	inch	2 7/32	2 3/4	1 1/2	1 1/64	1 1/64
				mm	56	70	38	26	26
NEAMM 10M002		1/8" M-NPT	1/8" M-NPT	inch	2 1/8	2 21/32	1 17/64	7/8	15/16
				mm	54	67	32	22	24
NEANN 10M002		1/8" F-NPT	1/8" F-NPT	inch	2 1/8	2 21/32	1 17/64	7/8	15/16
				mm	54	67	32	22	24
NEAMO 10M002		1/8" M-NPT	1/4" TUBE	inch	2 1/8	2 21/32	1 19/32	7/8	15/16
				mm	54	67	40	22	24
NEAOO 10M004		1/4" TUBE	1/4" TUBE	inch	2 1/8	2 21/32	1 19/32	1 3/16	15/16
				mm	54	67	40	30	24
NEAMO 10M004		1/4" M-NPT	1/4" TUBE	inch	2 1/8	2 21/32	1 19/32	7/8	15/16
				mm	54	67	40	22	24
NEAMM 10M004		1/4" M-NPT	1/4" M-NPT	inch	2 1/8	2 21/32	1 17/64	7/8	15/16
				mm	54	67	32	22	24
NEAOO 10M6m		6mm TUBE	6mm TUBE	inch	2 1/8	2 21/32	1 37/64	1 3/16	15/16
				mm	54	67	40	30	24

All dimensions could be considered as reference.

* D¹ and H¹ For valves with panel mounting.

2Way Manifold for Gauge

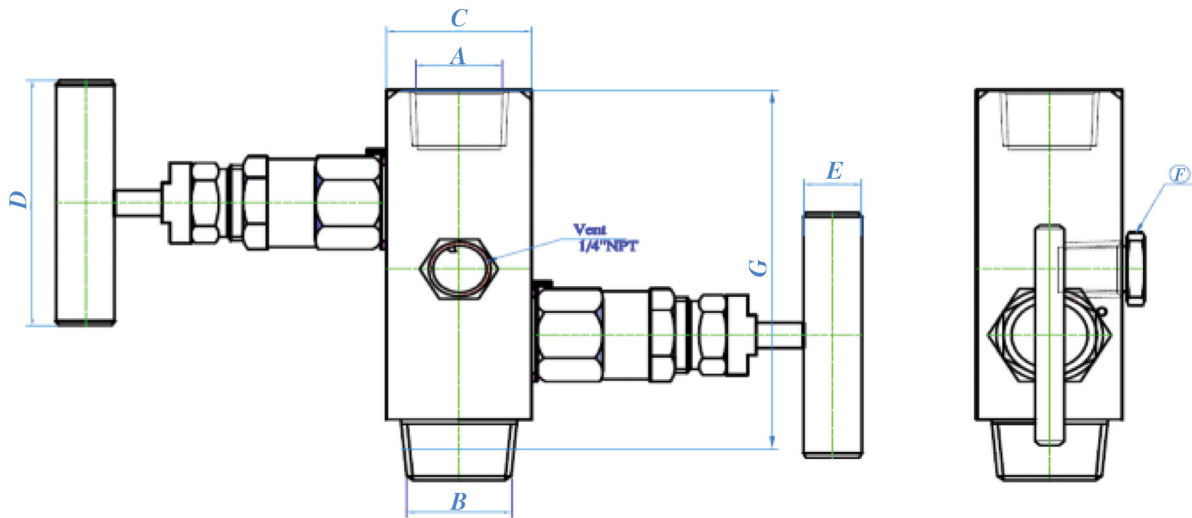

PAP Part Number	Working Pressure	End Connection		Dimensions							
		Inlet NPT	Outlet NPT Female	A NPT (F)	B NPT (M)	C(mm)	D(mm)	E	F Vent NPT	G(mm)	
2VG2NS	3000 6000 10000 Psi	1/4" Male	1/4"	1/4"	1/4"	SQ32×32	58	Ø13	1/4"	89	
2VG4NS		1/2" Male	1/2"	1/2"	1/2"	SQ32×33	58	Ø13	1/4"	95	
2VG2NS-F		1/4" Female	1/4"	1/4"	1/4"	1/4"	SQ32×32	58	Ø13	1/4"	85
2VG4NS-F		1/2" Female	1/2"	1/2"	1/2"	1/2"	SQ32×33	58	Ø13	1/4"	95

2Way Manifold (Vertical Port Inlet)

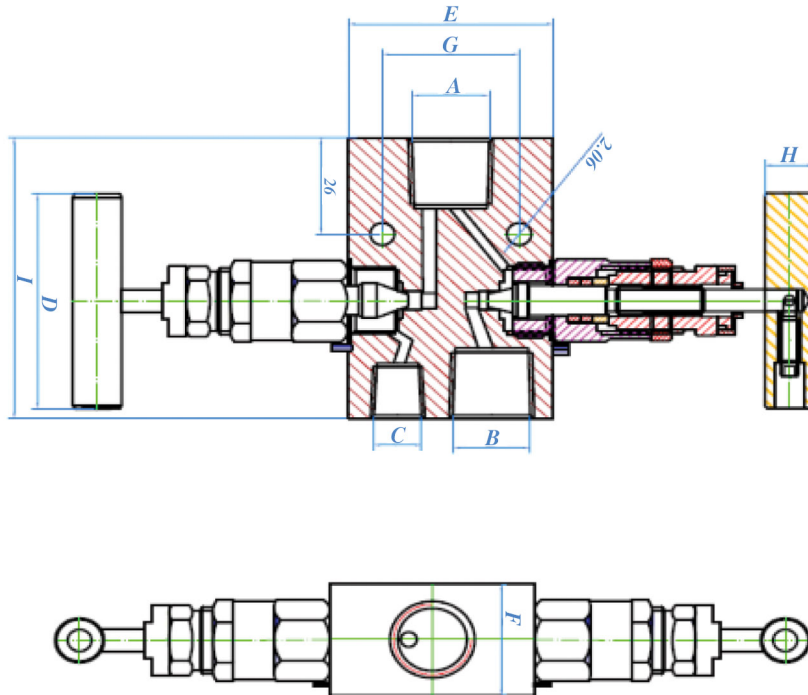

PAP Part Number	Working Pressure	End Connection		Dimensions							
		Inlet NPT(F)	Outlet NPT(F)	A NPT (F)	B NPT (F)	C NPT (F)	D(mm)	E(mm)	F(mm)	G(mm)	H
LS2V	3000 6000 10000 Psi	1/2"	1/2"	1/2"	1/2"	1/4"	58	50	32	33.5	Ø13

2Way Manifold for Panel Mounting

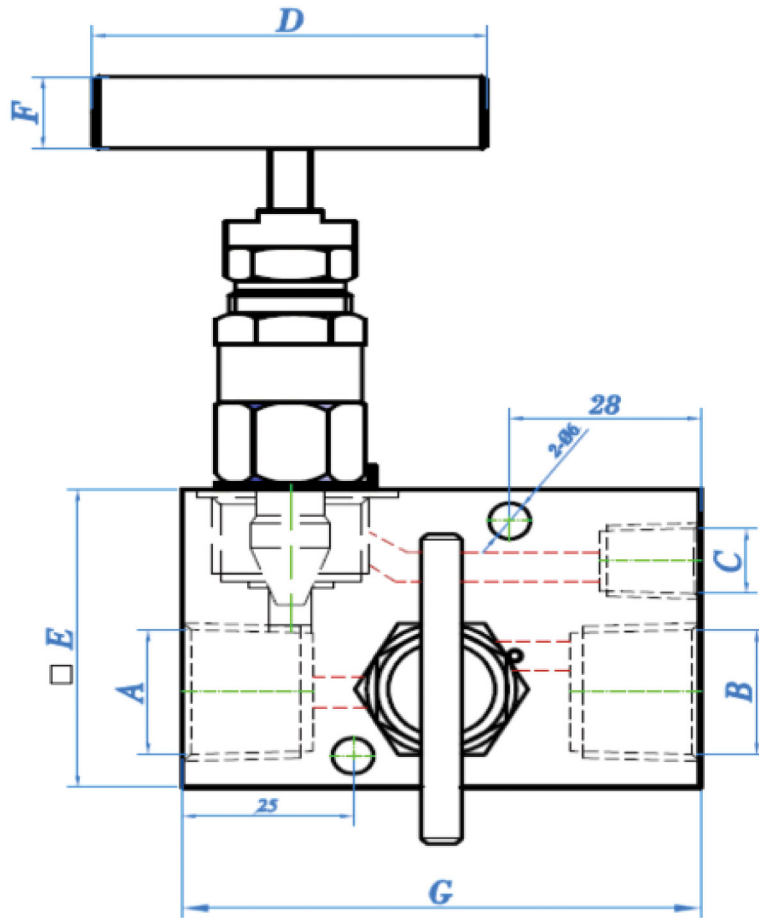

PAP Part Number	Working Pressure	End Connection			Dimensions						
		Inlet NPT(F)	Outlet NPT(F)	Drain /Test NPT(F)	A NPT (F)	B NPT (F)	C NPT (F)	D(mm)	E(mm)	F(mm)	G(mm)
LS2H	3000 6000 10000 Psi	1/2"	1/2"	1/4"	1/2"	1/2"	1/4"	58	50×32	Ø13	76

3Way Manifold NPT

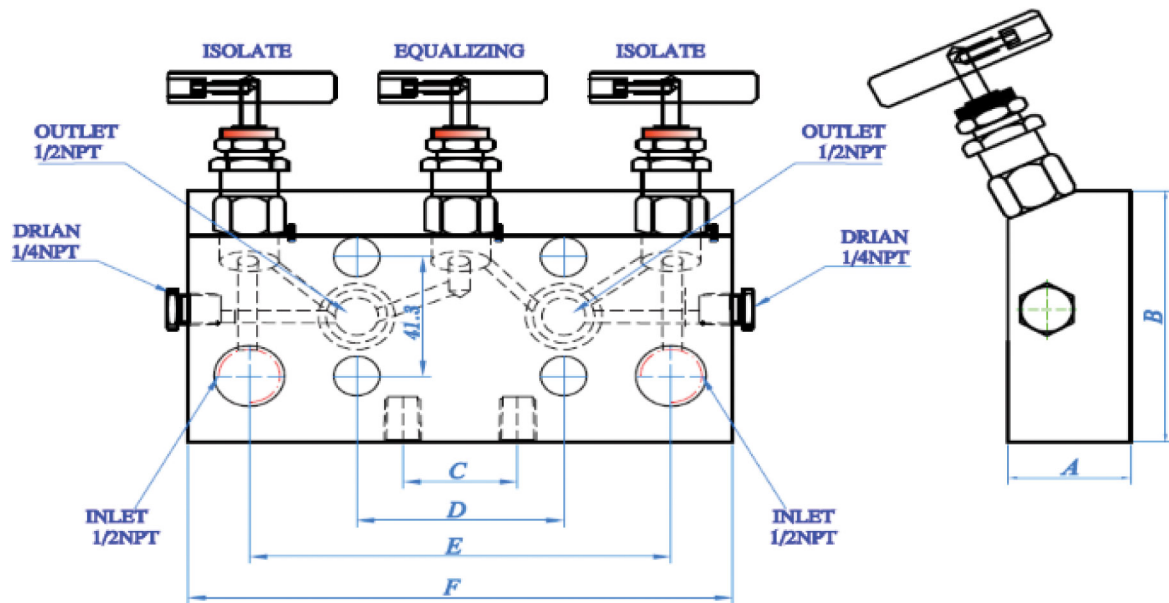

PAP Part Number	Working Pressure	End Connection		Dimensions					
		Inlet NPT(F)	Outlet NPT(F)	A(mm)	B(mm)	C(mm)	D(mm)	E(mm)	F(mm)
LS3	3000 6000 10000 Psi	1/2"	1/2"	32	76	30	54	110	142

3Way Manifold for Divert Mounting

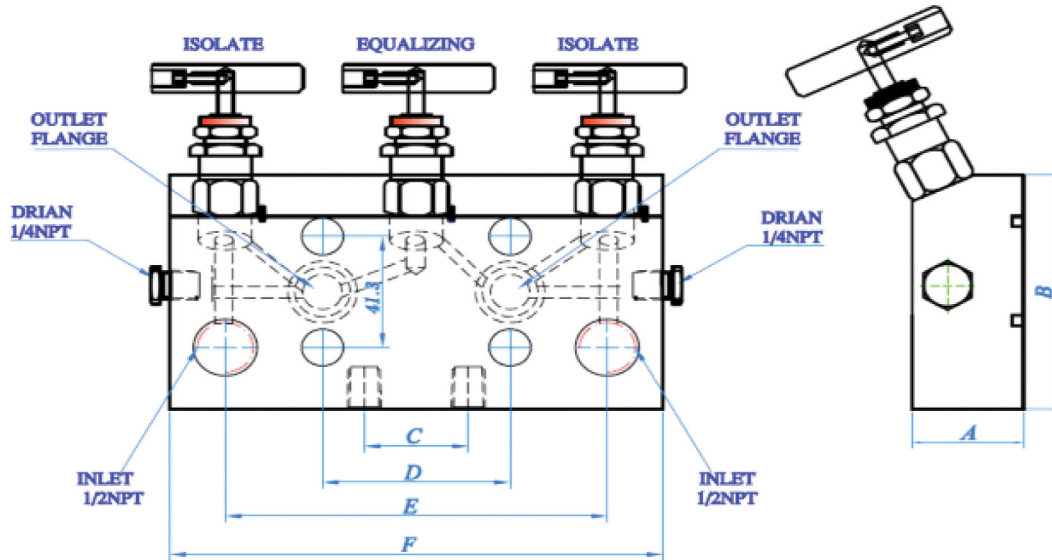

PAP Part Number	Working Pressure	End Connection		Dimensions					
		Inlet NPT(F)	Outlet NPT(F)	A(mm)	B(mm)	C(mm)	D(mm)	E(mm)	F(mm)
DS3	3000 6000 10000 Psi	1/2"	Flange	32	76	30	54	110	142

3Way Manifold for Line Remote Installation

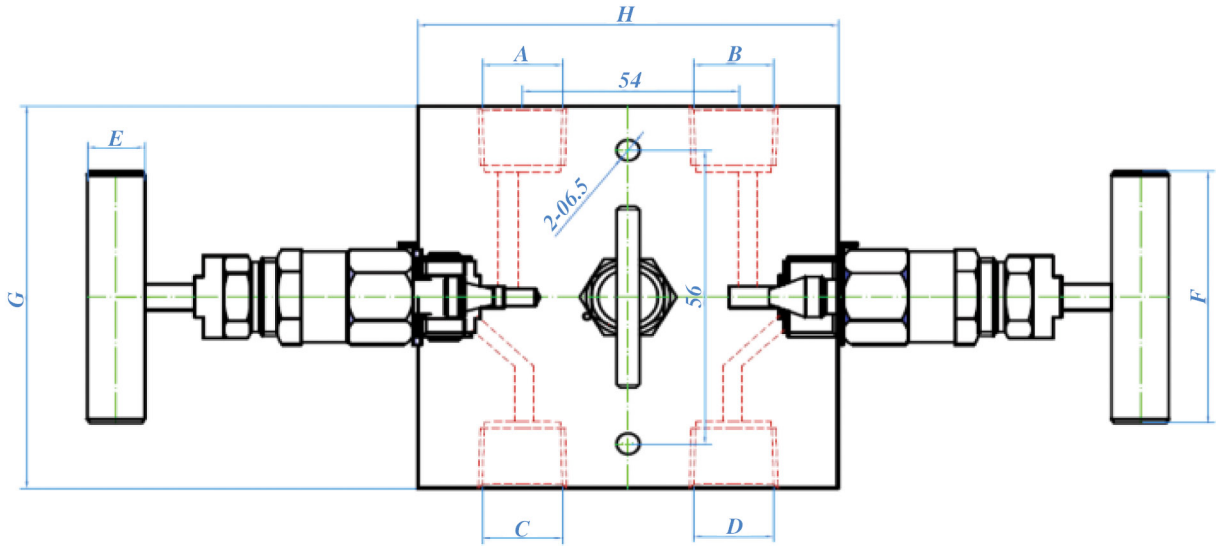

PAP Part Number	Working Pressure	End Connection		Dimensions							
		Inlet NPT(F)	Outlet NPT(F)	A NPT(F)	B NPT(F)	C NPT(F)	D NPT(F)	E	F(mm)	G(mm)	H(mm)
LS3H	3000 6000 10000 Psi	1/2"	1/2"	1/2"	1/2"	1/2"	1/2"	Ø13	58	76	86

5Way Manifold

NPT (Pipe Thread End Connections) & NPT (Pipe Flange End Connections) For Divert Mounting

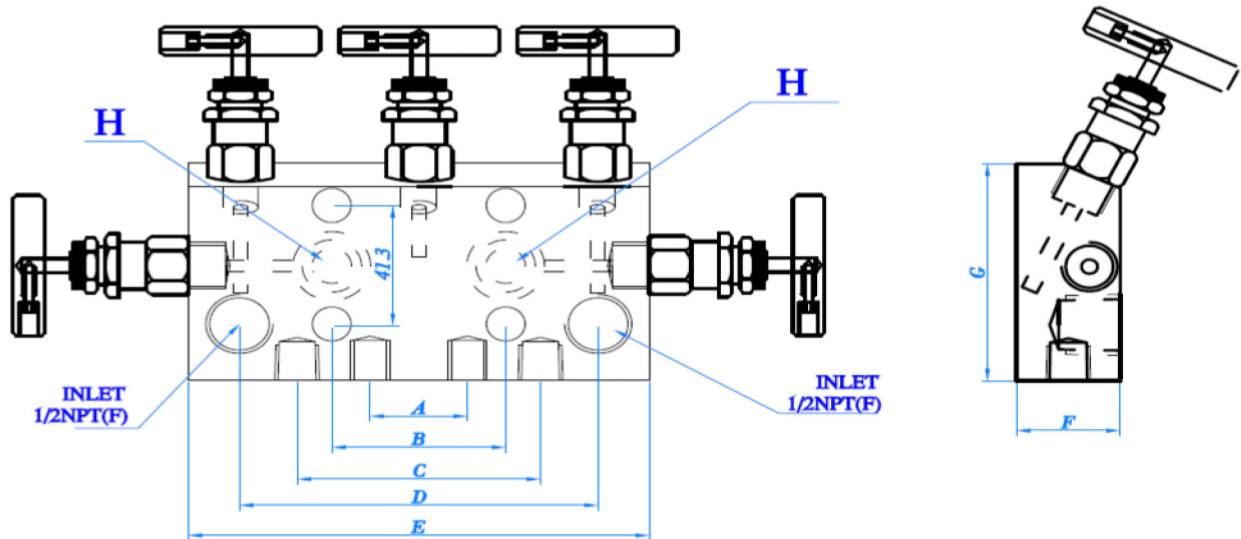

PAP Part Number	Working Pressure	End Connection		Dimensions							
		Inlet	Outlet	A (mm)	B (mm)	C (mm)	D (mm)	E (mm)	F (mm)	G (mm)	H
LS5	3000 6000	1/2" NPT(F)	1/2" NPT(F)	30	54	75	110	142	32	76	1/2" NPT(F)
DS5	10000 Psi	1/2"	Flange	30	54	75	110	142	32	76	1/2" Flange

5Way Manifold For Line Mounting

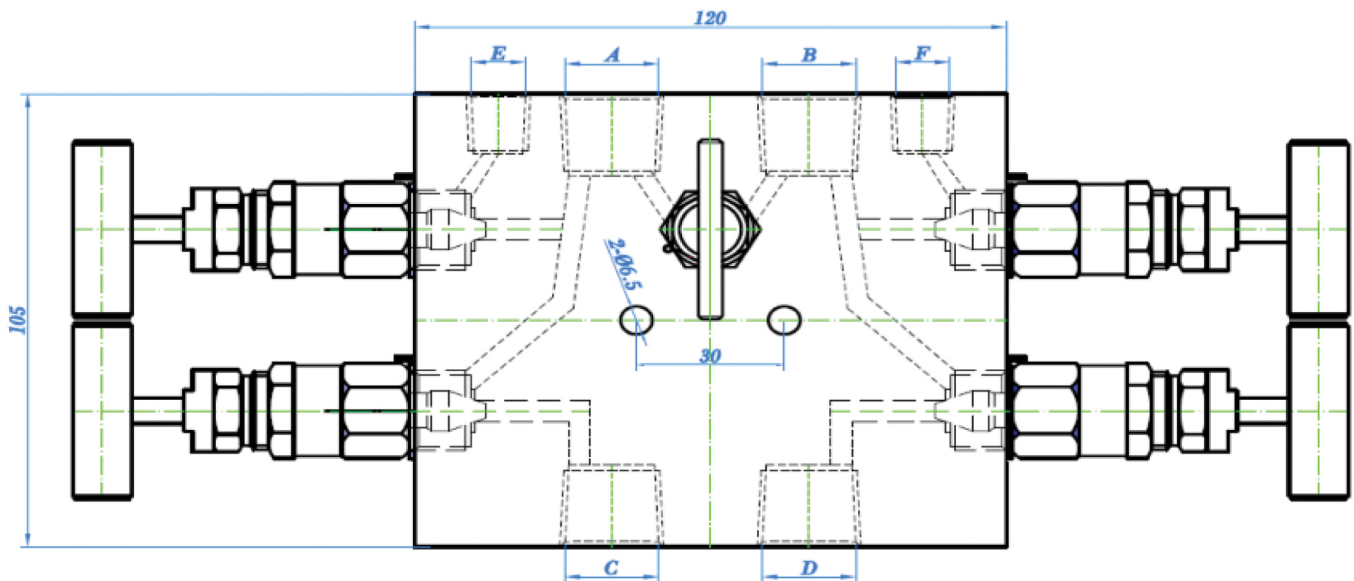

PAP Part Number	Working Pressure	End Connection		Dimensions					
		Inlet NPT(F)	Outlet NPT(F)	A NPT(F)	B NPT(F)	C NPT(F)	D NPT(F)	E NPT(F)	F NPT(F)
LS5H	3000 6000 10000 Psi	1/2"	1/2"	1/2"	1/2"	1/2"	1/2"	1/4"	1/4"

INSTRUMENT BALL VALVES

High Pressure Ball Valves (HPBV Series)

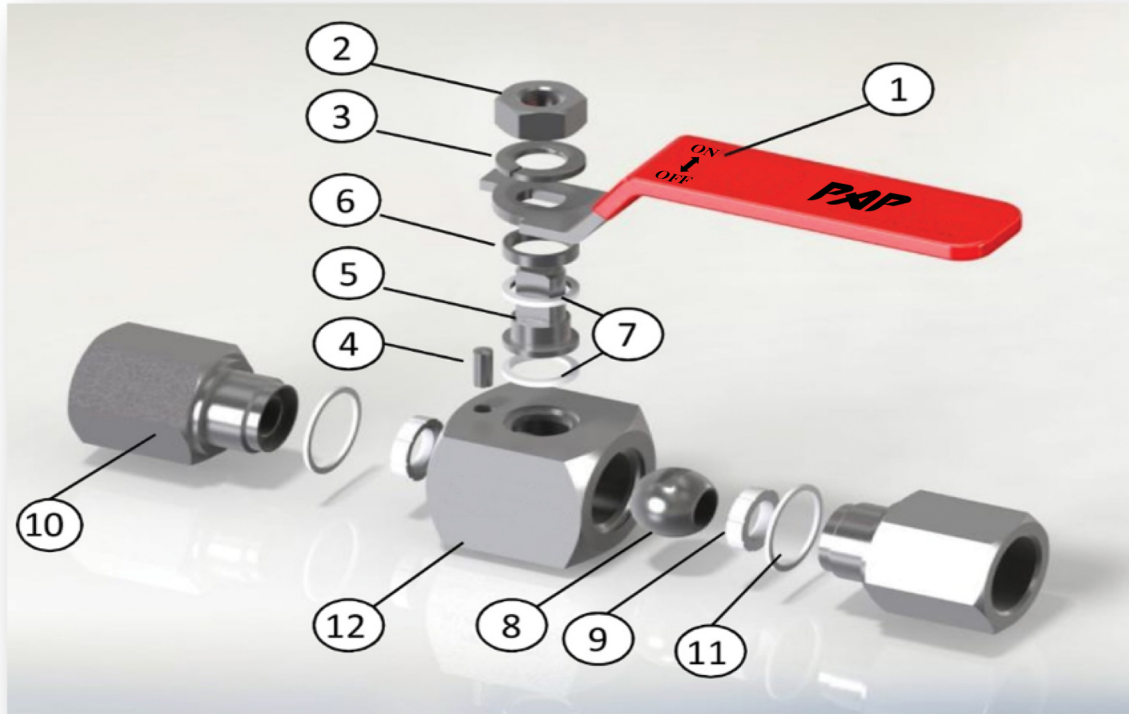

Materials of Construction		
Row	Component	Material Grade /ASTM SPECIFICATION
		Stainless Steel
1	Handle	Stainless Steel Lever Handle with PVC color Coated
2	Lock Nut	Stainless Steel
3	Spring Washer	Stainless Steel
4	Pin	Stainless Steel
5	Stem	SS316L
6	Stem Washer	SS316L
7	Stem Packing	PTFE
8	Ball	SS316/CF8M
9	Seat	PTFE(Standard)
10	End Connector	SS316L
11	Connector Seal	PTFE
12	Body	SS316L

Ball Valve, HPBV SERIES

NPT F.F (FEMALE PIPE THREAD END CONNECTIONS)

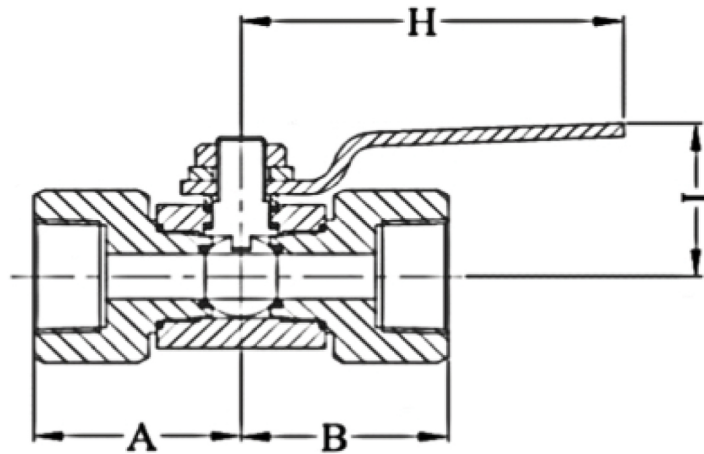

PAP Part Number	Working Pressure	End Connection	Dimensions (mm)			
			A	B	I	H
BA1NN3M004	3000Psi	1/4 Female NPT	46	46	43	105
BA1NN3M006		3/8 Female NPT	46	46	43	105
BA1NN3M008		1/2 Female NPT	46	46	43	105
BA1NN3M012		3/4 Female NPT	46	46	43	105
BA1NN3M016		1 Female NPT	59	59	54	155
BA1NN6M004	6000Psi	1/4 Female NPT	46	46	43	105
BA1NN6M006		3/8 Female NPT	46	46	43	105
BA1NN6M008		1/2 Female NPT	46	46	43	105
BA1NN6M012		3/4 Female NPT	59	59	54	155
BA1NN6M016		1 Female NPT	59	59	54	155

BALL VALVE, HPBV SERIES

NPT F.M (FEMALE& MALE PIPE THREAD END CONNECTIONS)

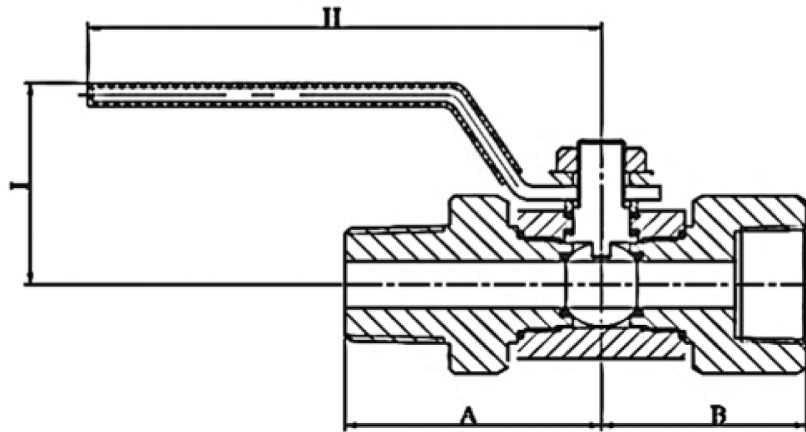

PAP Part Number	Working Pressure	End Connection	Dimensions (mm)			
			A	B	I	H
BA1NM3M004	3000Psi	1/4 Female*Male NPT	46	46	42	105
BA1NM3M006		3/8 Female*Male NPT	46	48	42	105
BA1NM3M008		1/2 Female*Male NPT	46	48	42	105
BA1NM3M012		3/4 Female*Male NPT	48	48	42	105
BA1NM3M016		1 Female*Male NPT	59	59	54	155
BA1NM6M004*	6000Psi	1/4 Female*Male NPT	46	46	43	105
BA1NM6M006*		3/8 Female*Male NPT	46	46	43	105
BA1NM6M008*		1/2 Female*Male NPT	46	46	43	105
BA1NM6M012*		3/4 Female*Male NPT	59	59	54	155
BA1NM6M016*		1 Female*Male NPT	59	59	54	155

**BALL VALVE, HPBV SERIES
SW (SOCKET WELD END CONNECTIONS)**

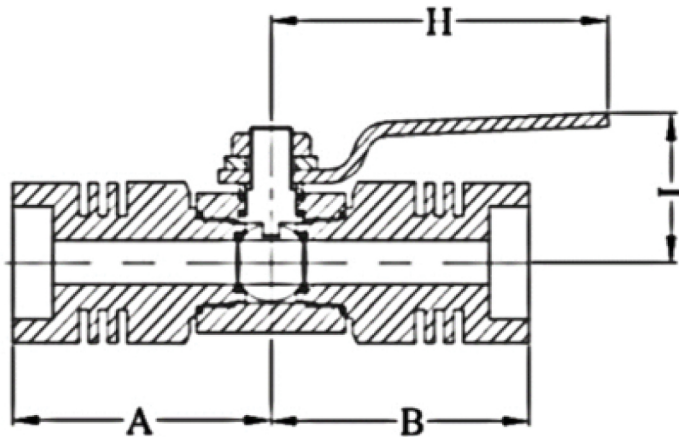

PAP Part Number	Working Pressure	End Connection	Dimensions (mm)			
			A	B	I	H
BA1CC3M004	3000Psi	1/4 Socket Weld	62	62	43	105
BA1CC3M006		3/8 Socket Weld	62	62	43	105
BA1CC3M008		1/2 Socket Weld	62	62	43	105
BA1CC3M012		3/4 Socket Weld	62	62	43	105
BA1CC3M016		1 Socket Weld	79	79	54	155
BA1CC6M004	6000Psi	1/4 Socket Weld	62	62	43	105
BA1CC6M006		3/8 Socket Weld	62	62	43	105
BA1CC6M008		1/2 Socket Weld	62	62	43	105
BA1CC6M012		3/4 Socket Weld	79	79	54	155
BA1CC6M016		1 Socket Weld	79	79	54	155

BALL VALVE, HPBV SERIES

O.D (TUBE END CONNECTIONS)

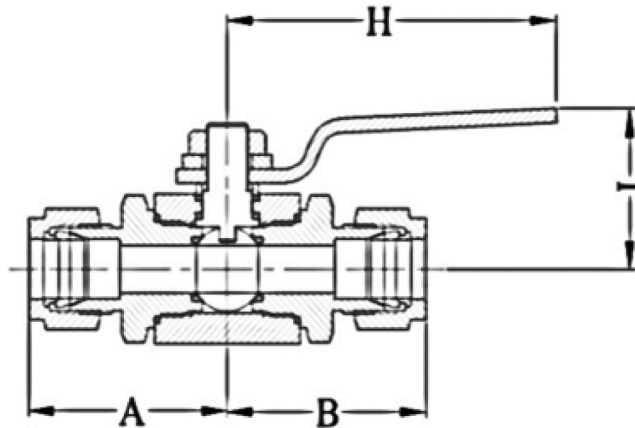

PAP Part Number	Working Pressure	End Connection	Dimensions (mm)			
			A	B	I	H
BA1003M004	3000Psi	1/4 O.D	43	43	43	105
BA1003M006		3/8 O.D	45	45	43	105
BA1003M008		1/2 O.D	48	48	43	105
BA1003M012		3/4 O.D	50	50	43	105
BA1003M016		1 O.D	55	55	54	155
BA1003M096		6 O.D	43	43	43	105
BA1003M128		8 O.D	45	45	43	105
BA1003M160		10 O.D	48	48	43	105
BA1003M192		12 O.D	50	50	43	105
BA1006M004	6000Psi	1/4 O.D	43	43	43	105
BA1006M006		3/8 O.D	45	45	43	105
BA1006M008		1/2 O.D	48	48	43	105
BA1006M012		3/4 O.D	50	50	54	155
BA1006M016		1 O.D	55	55	54	155
BA1006M096		6 O.D	43	43	43	105
BA1006M128		8 O.D	45	45	43	105
BA1006M160		10 O.D	48	48	43	105
BA1006M192		12 O.D	50	50	54	155

Block and Bleed Valves Coding:

Example-1): PAP -DB-D11 - F 8 R1 N 8 - P -SS
 1 3 4 5 3 4 6 7

Example-2): PAP -DB-D11 - FB - F 8 R3- P -SS
 1 2 3 4 5 6 7

1. Valve Series

SERIES IDENTIFY				1ts ISOLATE	2ts ISOLATE	VENT
SB	SINGLE BLOCK & BLEED VALVES	S1	1	BALL	-	NEEDLE
		S1	2	BALL	-	OS & Y
		S1	3	BALL	-	BALL
		S2	1	OS & Y	-	OS & Y
		S2	2	OS & Y	-	NEEDLE
		S2	3	NEEDLE	-	NEEDLE
DB	DOUBLE BLOCK & BLEED VALVES	D1	1	BALL	BALL	NEEDLE
		D1	2	BALL	BALL	OS & Y
		D1	3	BALL	BALL	BALL
		D1	4	BALL	NEEDLE	NEEDLE
		D1	5	BALL	BALL	-
		D1	6	BALL	NEEDLE	-
		D2	1	OS & Y	OS & Y	OS & Y
		D2	2	OS & Y	OS & Y	NEEDLE
		D2	3	OS & Y	NEEDLE	NEEDLE
		D2	4	NEEDLE	NEEDLE	NEEDLE

2. Bore size (mm)
 (STD) - 10mm (standard)
 15- 15mm
 RB- Reducer Bore
 FB- Full Bore

3. Connection type
 F- RAISED FACE FLANGE
 J- RING JOINT FLANGE
 N- FEMALE NPT
 M- MALE NPT
 FF- FLAT FACE FLANGE
 BW- BUTT WELD
 SW- SOCKET WELD

4. Connection size(inch)
 4- 1/4" 16- 1"
 6- 3/8" 24- 1 1/2"
 8- 1/2" 32- 2"
 12- 3/4"

5. Flange rating (class)
 R1- 150 R4- 900
 R2- 300 R5- 1500
 R3- 600 R6- 2500

6. Ball seat material
 RP- R. PTFE
 P- PTFE

7. Body material
 SS- ASTM A182 GR 316L
 105- ASTM A105
 LF2- ASTM A350 LF2

- Reduced or full port
- Construction: B.B, OS & Y
- Socket Welding & Threaded ends
- Material for hard trim is Depend on Client notice & Operating Condition

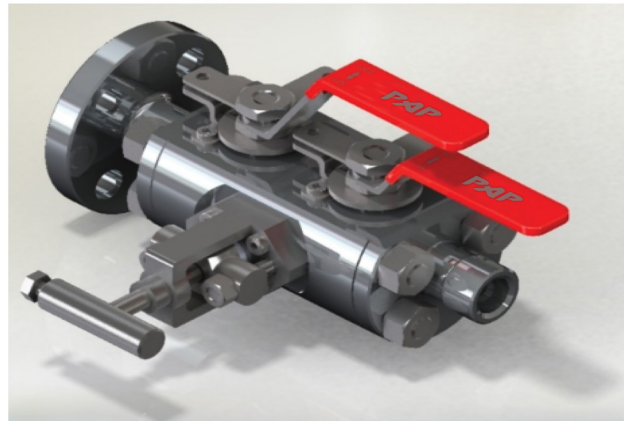

Materials of Construction

Row	PART NAME	Row	PART NAME
1	Body	14	Seat
2	Stop Pin	15	Thrust Washer
3	Steam O-Ring	16	Stem Nut
4	Ring	18	Stem Gasket
5	Stem	19	Bonnet O-ring
7	Indicator	20	Body Gasket
8	Closure	21	Name Plate
9	Wrench	22	Pin
10	Body Nut	23	Hex Plug 1/4 NPT
11	Body Stud Bolt	24	Needle Valve (Type 3)
12	Spring	27	Locking Device
13	Ball		

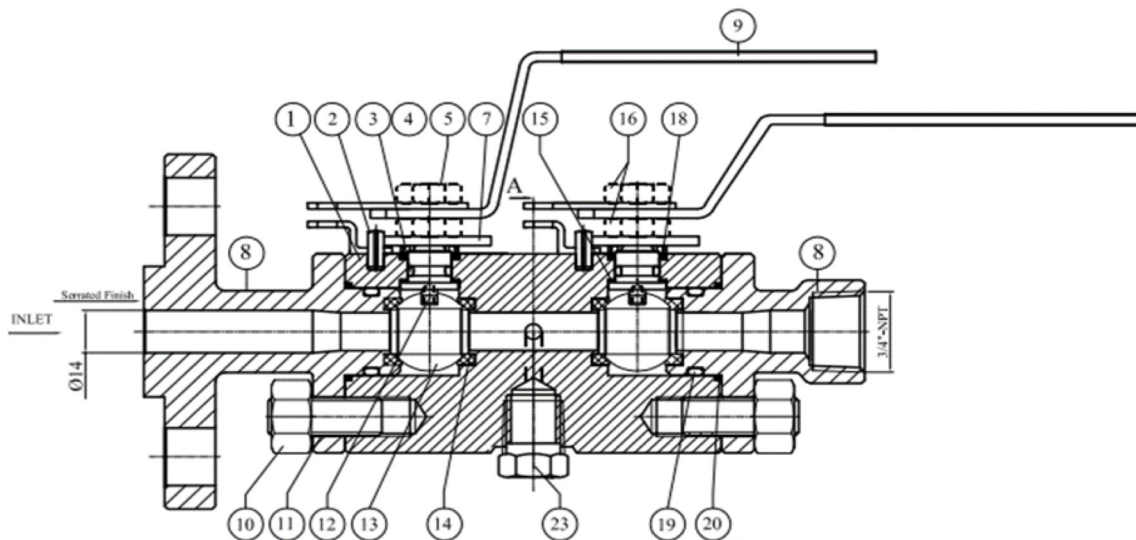
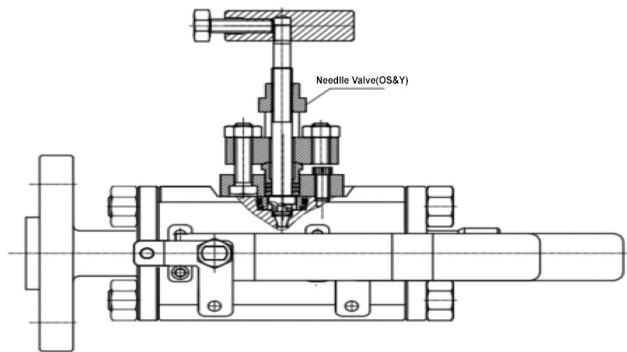
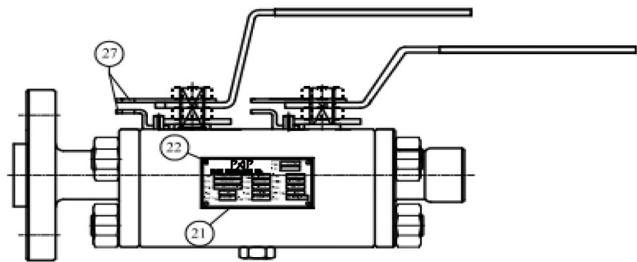

- Reduced or full port
- Construction: B.B, OS & Y
- Socket Welding & Threaded ends
- Material for hard trim is Depend on Client notice & Operating Condition

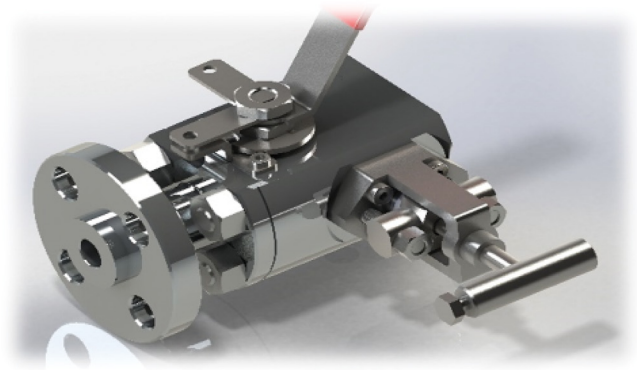

Materials of Construction

Row	PART NAME	Row	PART NAME
1	Body	14	Seat
2	Stop Pin	15	Thrust Washer
3	Steam O-Ring	16	Stem Nut
4	Ring	18	Stem Gasket
5	Stem	19	Bonnet O-ring
7	Indicator	20	Body Gasket
8	Closure	21	Name Plate
9	Wrench	22	Pin
10	Body Nut	23	Hex Plug 1/4 NPT
11	Body Stud Bolt	24	Needle Valve (Type 3)
12	Spring	27	Locking Device
13	Ball		

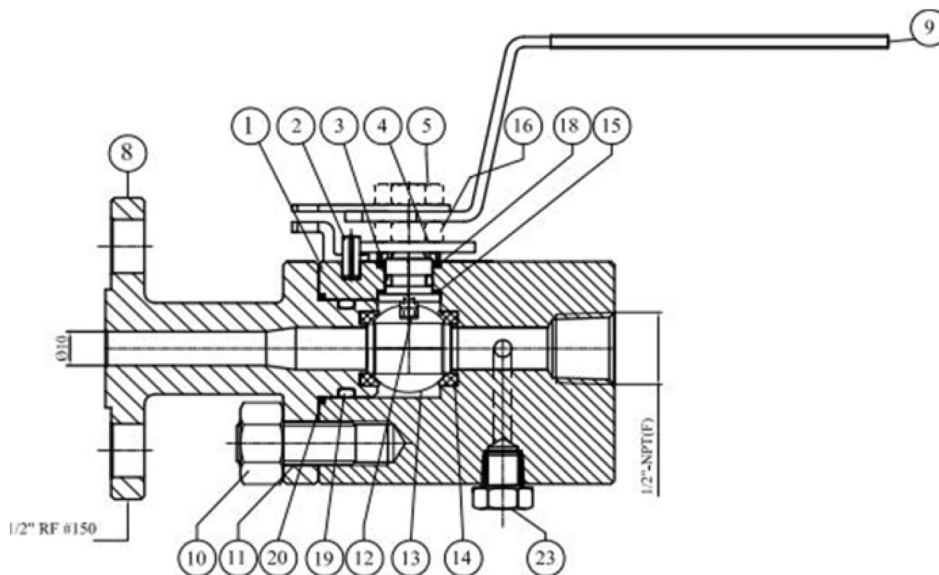
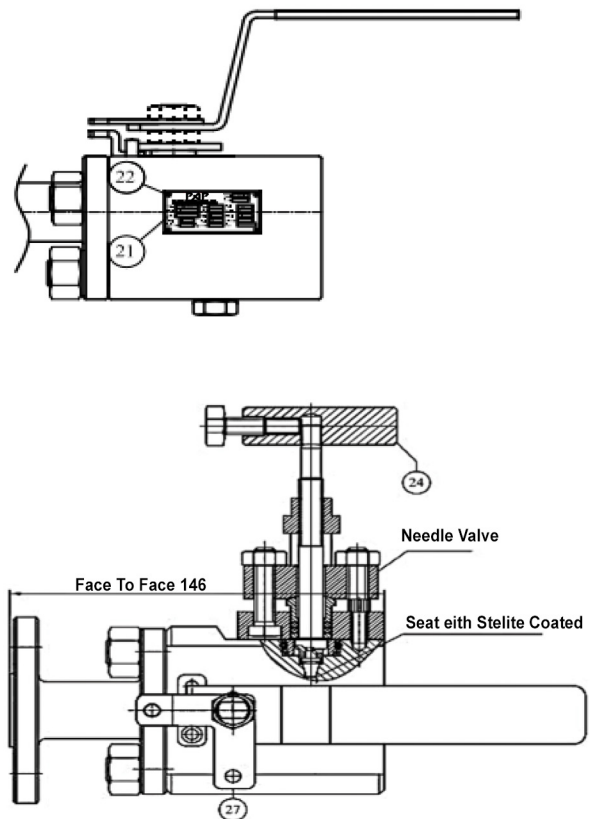

- ASME B 16.5
- FACE CONDITION 125-250 AARH
- WRENCH OPERATION
- BALL ARRANGEMENT: FLOATING
- ANTI-BLOWOUT BECAUSE OF BODY AND STEM CONDITION

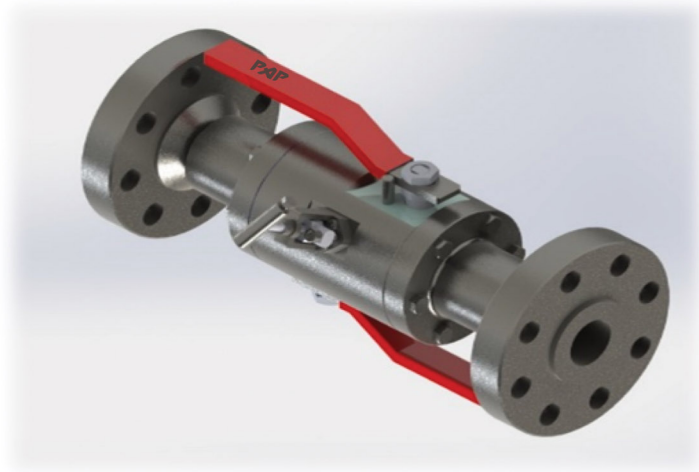

Bill of Material		
1	BODY	A105N
2	BALL	S.S 316
3	SEAT	PTFE
4	THRUST BEARING	PTFE
5	STEM PACKING	PTFE
6	STEM	S.S 316L
7	NUT	S.S 304
8	HANDEL (STOPPER)	C.S
9	GLAND	S.S 316L
10	O-RING	VITON
11	BODY SEAL	PTFE
12	BONNET	A105N
13	BOLT/NUT	A194-GR2HM/A193 GR.B7M
14	OS & Y	SEAT:17-4PH BONNET: A182 F316L SEAL: PTFE
15	PLUG	A105L
16	FLANGE	A105L
17	STOP PIN	S.S 316L
18	LOCKING DEVICE	S.S
19	RETAINER SEAL	PTFE
20	SEAT RETAINER	S.S 316L

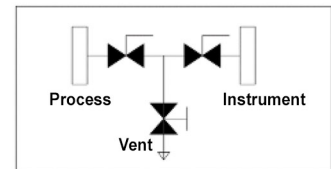
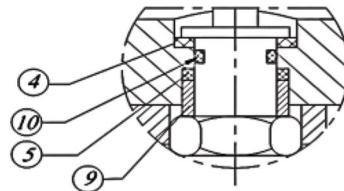
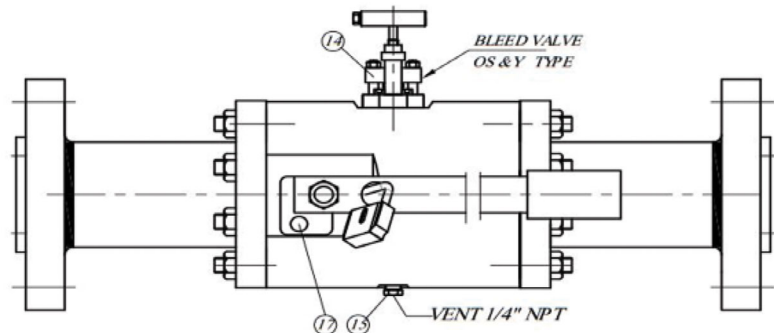
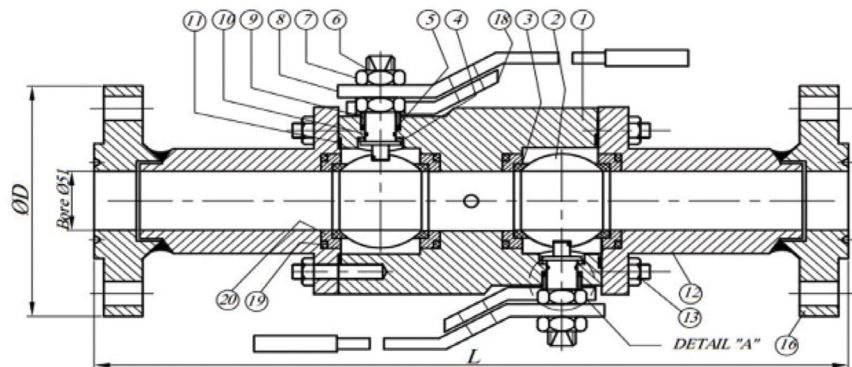
Detail A

FORGED GATE VALVES

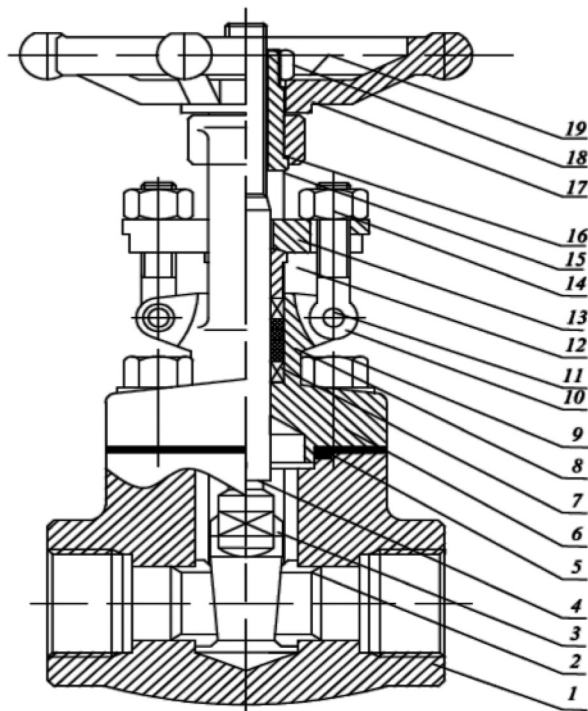

No.	Component	Material / ASTM SPECIFICATION
1	Body	A105N
2	SEAT RING	ASTM A276-420
3	WEDGE	ASTM A182-F6a
4	STEM	ASTM A276-410
5	GASKET	S.S 304+Graphite
6	BONNET	A105N
7	PACKING	Fiber
8	BONNET BOLT	Graphite
9		ASTM A193-B7M
10	GLAND BOLT (EYE BOLT)	ASTM A193-B7M
11	GLAND BOLT PIN	S.S 304 (ISO 8740)
12	GLAND	ASTM A276-410
13	GLAND FLANGE	A105N
14	GLAND NUT	ASTM A194-2HM
15	YOKE SLEEVE	CR.13
16	SLEEVE WASHER	AISI 1025
17	HANDWHEEL	Malleable Iron
18	H/W NUT	AISI 1025+Cr. Plated
19	NAMEPLATE	S.S 304

GATE VALVE

NPT (PIPE THREAD END CONNECTIONS)

SW (SOCKET WELD END CONNECTIONS)

W.B (Welded Bonet)

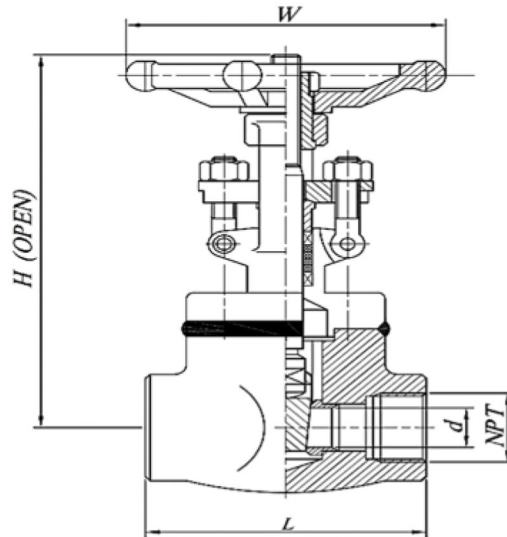

Features and Applications

- Reduced or full port
- Construction: W.B (OS & Y)
- Gasket: Stainless Steel + graphite
- Socket Welding & Threaded ends
- Material for hard trim is Depend on Client notice & Operating condition
- Design & manufacture: API 602 & ANSI B 16.34
- Socket welding dimension: ANSI B 16.11
- Screw end dimension: ANSI B1.20.1
- Inspect and test: API 598
- Body material: A105, LF2, F5, F11, F22, F304L, F316L
- All dimensions could be considered as reference

PAP Part Number		CLASS	Size		Size				Weight	
NPT	SW		Reducer Bore	Full Bore	d	L	H(Open)	W	W.W	W.W
				mm	mm	mm	mm	Kg		
GAWNN4C	GAWCC4C	800	1/4"	-	7	79	166	100	2.5	-
GAWNN4C	GAWCC4C		3/8"	-	7	79	166	100	2.4	-
GAWNN4C	GAWCC4C		1/2"	3/8"	10	79	166	100	2.3	2.4
GAWNN4C	GAWCC4C		3/4"	1/2"	12.7	92	169	100	2.6	2.7
GAWNN4C	GAWCC4C		1"	3/4"	18	111	193	125	4.5	4.6
GAWNN4C	GAWCC4C		1 1/4"	1"	23	120	230	160	5.9	6.1
GAWNN4C	GAWCC4C		1 1/2"	1 1/4"	28.5	120	246	160	7.2	7.4
GAWNN4C	GAWCC4C		2"	1 1/2"	36	140	283	180	11.2	11.4
GAWNN4C	GAWCC4C		-	2"	43	170	332	200	18.8	19.1

GATE VALVE

NPT (PIPE THREAD END CONNECTIONS)

SW (SOCKET WELD END CONNECTIONS)

B.B (Bolted Bonet)

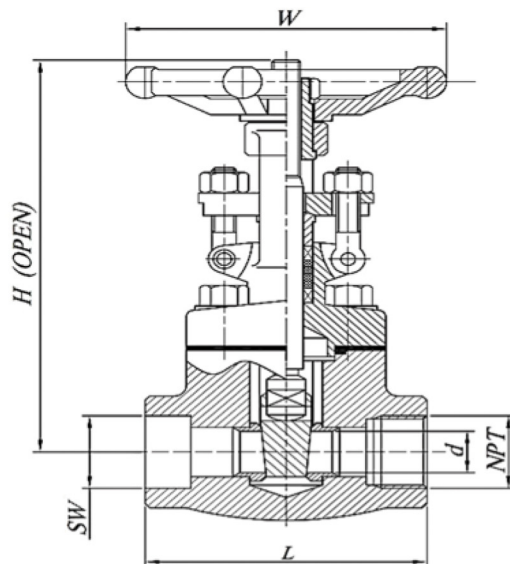

Features and Applications

- Reduced or full port
- Construction: B.B (OS & Y)
- Gasket: Stainless Steel + graphite
- Socket Welding & Threaded ends
- Material for hard trim is Depend on Client notice & Operating condition
- Design & manufacture: API 602 & ANSI B 16.34
- Socket welding dimension: ANSI B 16.11
- Screw end dimension: ANSI B1.20.1
- Inspect and test: API 598
- Body material: A105, LF2, F5, F11, F22, F304L, F316L
- All dimensions could be considered as reference.

PAP Part Number		CLASS	Size		Size				Weight	
NPT	SW		Reducer Bore	Full Bore	d	L	H(Open)	W	W.B	B.B
				mm	mm	mm	mm	Kg		
GABNN4C	GABCC4C	800	1/4"	-	7	79	166	100	2.5	-
GABNN4C	GABCC4C		3/8"	-	7	79	166	100	2.4	-
GABNN4C	GABCC4C		1/2"	3/8"	10	79	166	100	2.3	2.4
GABNN4C	GABCC4C		3/4"	1/2"	12.7	92	169	100	2.6	2.7
GABNN4C	GABCC4C		1"	3/4"	18	111	193	125	4.5	4.6
GABNN4C	GABCC4C		1 1/4"	1"	23	120	230	160	5.9	6.1
GABNN4C	GABCC4C		1 1/2"	1 1/4"	28.5	120	246	160	7.2	7.4
GABNN4C	GABCC4C		2"	1 1/2"	36	140	283	180	11.2	11.4
GABNN4C	GABCC4C		-	2"	43	170	332	200	18.8	19.1

GATE VALVE

NPT (PIPE THREAD END CONNECTIONS)

SW (SOCKET WELD END CONNECTIONS)

W.B (Welded Bonet)

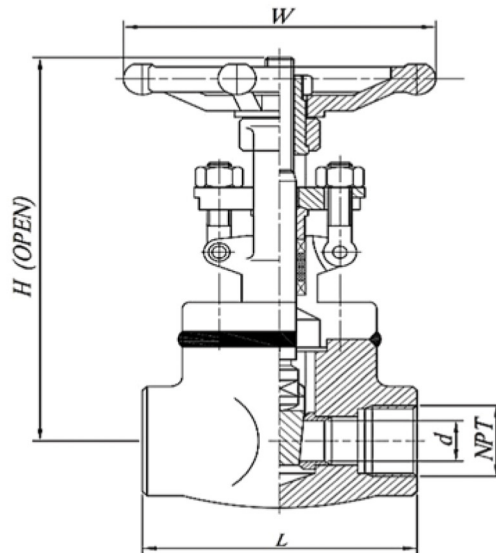

Features and Applications

- Reduced or full port
- Construction: W.B(OS & Y)
- Gasket: Stainless Steel + graphite
- Socket Welding & Threaded ends
- Material for hard trim is Depend on Client notice & Operating condition
- Design & manufacture: API 602 & ANSI B 16.34
- Socket welding dimension: ANSI B 16.11
- Screw end dimension: ANSI B1.20.1
- Inspect and test: API 598
- Body material: A105, LF2, F5, F11, F22, F304L, F316L
- All dimensions could be considered as reference.

PAP Part Number		CLASS	Nominal Diameter	Size				Weight	
NPT	SW			d	L	H(Open)	W	B,B	W.B
				mm	mm	mm	mm	Kg	
GAWNN5C	GAWCC5C	1500	3/8"	10	79	170	100	4.7	4.8
GAWNN5C	GAWCC5C		1/2"	12.7	92	193	100	4.7	4.8
GAWNN5C	GAWCC5C		3/4"	18	111	230	100	6.8	6.9
GAWNN5C	GAWCC5C		1"	23	120	246	125	9.0	9.2
GAWNN5C	GAWCC5C		1 1/4"	28.5	120	283	160	12.4	12.6
GAWNN5C	GAWCC5C		1 1/2"	36	140	325	160	17.5	17.7
GAWNN5C	GAWCC5C		2"	43	170	334	180	18.0	17.9

GATE VALVE

NPT (PIPE THREAD END CONNECTIONS)

SW (SOCKET WELD END CONNECTIONS)

B.B (Bolted Bonet)

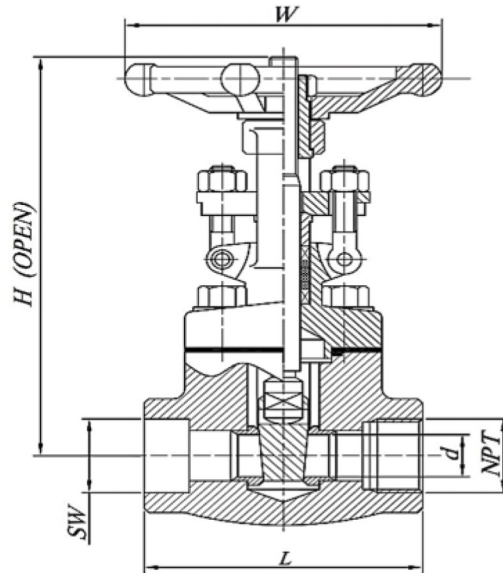

Features and Applications

- Reduced or full port
- Construction: B.B (OS & Y)
- Gasket: Stainless Steel + graphite
- Socket Welding & Threaded ends
- Material for hard trim is Depend on Client notice & Operating condition
- Design & manufacture: API 602 & ANSI B 16.34
- Socket welding dimension: ANSI B 16.11
- Screw end dimension: ANSI B1.20.1
- Inspect and test: API 598
- Body material: A105, LF2, F5, F11, F22, F304L, F316L
- All dimensions could be considered as reference.

PAP Part Number		CLASS	Nominal Diameter	Size				Weight	
				d	L	H(Open)	W	B,B	W.B
NPT	SW		mm	mm	mm	mm	Kg		
GABNN5C	GABCC5C	1500	3/8"	10	79	170	100	4.7	4.8
GABNN5C	GABCC5C		1/2"	12.7	92	193	100	4.7	4.8
GABNN5C	GABCC5C		3/4"	18	111	230	100	6.8	6.9
GABNN5C	GABCC5C		1"	23	120	246	125	9.0	9.2
GABNN5C	GABCC5C		1 1/4"	28.5	120	283	160	12.4	12.6
GABNN5C	GABCC5C		1 1/2"	36	140	325	160	17.5	17.7
GABNN5C	GABCC5C		2"	43	170	334	180	18.0	17.9

FORGED GLOBE VALVES

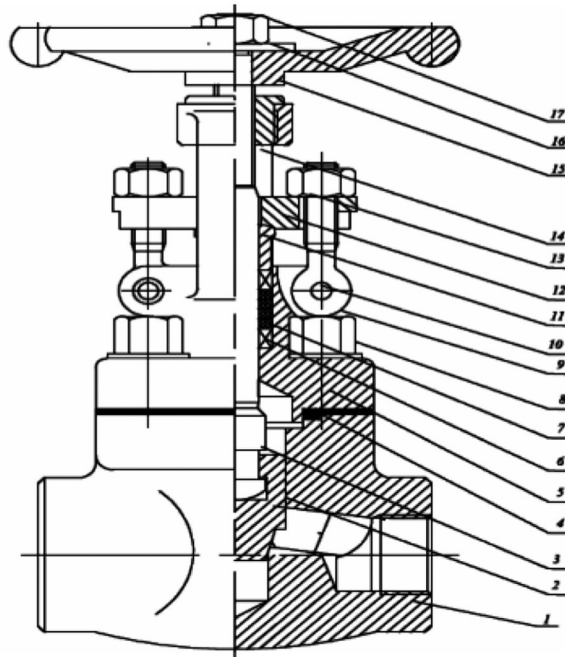

No.	Component	Material/ASTM SPECIFICATION
1	Body	A105N
2	SEAT RING	ASTM A276-420
3	WEDGE	ASTM A182-F6A
4	STEM	ASTM A276-410
5	GASKET	S.S 304+Graphite
6	BONNET	A105N
7	PACKING	Fiber
8	BONNET BOLT	Graphite
9		ASTM A193-B7M
10	GLAND BOLT (EYE BOLT)	ASTM A193-B7M
11	GLAND BOLT PIN	S.S 304 (ISO 8740)
12	GLAND	ASTM A276-410
13	GLAND FLANGE	A105N
14	GLAND NUT	ASTM A194-2HM
15	YOKE SLEEVE	CR.13
16	SLEEVE WASHER	AISI 1025
17	HANDWHEEL	Malleable Iron
18	H/W NUT	AISI 1025+Cr. Plated
19	NAMEPLATE	S.S 304

GLOBE VALVE

NPT (PIPE THREAD END CONNECTIONS)

SW (SOCKET WELD END CONNECTIONS)

W.B (Welded Bonet)

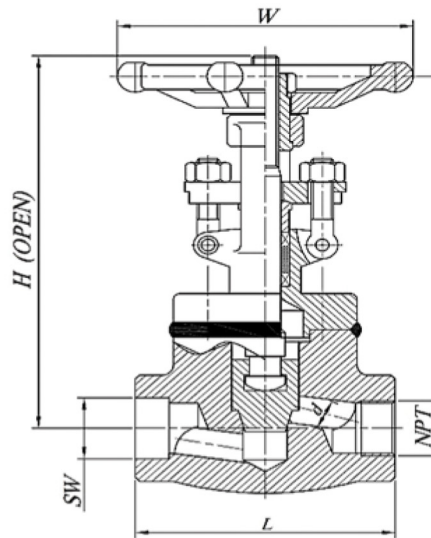

Features and Applications

- Reduced or full port
- Construction: W.B (OS & Y)
- Gasket: Stainless Steel + graphite
- Socket Welding & Threaded ends
- Integral Seat
- Design & manufacture: API 602 & ANSI B 16.34
- Socket welding dimension: ANSI B 16.11
- Screw end dimension: ANSI B1.20.1 (NPT)
- Inspect and test: API 598
- Body material: A105, LF2, F5, F11, F22, F304L, F316L
- All dimensions could be considered as reference.

PAP Part Number		CLASS	Size		Size				Weight	
NPT	SW		Reducer Bore	Full Bore	d	L	H(Open)	W	B.B	W.B
					mm	mm	mm	mm	Kg	
GOWNN4C	GOWCC4C	800	1/4"	-	8	79	166	100	2.6	-
GOWNN4C	GOWCC4C		3/8"	-	10	79	166	100	2.5	-
GOWNN4C	GOWCC4C		1/2"	3/8"	11	79	166	100	2.4	2.5
GOWNN4C	GOWCC4C		3/4"	1/2"	13	92	175	100	2.6	2.7
GOWNN4C	GOWCC4C		1"	3/4"	18	111	206	125	4.5	4.7
GOWNN4C	GOWCC4C		1 1/4"	1"	23	120	228	160	5.9	6.1
GOWNN4C	GOWCC4C		1 1/2"	1 1/4"	28.5	152	262	160	8.3	8.5
GOWNN4C	GOWCC4C		2"	1 1/2"	33	172	300	180	12.4	12.6
GOWNN4C	GOWCC4C		-	2"	43	220	340	240	20	20.4

GLOBE VALVE

NPT (PIPE THREAD END CONNECTIONS)

SW (SOCKET WELD END CONNECTIONS)

B.B (Bolted Bonet)

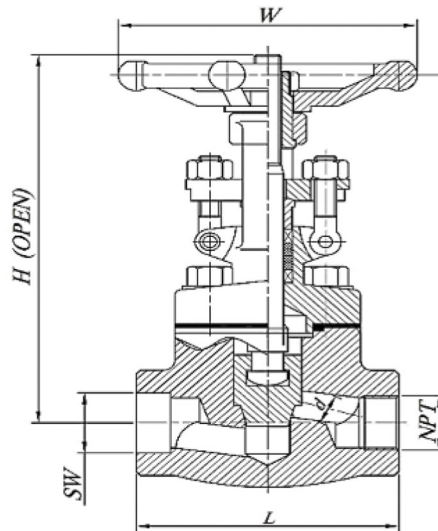

Features and Applications

- Reduced or full port
- Construction: B.B (OS & Y)
- Gasket: Stainless Steel + graphite
- Socket Welding & Threaded ends
- Integral Seat
- Design & manufacture: API 602 & ANSI B 16.34
- Socket welding dimension: ANSI B 16.11
- Screw end dimension: ANSI B1.20.1 (NPT)
- Inspect and test: API 598
- Body material: A105, LF2, F5, F11, F22, F304L, F316L
- All dimensions could be considered as reference

PAP Part Number		CLASS	Size		Size				Weight	
NPT	SW		Reducer Bore	Full Bore	d	L	H(Open)	W	B.B	W.B
				mm	mm	mm	mm	Kg		
GOBNN4C	GOBCC4C	800	1/4"	-	8	79	166	100	2.6	-
GOBNN4C	GOBCC4C		3/8"	-	10	79	166	100	2.5	-
GOBNN4C	GOBCC4C		1/2"	3/8"	11	79	166	100	2.4	2.5
GOBNN4C	GOBCC4C		3/4"	1/2"	13	92	175	100	2.6	2.7
GOBNN4C	GOBCC4C		1"	3/4"	18	111	206	125	4.5	4.7
GOBNN4C	GOBCC4C		1 1/4"	1"	23	120	228	160	5.9	6.1
GOBNN4C	GOBCC4C		1 1/2"	1 1/4"	28.5	152	262	160	8.3	8.5
GOBNN4C	GOBCC4C		2"	1 1/2"	33	172	300	180	12.4	12.6
GOBNN4C	GOBCC4C		-	2"	43	220	340	240	20	20.4

GLOBE VALVE

NPT (PIPE THREAD END CONNECTIONS)

SW (SOCKET WELD END CONNECTIONS)

W.B (Welded Bonet)

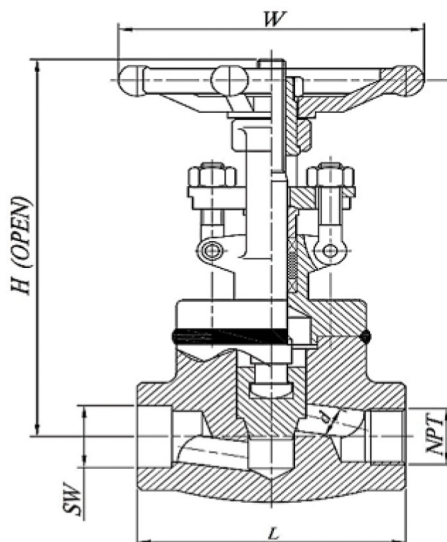

Features and Applications

- Construction: W.B(OS & Y)
- Gasket: Stainless Steel + graphite
- Socket Welding & Threaded ends
- Integral Seat
- Design & manufacture: API 602 & ANSI B 16.34
- Socket welding dimension: ANSI B 16.11
- Screw end dimension: ANSI B1.20.1 (NPT)
- Inspect and test: API 598
- Body material: A105, LF2, F5, F11, F22, F304L, F316L
- All dimensions could be considered as reference.

PAP Part Number		CLASS	Nominal Diameter	Size				Weight	
NPT	SW			d	L	H(Open)	W	B,B	W.B
				mm	mm	mm	mm	Kg	
GOWNN5C	GOWCC5C	1500	3/8"	10	79	166	100	4.8	4.5
GOWNN5C	GOWCC5C		1/2"	13	92	170	100	4.7	4.1
GOWNN5C	GOWCC5C		3/4"	18	111	193	125	4.7	4.1
GOWNN5C	GOWCC5C		1"	23	120	230	160	6.3	6.7
GOWNN5C	GOWCC5C		1 1/4"	29	152	246	160	8.8	9.0
GOWNN5C	GOWCC5C		1 1/2"	33	172	283	180	12.4	12.1
GOWNN5C	GOWCC5C		2"	43	220	325	200	17.5	17

GLOBE VALVE

NPT (PIPE THREAD END CONNECTIONS)

SW (SOCKET WELD END CONNECTIONS)

B.B (Bolted Bonet)

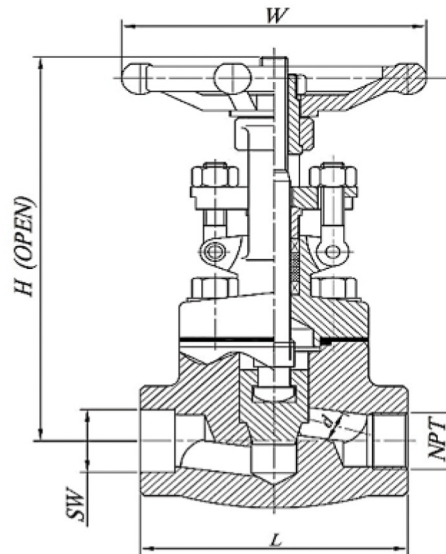

Features and Applications

- Construction: B.B (OS & Y)
- Gasket: Stainless Steel + graphite
- Socket Welding & Threaded ends
- Integral seat
- Design & manufacture: API 602 & ANSI B 16.34
- Socket welding dimension: ANSI B 16.11
- Screw end dimension: ANSI B1.20.1 (NPT)
- Inspect and test: API 598
- Body material: A105, LF2, F5, F11, F22, F304L, F316L
- All dimensions could be considered as reference.

PAP Part Number		CLASS	Nominal Diameter	Size				Weight	
NPT	SW			d	L	H(Open)	W	B,B	W.B
				mm	mm	mm	mm	Kg	
GOBNN5C	GOBCC5C	1500	3/8"	10	79	166	100	4.8	4.5
GOBNN5C	GOBCC5C		1/2"	13	92	170	100	4.7	4.1
GOBNN5C	GOBCC5C		3/4"	18	111	193	125	4.7	4.1
GOBNN5C	GOBCC5C		1"	23	120	230	160	6.3	6.7
GOBNN5C	GOBCC5C		1 1/4"	29	152	246	160	8.8	9
GOBNN5C	GOBCC5C		1 1/2"	33	172	283	180	12.4	12.1
GOBNN5C	GOBCC5C		2"	43	220	325	200	17.5	17