



**PAP** PETRO ARTAN PART

# ORIFICE FLANGES

- ANSI Orifice Flanges
- Class 300 Flanges
- Class 400 Flanges
- Class 600 Flanges
- Class 900 Flanges
- Class 1500 Flanges
- Class 2500 Flanges

# ANSI ORIFICE FLANGES

## (ANSI B16.36) Forged Flanges

ORIFICE FLANGES are widely used in conjunction with orifice meters for measuring the rate of flow of liquids and gases. They are basically the same as standard welding neck, slip-on and screwed flanges except for the provision of radial, tapped holes in the flange ring for meter connections and additional bolts to act as jack screws to facilitate separating the flanges for inspection or replacement of the orifice plate.

### NOTES :

#### ■ JACK SCREW PROVISION

- (1) Each Flange shall have a machine bolt mounted in a hole drilled on the flange centerline at 90 deg. from the pressure taps, for use as a jackscrew. Machine bolt shall be regular, with one heavy hex, nut.
- (2) A slot shall be provided in the flange 0.06 in. (1.6mm) wider than the width across flats of the nut. The depth of the slot shall admit the nut so that there is no interference with the joining of the flanges when bolted together without orifice plate.

#### ■ PRESSURE TAPS

- (1) Each orifice flange is provided with two pressure tap holes extending radially from the outside diameter of the flange to the inside diameter of the flange. Corner taps may be used on NPS 1 1/2 and smaller if space permits. Each pressure tap hole shall be equipped with a pipe plug.
- (2) The 0.94 in. (23.8) locating dimension for raised face and 0.75 in. (19.1mm) for ring joint shall be measured at the bore.
- (3) Each pressure tap hole shall be equipped with a pipe plug.

#### ■ FACING

The finish of Contact Faces Shall Conform to the Requirements of ASME / ANSI B 16.5

#### ■ FLANGE THREADS

- (1) Threaded flanges shall have an American National Standard taper pipe thread conforming to ANSI B 2.1
- (2) The thread shall be concentric with the axis of the flange and variations in alignment shall not exceed 0.06 in (1.6mm) per foot.
- (3) The flanges are made with counterbored at the back of the flange and the threads shall be chamfered to the diameter of the counterbore at an angle of approximately 45 degrees with the axis of the thread to afford easy entrance in making a joint. The chamfer shall be concentric with the thread.
- (4) In order to permit the pipe to be inserted to the flange, the threads should have full root diameters through to the face of the flange, or shall have a counterbore at the face of the flange.
- (5) The gaging notch of the working gage shall come flush with the bottom of the chamfer in all threaded flanges and shall be considered as being the intersection of the chamfer cone and the pitch cone of the thread. This depth of chamfer is approximately equal to 1/2 of the pitch of the thread.
- (6) The maximum allowable thread variation is one turn large or small from the gaging notch.

#### ■ TOLERANCES

Tolerances on all dimensions shall be as shown ANSI B16.5 except for those shown below.

- (1) Tolerance on location of center of pressure tap hole from flange face shall be :
  - a. Flanges smaller than nominal size  $4 \pm 0.02$  in (0.5mm)
  - b. Flanges nominal size 4 and larger  $\pm 0.03$  in (0.8mm)
- (2) Bore diameter tolerance (welding neck flanges only) is  $\pm 0.5\%$  of nominal value.

**CLASS 300 ORIFICE FLANGES**

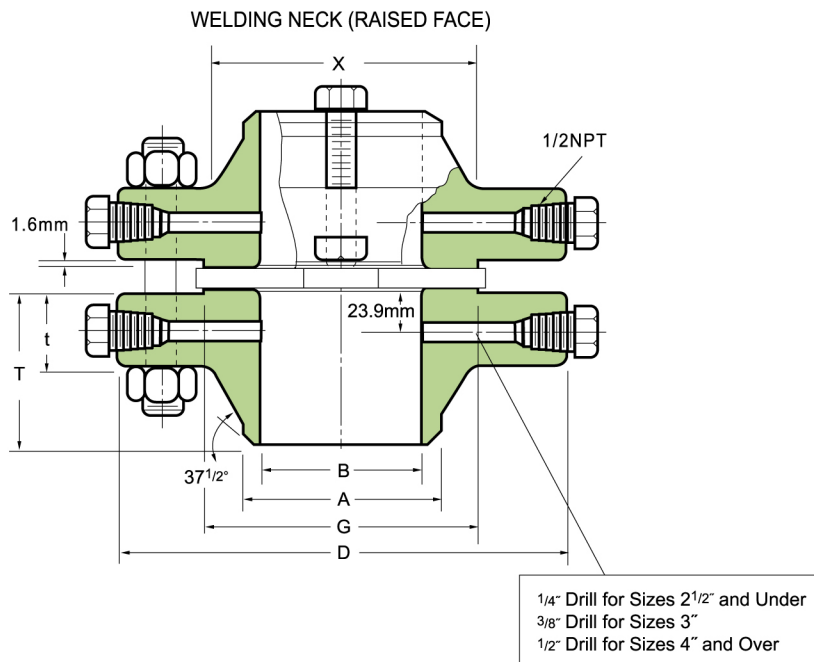

**ANSI B 16.36 Forged Flanges**

Unit : mm

Nominal Pipe Size	Outside Diam. of Flange <b>D</b>	THICKNESS OF FLANGE (t)		Diam. of Hub at Base <b>X</b>	Diam. of Raised Base <b>G</b>	Diam. of Hub of Bevel <b>A</b>	LENGTH THRU HUB (T)		BORE (B)	
		Raised Face	Slip-on & Threaded				Welding Neck	Slip-on		
									Welding Neck	Slip-on & Threaded
1	124	38.1	47.8	53.8	50.8	33.5	82.6	47.8	26.7	34.5
1 1/4	133	38.1	46.0	63.5	63.5	42.2	84.1	46.0	35.1	43.2
1 1/2	155	38.1	47.8	69.9	73.2	48.3	85.9	47.8	40.9	49.5
2	165	38.1	49.3	84.1	91.9	60.5	85.9	49.3	52.6	62.0
2 1/2	191	38.1	50.8	100.1	104.6	73.2	88.9	50.8	62.7	74.7
3	210	38.1	52.3	117.3	127.0	88.9	88.9	52.3	78.0	90.7
4	254	38.1	53.8	146.1	157.2	114.3	91.9	53.8	102.4	116.1
5	279	38.1	53.8	177.8	185.7	141.2	101.6	53.8	128.3	143.8
6	318	38.1	53.8	206.2	215.9	168.4	100.1	53.8	154.2	170.7
8	381	41.1	62.0	260.4	269.7	219.2	111.3	62.0	202.7	221.5
10	445	47.8	66.5	320.5	323.9	273.1	117.3	66.5	254.5	276.4
12	521	50.8	73.2	374.7	381.0	323.9	130.0	73.2	304.8	327.2
14	584	53.8	76.2	425.5	412.8	355.6	142.7	76.2	336.6	359.2
16	648	57.2	82.6	482.6	469.9	406.4	146.1	82.6	387.4	410.5
18	711	60.5	88.9	533.4	533.4	457.2	158.8	88.9	438.2	461.8
20	775	63.5	95.3	587.2	584.2	508.0	162.1	95.3	489.0	513.1
24	914	69.9	106.4	701.5	692.2	609.6	168.1	106.4	590.6	616.0

NOTE :

1. For the 'Bore' (B) of Welding Neck Flanges other than Standard Wall Thickness, refer to 46.47
2. Class 300 Welding Neck Flanges of sizes 24" (609.6mm) and smaller will be bored to match Standard Wall Pipe unless otherwise specified.
3. Class 300 Orifice Flanges will be furnished with 0.06" (1.6mm) raised face, which is included in 'Thickness' (t) and 'Length through Hub' (T)
4. Bolt lengths for raised face flanges include allowance for orifice and gasket thickness of 0.25" (6.4mm) for NPS 1-12 and 0.38" (9.7mm) for sizes 14-24

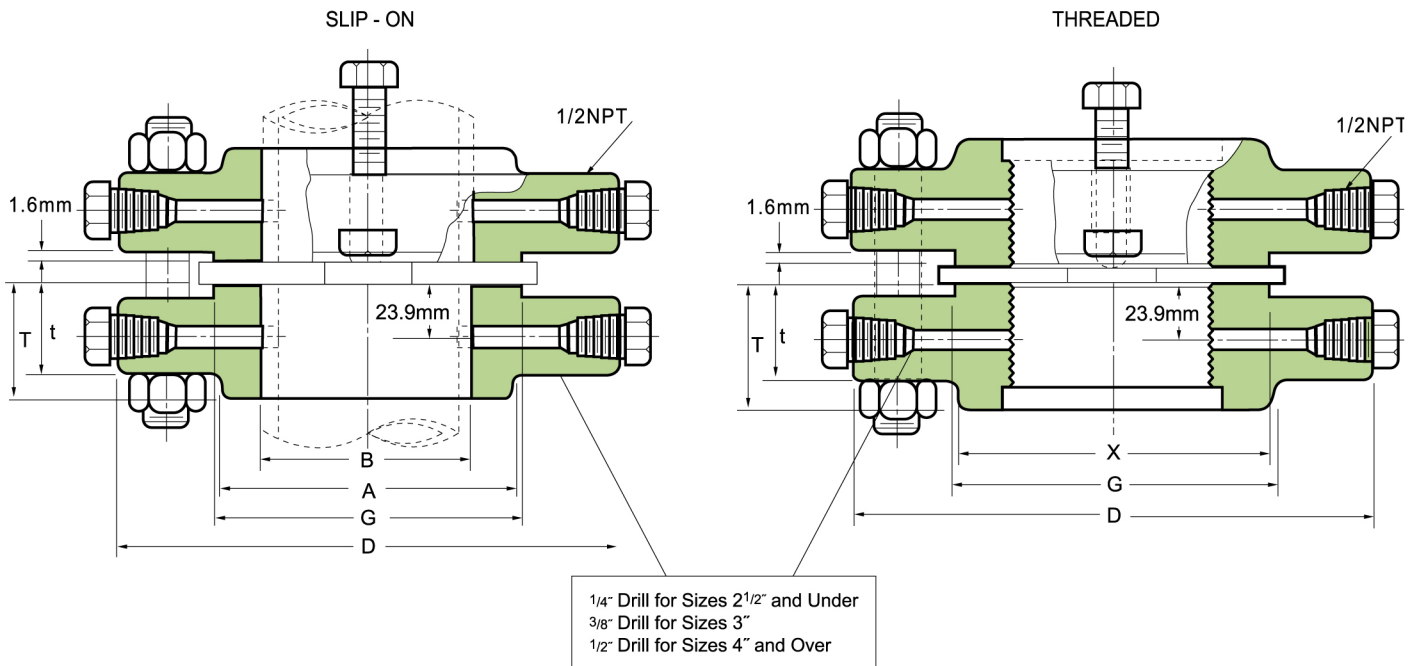

Unit : mm

Nominal Pipe Size	Pitch Diam. of Ring and Groove <b>P</b>	Ring Number	DEPTH OF JACK SCREW SLOT		DRILLING TEMPLATE				
			Raised Face	JACK SCREW SIZE Raised Face	Diam. of Bolt Circle	Number of Bolts	Diam. of Stud Bolts (inch)	Diam. of Bolts Holes	Length of Stud Bolts Raised Face
1	50.8	R16	9.7	Jack screw size for 1 thru 24 are those shown for length and diameter of bolts.	88.9	4	5/8	17.5	139.7
1 1/4	60.3	R18	9.7		98.6	4	5/8	17.5	152.4
1 1/2	68.3	R20	12.7		114.3	4	3/4	20.6	152.4
2	82.6	R23	9.7		127.0	8	5/8	17.5	152.4
2 1/2	101.6	R26	12.7		149.4	8	3/4	20.6	152.4
3	123.8	R31	12.7		168.1	8	3/4	20.6	152.4
4	149.2	R37	12.7		200.2	8	3/4	20.6	152.4
5	181.0	R41	12.7		235.0	8	3/4	22.4	152.4
6	211.1	R45	12.7		269.7	12	3/4	22.4	152.4
8	269.9	R49	15.7		330.2	12	7/8	25.4	158.8
10	323.9	R53	19.1		387.4	16	1	28.4	165.1
12	381.0	R57	22.4		450.9	16	1 1/8	31.8	177.8
14	419.1	R61	22.4		514.4	20	1 1/8	31.8	184.2
16	469.9	R65	25.4		571.5	20	1 1/4	35.1	196.9
18	533.4	R69	25.4		628.7	24	1 1/4	35.1	203.2
20	584.2	R73	25.4		685.8	24	1 1/4	35.1	215.9
24	692.2	R77	31.8		812.8	24	1 1/2	41.1	241.3

NOTE :

5. Unless otherwise specified, unions of 1 (25.4mm) thru 24 (609.6mm) furnished with carbon steel regular square headed bolts with semifinished American Standard heavy series hex nuts.

# CLASS 400 ORIFICE FLANGES

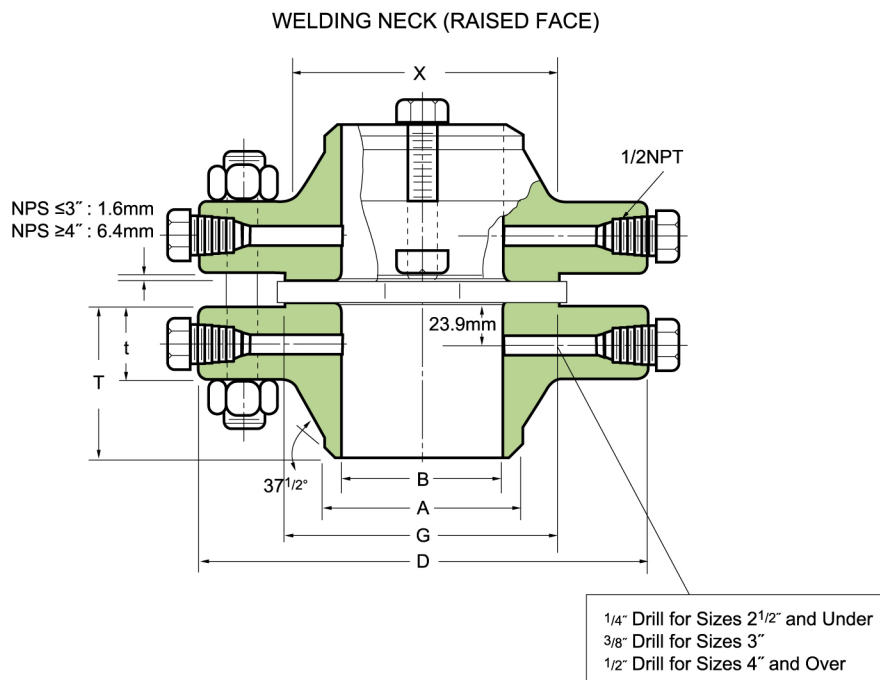

## ANSI B 16.36 Forged Flanges

Unit : mm

Nominal Pipe Size	Outside Diam. of Flange D	THICKNESS OF FLANGE (t)		Diam. of Hub at Base X	Diam. of Raised Base G	Diam. of Hub of Bevel A	LENGTH THRU HUB (T)				BORE (B)	
		Raised Face	Ring Joint				Welding Neck		Slip-on & Threaded		Welding Neck	Slip-on
							Raised Face	Ring Joint	Raised Face	Ring Joint		
1	124	38.1	31.8	53.8	50.8	33.5	82.6	76.2	47.8	41.1	See Note 1. To be specified by purchaser	34.5
1 1/4	133	38.1	31.8	63.5	63.5	42.2	84.1	77.7	46.0	39.6		43.2
1 1/2	155	38.1	31.8	69.9	73.2	48.3	85.9	79.2	47.8	41.1		49.5
2	165	38.1	31.8	84.1	91.9	60.5	85.9	79.2	49.3	42.9		62.0
2 1/2	191	38.1	31.8	100.1	104.6	73.2	88.9	82.6	50.8	44.5		74.7
3	210	38.1	31.8	117.3	127.0	88.9	88.9	82.6	52.3	46.0		90.7
4	254	35.1	35.1	146.1	157.2	114.3	88.9	88.9	50.8	50.8		116.1
5	279	38.1	38.1	177.8	185.7	141.2	101.6	101.6	53.8	53.8		143.8
6	318	41.1	41.1	206.2	215.9	168.4	103.1	103.1	57.2	57.2		170.7
8	381	47.8	47.8	260.4	269.7	219.2	117.3	117.3	68.3	68.3		221.5
10	445	53.8	53.8	320.5	323.9	273.1	124.0	124.0	73.2	73.2		276.4
12	521	57.2	57.2	374.7	381.0	323.9	136.7	136.7	79.2	79.2		327.2
14	584	60.7	60.7	425.5	412.8	355.6	149.4	149.4	-	-		359.2
16	648	63.5	63.5	482.6	469.9	406.4	152.4	152.4	-	-		410.5
18	711	66.5	66.5	533.4	533.4	457.2	165.1	165.1	-	-		461.8
20	775	69.9	69.9	587.2	584.2	508.0	168.1	168.1	-	-		513.1
24	914	76.2	76.2	701.5	692.2	609.6	174.8	174.8	-	-		564.4

NOTE :

- For the inside diameter of pipes (corresponding to 'Bore' (B) of Welding Neck Flanges), refer to page 46,47
- Class 400 Flanges of sizes 3" and smaller will be furnished with 0.06" (1.6mm) raised face, which is included in 'Thickness' (t) and 'Length through Hub' (T)  
The 0.25" (6.35mm) raised face for sizes 4" and larger is not included in (t) and (T)
- Each union includes two carbon steel jack screw bolts with hex nuts.

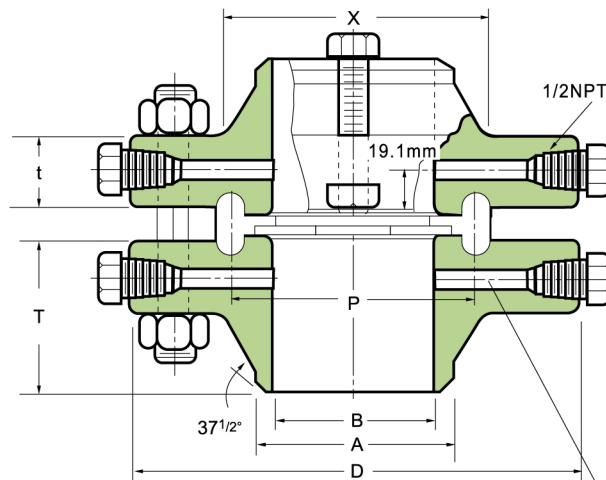
**WELDING NECK (RING-TYPE JOINT)**

1/4" Drill for Sizes 2 1/2" and Under  
 3/8" Drill for Sizes 3"  
 1/2" Drill for Sizes 4" and Over

Unit : mm

Nominal Pipe Size	Pitch Diam. of Ring and Groove <b>P</b>	Ring Number	DEPTH OF JACK SCREW SLOT		JACK SCREW SIZE		DRILLING TEMPLATE					
			Raised Face	Ring Joint	Raised Face (inch)	Ring Joint (inch)	Diam. of Bolt Circle	Number of Bolts	Diam. of Stud Bolts (inch)	Diam. of Bolts Holes	Length of Stud Bolts	
											Raised Face	Ring Joint
1	50.8	R16	9.7	6.4	5/8X4.00	5/8X4.75	88.9	4	5/8	17.5	127.0	146.1
1 1/4	60.3	R18	9.7	6.4	5/8X4.00	5/8X4.75	98.6	4	5/8	17.5	127.0	120.7
1 1/2	68.3	R20	12.7	6.4	3/4X4.25	3/4X5.00	114.3	4	3/4	21.0	133.4	152.4
2	82.6	R23	9.7	6.4	5/8X4.00	5/8X4.75	127.0	8	5/8	17.5	127.0	152.4
2 1/2	101.6	R26	12.7	6.4	3/4X4.25	3/4X5.00	149.4	8	3/4	20.6	133.4	158.8
3	123.8	R31	12.7	6.4	3/4X4.25	3/4X5.00	168.1	8	3/4	20.6	133.4	158.8
4	149.2	R37	6.4	15.7	3/4X3.00	3/4X4.00	200.2	8	7/8	25.4	139.7	152.4
5	181.0	R41	6.4	15.7	3/4X3.00	3/4X4.00	235.0	8	7/8	25.4	146.1	158.8
6	211.1	R45	12.7	22.4	1X3.50	1X4.00	269.7	12	7/8	25.4	158.8	165.1
8	269.9	R49	12.7	22.4	1X3.50	1X4.50	330.2	12	1	28.4	171.5	184.2
10	323.9	R53	12.7	22.4	1X4.00	1X4.50	387.4	16	1 1/8	31.8	190.5	203.2
12	381.0	R57	12.7	22.4	1X4.00	1X5.00	450.9	16	1 1/4	35.1	203.2	215.9
14	419.1	R61	12.7	22.4	1X4.25	1X5.00	514.4	20	1 1/4	35.1	209.6	228.6
16	469.9	R65	12.7	22.4	1X4.25	1X5.00	571.5	20	1 3/8	38.1	222.3	235.0
18	533.4	R69	12.7	22.4	1X4.50	1X5.00	628.7	24	1 3/8	38.1	235.0	241.3
20	584.2	R73	12.7	22.4	1X4.75	1X5.50	685.8	24	1 1/2	41.1	247.7	260.4
24	692.2	R77	12.7	22.4	1X5.00	1X6.00	812.8	24	1 3/4	47.8	279.4	285.8

**NOTE :**

- Unless otherwise specified, raised face unions are furnished with alloy bolt studs per ASTM A193 Grade B7 with American Standard heavy series hex nuts ASTM A194 Class 2H.
- On ring joint flanges having a groove depth 0.375" (9.5mm) and less, the distance from the center line of the tap hole to the flange face is 0.750" (19.1mm). When the depth of groove is 0.438" (11.1mm) or greater, changes in drill size or method of drilling are necessary.
- Bolt lengths for raised face flanges include allowance for orifice and gasket thickness of 0.25" (6.4mm) for sizes 4-12 and 0.38" (9.7mm) for sizes 14-24. Bolt lengths for ring type joint flanges include allowance of 0.62" (15.7mm) for sizes 4-10, 0.75" (19.1mm) for sizes 12-18 and 0.88" (22.4mm) for size 20.

# CLASS 600 ORIFICE FLANGES

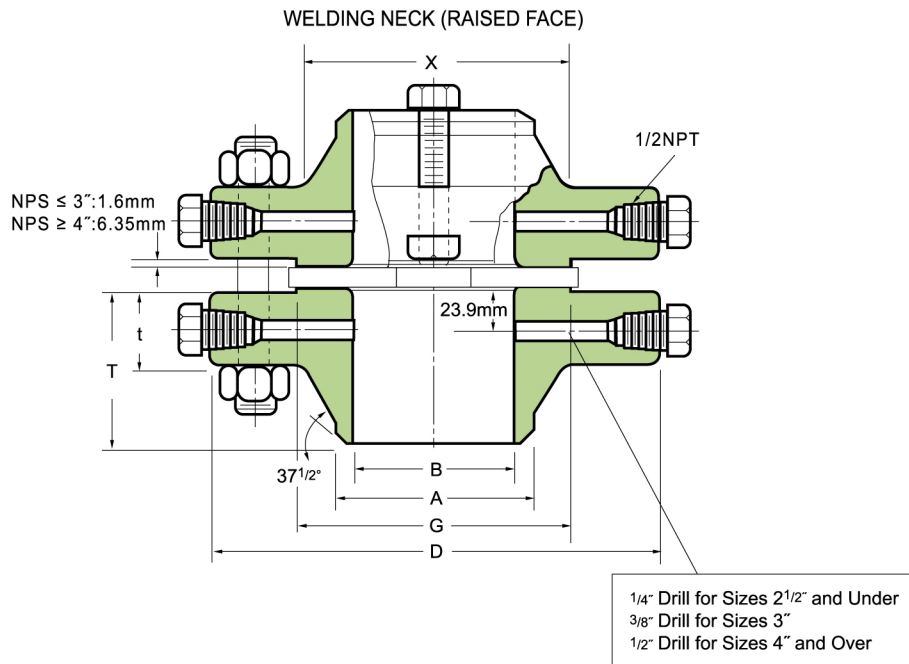

## ANSI B 16.36 Forged Flanges

Unit : mm

Nominal Pipe Size	Outside Diam. of Flange D	THICKNESS OF FLANGE (t)		Diam. of Hub at Base X	Diam. of Raised Base G	Diam. of Hub of Bevel A	LENGTH THRU HUB (T)				BORE (B)	
		Raised Face	Ring Joint				Welding Neck		Slip-on & Threaded		Welding Neck	Slip-on
							Raised Face	Ring Joint	Raised Face	Ring Joint		
1	124	38.1	31.8	53.8	50.8	33.5	82.6	76.2	47.8	41.1	See Note 1. To be specified by purchaser	34.5
1 1/4	133	38.1	31.8	63.5	63.5	42.2	84.1	77.7	46.0	39.6		43.2
1 1/2	155	38.1	31.8	69.9	73.2	48.3	85.9	79.2	47.8	41.1		49.5
2	165	38.1	31.8	84.1	91.9	60.5	85.9	79.2	49.3	42.9		62.0
2 1/2	191	38.1	31.8	100.1	104.6	73.2	88.9	82.6	50.8	44.5		74.7
3	210	38.1	31.8	117.3	127.0	88.9	88.9	82.6	52.3	46.0		90.7
4	273	38.1	38.1	152.4	157.2	114.3	101.6	101.6	53.8	53.8		116.1
5	330	44.5	44.5	189.0	185.7	141.2	114.3	114.3	60.5	60.5		143.8
6	356	47.8	47.8	222.3	215.9	168.4	117.3	117.3	66.5	66.5		170.7
8	419	55.6	55.6	273.1	269.7	219.2	133.4	133.4	76.5	76.2		221.5
10	508	63.5	63.5	342.9	323.9	273.1	152.4	152.4	85.9	85.9		276.4
12	559	66.5	66.5	400.1	381.0	323.9	155.4	155.4	91.9	91.9		327.2
14	603	69.9	69.9	431.8	412.8	355.6	165.4	165.1	-	-		-
16	686	76.2	76.2	495.3	469.9	406.4	177.8	177.8	-	-		-
18	743	82.6	82.6	546.1	533.4	457.2	184.2	184.2	-	-		-
20	813	88.9	88.9	609.6	584.2	508.0	190.5	190.5	-	-		-
24	940	101.6	101.6	717.6	692.2	609.6	203.2	203.2	-	-		-

**NOTE :**

- For the inside diameter of pipes (corresponding to 'Bore' (B) of Welding Neck Flanges), refer to page 46,47
- Class 600 Flanges of sizes 3" and smaller will be furnished with 0.06" (1.6mm) raised face, which is included in 'Thickness' (t) and 'Length through Hub' (T) The 0.25" (6.35mm) raised face for sizes 4" and larger is not included in (t) and (T)
- Each union includes two carbon steel jack screw bolts with hex nuts.
- Bolt lengths for raised face flanges include allowance for orifice and gasket thickness of 0.25" (6.4mm) for sizes 1-12 and 0.38" (9.7mm) for sizes 14-24. Bolt lengths for ring type joint flanges include allowance of 0.62" (15.7mm) for sizes 1-10, 0.75" (19.1mm) for sizes 12-18 and 0.88" (22.4mm) for size 20.

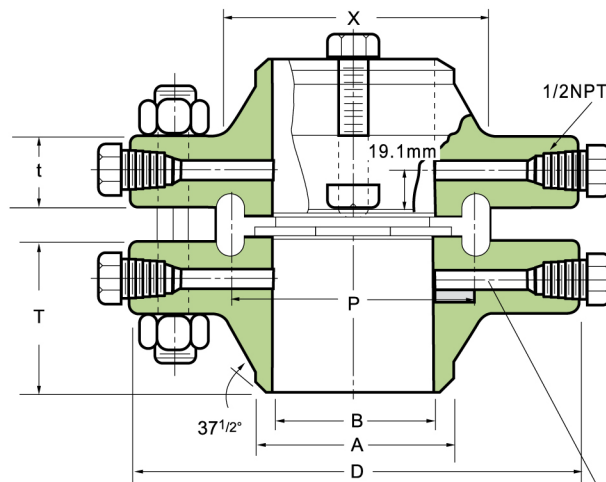
**WELDING NECK (RING-TYPE JOINT)**

1/4" Drill for Sizes 2 1/2" and Under  
 3/8" Drill for Sizes 3"  
 1/2" Drill for Sizes 4" and Over

Unit : mm

Nominal Pipe Size	Pitch Diam. of Ring and Groove  P	Ring Number	DEPTH OF JACK SCREW SLOT		JACK SCREW SIZE		DRILLING TEMPLATE						
			Raised Face	Ring Joint	Raised Face (inch)	Ring Joint (inch)	Diam. of Bolt Circle	Number of Bolts	Diam. of Stud Bolts (inch)	Diam. of Stud Bolts Holes		Length of Stud Bolts	
										RF	RTJ	Raised Face	Ring Joint
1	50.8	R16	9.7	6.4	5/8X4.00	5/8X4.75	88.9	4	5/8	17.5	19.1	127.0	146.1
1 1/4	60.3	R18	9.7	6.4	5/8X4.00	5/8X4.75	98.6	4	5/8	17.5	-	127.0	120.7
1 1/2	68.3	R20	12.7	6.4	3/4X4.25	3/4X5.00	114.3	4	3/4	20.6	22.4	133.4	152.4
2	82.6	R23	9.7	6.4	5/8X4.00	5/8X4.75	127.0	8	5/8	17.5	19.7	127.0	152.4
2 1/2	101.6	R26	12.7	6.4	3/4X4.25	3/4X5.00	149.4	8	3/4	20.6	22.4	133.4	158.8
3	123.8	R31	12.7	6.4	3/4X4.25	3/4X5.00	168.1	8	3/4	20.6	22.4	133.4	158.8
4	149.2	R37	6.4	15.7	3/4X3.00	3/4X4.00	215.9	8	7/8	25.4	25.4	152.4	165.1
5	181.0	R41	6.4	15.7	3/4X3.50	3/4X4.50	266.7	8	1	28.4	28.4	139.7	177.8
6	211.1	R45	12.7	22.4	1X4.00	1X4.50	292.1	12	1	28.4	28.4	177.8	190.5
8	269.9	R49	12.7	22.4	1X4.00	1X4.75	349.3	12	1 1/8	31.8	31.8	196.9	209.6
10	323.9	R53	12.7	22.4	1X4.00	1X5.00	431.8	16	1 1/4	35.1	35.1	222.3	235.0
12	381.0	R57	12.7	22.4	1X4.50	1X5.00	489.0	20	1 1/4	35.1	35.1	228.6	241.3
14	419.1	R61	12.7	22.4	1X5.00	1X5.50	527.1	20	1 3/8	38.1	38.1	241.3	254.0
16	469.9	R65	12.7	22.4	1X5.00	1X5.50	603.3	20	1 1/2	41.1	41.1	260.4	273.1
18	533.4	R69	12.7	22.4	1X5.00	1X5.75	654.1	20	1 5/8	44.5	44.5	297.4	292.1
20	584.2	R73	12.7	22.4	1X6.00	1X6.25	723.9	24	1 5/8	44.5	44.5	298.5	317.5
24	692.2	R77	12.7	22.4	1X6.00	1X7.00	838.2	24	1 7/8	50.8	50.8	336.6	342.9

**NOTE :**

- Unless otherwise specified, raised face unions are furnished with alloy bolt studs per ASTM A193 Grade B7 with American Standard heavy series hex nuts ASTM A194 Class 2H.
- On ring joint flanges having a groove depth 0.375" (9.5mm) and less, the distance from the center line of the tap hole to the flange face is 0.750" (19.1mm). When the depth of groove is 0.438" (11.1mm) or greater, changes in drill size or method of drilling are necessary.



**CLASS 900 / 1500 ORIFICE FLANGES**

WELDING NECK  
(RAISED FACE)

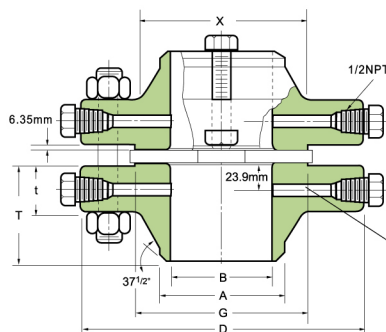

1/4" Drill for Sizes 2 1/2" and Under  
3/8" Drill for Sizes 3"  
1/2" Drill for Sizes 4" and Over

**ANSI B 16.36 Forged Flanges**

Unit : mm

Nominal Pipe Size	Outside Diam. of Flange D	THICKNESS OF FLANGE (t)		Diam. of Hub at Base X	Diam. of Raised Base G	Diam. of Hub of Bevel A	LENGTH THRU HUB (T)				BORE (B)	
		Raised Face	Ring Joint				Welding Neck		Slip-on & Threaded		Welding Neck	Slip-on
							Raised Face	Ring Joint	Raised Face	Ring Joint		
<b>CLASS 900</b>												
3	241	38.1	38.1	127.0	127.0	88.9	101.6	101.6	53.8	53.8	To be specified by purchaser	90.7
4	292	44.5	44.5	158.8	157.2	114.3	114.3	114.3	69.9	69.9		116.1
5	349	50.8	50.8	190.5	185.7	141.2	127.0	127.0	79.2	79.2		143.8
6	381	55.6	55.6	235.0	215.9	168.4	139.7	139.7	85.9	85.9		170.7
8	470	63.5	63.5	298.5	269.7	219.2	162.1	162.1	101.6	101.6		221.5
10	546	69.9	69.9	368.3	323.9	273.1	184.2	184.2	108.0	108.0		276.4
12	610	79.2	79.2	419.1	381.0	323.9	200.2	200.2	117.3	117.3		327.2
14	641	85.9	-	450.9	412.8	355.6	212.9	-	-	-		-
16	705	88.9	-	508.0	469.9	406.4	215.9	-	-	-		-
18	787	101.6	-	565.2	533.4	457.2	228.6	-	-	-		-
20	857	108.0	-	622.3	584.2	508.0	247.7	-	-	-	-	
24	1041	139.7	-	749.3	692.2	609.6	292.1	-	-	-	-	
<b>CLASS 1500</b>												
1	149	38.1	38.1	52.3	50.8	33.5	82.6	82.6	47.8	44.5	To be specified by purchaser	34.5
1 1/4	158	35.1	35.1	63.5	63.5	42.2	73.2	73.2	47.8	44.5		43.2
1 1/2	178	38.1	38.1	69.9	73.2	48.3	88.9	88.9	47.8	44.5		49.5
2	216	38.1	38.1	104.6	91.9	60.5	101.6	101.6	57.2	57.2		62.0
2 1/2	244	41.1	41.1	124.0	104.6	73.2	104.6	104.6	63.5	63.5		74.7
3	267	47.8	47.8	133.4	127.0	88.9	117.3	117.3	73.2	73.2		90.7
4	311	53.8	53.8	162.1	157.2	114.3	124.0	124.0	90.4	90.4		116.1
5	375	73.2	73.2	196.9	185.7	141.2	155.4	104.6	104.6	104.6		143.8
6	394	82.6	82.6	228.6	215.9	168.4	171.5	171.5	119.1	119.1		170.7
8	483	91.9	91.9	292.1	269.7	219.2	212.9	212.9	142.7	142.7		221.5
10	584	108.0	108.0	368.3	323.9	273.1	254.0	254.0	158.8	158.5	276.4	
12	673	124.0	124.0	450.9	381.0	323.9	282.4	282.4	180.8	180.8	327.2	
14	749	133.4	-	495.3	412.8	355.6	298.5	-	-	-	-	
16	826	146.1	-	552.5	469.9	406.4	311.2	-	-	-	-	
18	914	162.1	-	596.9	533.4	457.2	327.2	-	-	-	-	
20	984	177.8	-	641.4	584.2	508.0	355.6	-	-	-	-	
24	1168	203.2	-	762.0	692.2	609.6	406.4	-	-	-	-	

- NOTE :
1. For the inside diameter of pipes (corresponding to 'Bore' (B) of Welding Neck Flanges), refer to page 46,47
  2. Class 900 Flanges of sizes 1" (25.4mm) through 2 1/2" are the same as for Class 1500.
  3. Class 900 and 1500 is not included in "thickness' (t) and 'Length through Hub' (t).
  4. Each union includes two carbon steel jack screw bolts with hex nuts.

WELDING NECK  
(RING-TYPE JOINT)

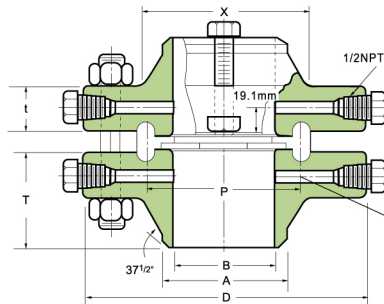

1/4" Drill for Sizes 2 1/2" and Under  
3/8" Drill for Sizes 3"  
1/2" Drill for Sizes 4" and Over

Unit : mm

Nominal Pipe Size	Pitch Diam. of Ring and Groove  P	Ring Number	DEPTH OF JACK SCREW SLOT		JACK SCREW SIZE		DRILLING TEMPLATE					
			Raised Face	Ring Joint	Raised Face (inch)	Ring Joint (inch)	Diam. of Bolt Circle	Number of Bolts	Diam. of Stud Bolts (inch)	Diam. of Bolts Holes	Length of Stud Bolts	
											Raised Face	Ring Joint
<b>CLASS 900</b>												
3	123.8	R31	9.7	15.7	3/4X3.50	3/4X4.00	190.5	8	7/8	25.4	152.4	165.1
4	149.2	R37	9.7	15.7	3/4X3.50	3/4X4.50	235.0	8	1 1/8	31.8	177.8	190.5
5	181.0	R41	9.7	15.7	3/4X3.50	3/4X4.50	279.4	8	1 1/4	35.1	190.5	203.2
6	211.1	R45	15.7	22.4	1X4.50	1X4.75	317.5	12	1 1/8	31.8	196.9	209.6
8	269.9	R49	15.7	22.4	1X4.50	1X5.00	393.7	12	1 3/8	38.1	228.6	241.3
10	323.9	R53	15.7	22.4	1X4.50	1X5.25	469.9	16	1 3/8	38.1	241.3	254.0
12	381.0	R57	15.7	22.4	1X4.50	1X5.50	533.4	20	1 3/8	38.1	260.4	273.1
14	-	-	-	-	-	-	558.8	20	1 1/2	41.1	279.4	-
16	-	-	-	-	-	-	616.0	20	1 5/8	44.5	292.1	-
18	-	-	-	-	-	-	685.8	20	1 7/8	50.8	330.2	-
20	-	-	-	-	-	-	749.3	20	2	53.8	355.6	-
24	-	-	-	-	-	-	901.7	20	2 1/2	66.5	444.5	-
<b>CLASS 1500</b>												
1	50.8	R16	6.4	12.7	5/8X3.00	5/8X3.50	101.6	4	7/8	25.4	152.4	158.8
1 1/4	60.3	R18	6.4	12.7	5/8X3.00	5/8X3.50	111.3	4	7/8	25.4	139.7	146.1
1 1/2	68.3	R20	6.4	12.7	5/8X3.00	5/8X3.50	124.0	4	1	28.4	158.8	165.1
2	95.3	R24	6.4	12.7	5/8X3.00	5/8X4.00	165.1	8	7/8	25.4	152.4	165.1
2 1/2	108.0	R27	6.4	12.7	5/8X3.00	5/8X4.00	190.5	8	1	28.4	165.1	177.8
3	136.5	R35	9.7	15.7	5/8X3.50	3/4X4.50	203.2	8	1 1/8	31.8	184.2	196.9
4	161.9	R39	9.7	15.7	5/8X3.50	3/4X4.50	241.3	8	1 1/4	35.1	203.2	215.9
5	193.7	R44	9.7	15.7	5/8X3.50	3/4X4.50	292.1	8	1 1/2	41.1	247.7	260.4
6	211.1	R46	15.8	22.4	1X6.00	1X6.50	317.5	12	1 3/8	38.1	266.7	279.4
8	269.9	R50	15.7	22.4	1X6.50	1X6.50	393.7	12	1 5/8	44.5	298.5	317.5
10	323.9	R54	15.7	22.4	1X6.50	1X7.00	482.6	12	1 7/8	50.8	342.9	362.0
12	381.0	R58	15.7	22.4	1X6.50	1X8.00	571.5	16	2	53.8	381.0	406.4
14	-	-	-	-	-	-	635.0	16	2 1/4	60.5	412.8	-
16	-	-	-	-	-	-	704.9	16	2 1/2	66.5	450.9	-
18	-	-	-	-	-	-	774.7	16	2 3/4	73.2	501.7	-
20	-	-	-	-	-	-	831.9	16	3	79.2	546.1	-
24	-	-	-	-	-	-	990.6	16	3 1/2	91.9	622.3	-

NOTE :

- Unless otherwise specified, raised face unions are furnished with alloy bolt studs per ASTM A193 Grade B7 with American Standard heavy series hex nuts ASTM A194 Class 2H.
- On ring joint flanges having a groove depth 0.375" (9.5mm) and less, the distance from the center line of the tap hole to the flange face is 0.750" (19.1mm). When the depth of groove is 0.438" (11.1mm) or greater, changes in drill size or method of drilling are necessary.
- Bolt lengths for raised face flanges include allowance for orifice and gasket thickness of 0.25" (6.4mm) for sizes 3-12 and 0.38" (9.7mm) for sizes 14-24. Bolt lengths for ring type joint flanges include allowance of 0.62" (15.7mm) for sizes 3-10, 0.75" (19.1mm) for sizes 12-18 and 0.88" (22.4mm) for size 20.

# CLASS 2500 ORIFICE FLANGES

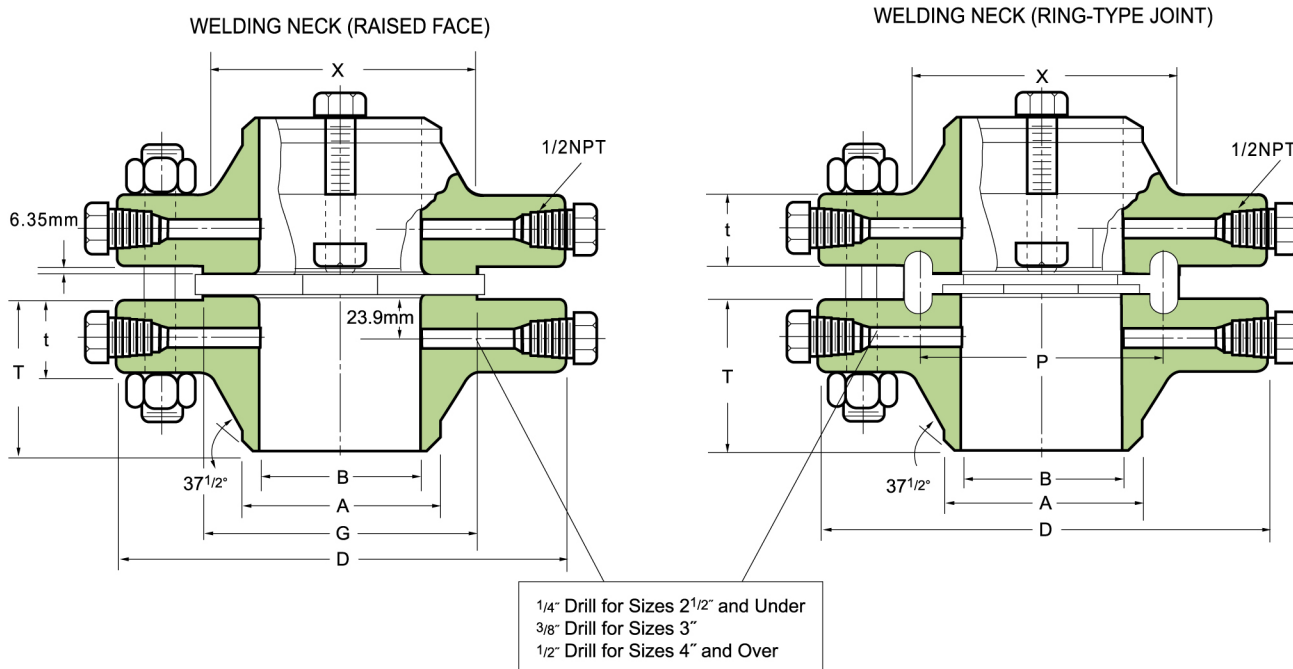

## ANSI B 16.36 Forged Flanges

Unit : mm

Nominal Pipe Size	O.D. of Flange Face	O.D. of Raised Flange	THK'S of Hub Min	Length Thru	Diam. of Hub	Diam. of Hub at Bevel	Bore	Ring Type Joing		DRILLING TEMPLATE				LENGTH OF STUD BOLTS	
								Pitch Diam.	Ring Number	Diam. Bolt Circle	Number of Holes	Diam. of Holes	Diam. of Bolts (inch)	Raised Face	Ring Joint
	D	G	t	T	X	A	B	P							
1	159	50.8	38.1	91.9	57.2	33.5	See Note 1. To be specified by purchaser	60.3	R18	108.0	4	25.4	7/8	152.4	158.8
1 1/2	203	73.2	44.5	111.3	79.2	48.3		82.6	R23	146.1	4	31.8	1 1/8	177.8	190.5
2	235	91.9	50.8	127.0	95.3	60.5		101.6	R26	171.5	8	28.4	1	184.2	196.9
2 1/2	267	104.6	57.2	142.7	114.3	73.2		111.1	R28	196.9	8	31.8	1 1/8	203.2	215.9
3	305	127.0	66.5	168.1	133.4	88.9		127.0	R32	228.6	8	35.1	1 1/4	228.6	241.3
4	356	157.2	76.2	190.5	165.1	114.3		-	-	273.1	8	41.1	1 1/2	260.4	-
6	483	215.9	108.0	273.1	235.0	168.4		-	-	368.3	8	53.8	2	349.3	-
8	552	269.7	127.0	317.5	304.8	219.2		-	-	438.2	12	53.8	2	387.4	-
10	673	323.9	165.1	419.1	374.7	273.1		-	-	539.8	12	66.5	2 1/2	489.0	-
12	762	381.0	184.2	463.6	441.5	323.9		-	-	619.3	12	73.2	2 3/4	539.8	-

**NOTE :**

- For the inside diameter of pipes (corresponding to 'Bore' (B) of Welding Neck Flanges), refer to page 46,47
- Class 2500 Flanges will be furnished with 0.25" (6.4mm) raised face, which is included in 'Thickness' (t) and 'Length through Hub' (T)
- Each union includes two carbon steel jack screw bolts with hex nuts.
- Unless otherwise specified, raised face unions are furnished with alloy bolt studs per ASTM A193 Grade B7 with American Standard heavy series hex nuts ASTM A194 Class 2H.
- On ring joint flanges having a groove depth 0.375" (9.5mm) and less, the distance from the center line of the tap hole to the flange face is 0.750" (19.1mm). When the depth of groove is 0.438" (11.1mm) or greater, changes in drill size or method of drilling are necessary.
- Class 2500 Slip-on flanges are not covered by ANSI B16.5.
- Bolt lengths for raised face flanges include allowance for orifice and gasket thickness of 0.25" (6.4mm) for sizes 1-12 and 0.38" (9.7mm) for sizes 14-24. Bolt lengths for ring type joint flanges include allowance of 0.62" (15.7mm) for sizes 1-6.