



**PAP** PETRO ARTAN PART

# LONG WELDING NECK FLANGES

- Class 150 Flanges
- Class 300 Flanges
- Class 400 Flanges
- Class 600 Flanges
- Class 900 Flanges
- Class 1500 Flanges
- Class 2500 Flanges

## CLASS 150 FLANGES

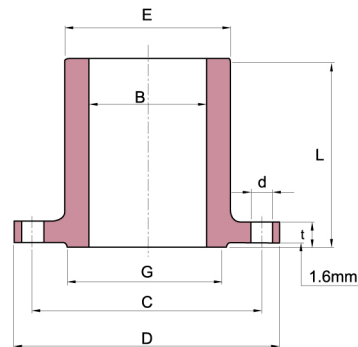

Unit : mm

Nominal Pipe Size	Outside Diam.	O.D of Raised Face	Hub Diameter of Bevel	Diameter of Bore	Thickness of Flange Min	Length Thru Hub	DRILLING		
							Diameter of Bolt Circle	Number of Holes	Diameter of Holes
	D	G	E	B	t	L	C		d
1/2	89	34.9	30.2	12.7	11.2	228.6	60.5	4	15.7
3/4	99	42.9	38.1	19.1	12.7	228.6	69.9	4	15.7
1	108	50.8	50.8	25.4	14.2	228.6	79.2	4	15.7
1 1/4	117	63.5	60.5	31.8	15.7	228.6	88.9	4	15.7
1 1/2	127	73.0	66.5	38.1	17.5	228.6	98.6	4	15.7
2	152	91.9	82.6	50.8	19.1	228.6	120.7	4	19.1
2 1/2	178	104.6	95.3	63.5	22.4	228.6	139.7	4	19.1
3	191	127.0	108.0	76.2	23.9	228.6	152.4	4	19.1
3 1/2	216	139.7	124.0	88.9	23.9	228.6	177.8	8	19.1
4	229	157.2	139.7	101.6	23.9	304.8	190.5	8	19.1
5	254	185.7	165.1	127.0	23.9	304.8	215.9	8	22.4
6	279	215.9	196.9	152.4	25.4	304.8	241.3	8	22.4
8	343	269.7	247.7	203.2	28.4	304.8	298.5	8	22.4
10	406	323.9	304.8	254.0	30.2	304.8	362.0	12	25.4
12	483	381.0	365.3	304.8	31.8	304.8	431.8	12	25.4
14	533	412.8	406.4	355.6	35.1	304.8	476.3	12	28.4
16	597	469.9	457.2	406.4	36.6	304.8	539.8	16	28.4
18	635	533.4	508.0	457.2	39.6	304.8	577.9	16	31.8
20	699	584.2	558.8	508.0	42.9	304.8	635.0	20	31.8
24	813	692.2	666.8	609.6	47.8	304.8	749.3	20	35.1

## CLASS 300 FLANGES

Unit : mm

Nominal Pipe Size	Outside Diam.	O.D of Raised Face	Hub Diameter of Bevel	Diameter of Bore	Thickness of Flange Min	Length Thru Hub	DRILLING		
							Diameter of Bolt Circle	Number of Holes	Diameter of Holes
	D	G	E	B	t	L	C		d
1/2	95	35.1	38.1	12.7	14.2	228.6	66.5	4	15.7
3/4	117	42.9	47.8	19.1	15.7	228.6	82.6	4	19.1
1	124	50.8	53.8	25.4	17.5	228.6	88.9	4	19.1
1 1/4	133	63.5	63.5	31.8	19.1	228.6	98.6	4	19.1
1 1/2	155	73.2	69.9	38.1	20.6	228.6	114.3	4	22.4
2	165	91.9	84.1	50.8	22.4	228.6	127.0	8	19.1
2 1/2	191	104.6	100.1	63.5	25.4	228.6	149.4	8	22.4
3	210	127.0	117.3	76.2	28.4	228.6	168.1	8	22.4
3 1/2	229	139.7	133.4	88.9	30.2	228.6	184.2	8	22.4
4	254	157.2	146.1	101.6	31.8	304.8	200.2	8	22.4
5	279	185.7	177.8	127.0	35.1	304.8	235.0	8	22.4
6	318	215.9	206.2	152.4	36.6	304.8	269.7	12	22.4
8	381	269.7	260.4	203.2	41.1	304.8	330.2	12	25.4
10	445	323.9	320.5	254.0	47.8	304.8	387.4	16	28.4
12	521	381.0	374.7	304.8	50.8	304.8	450.9	16	31.8
14	584	412.8	425.5	355.6	53.8	304.8	514.4	20	31.8
16	648	469.9	482.6	406.4	57.2	304.8	571.5	20	35.1
18	711	533.4	533.4	457.2	60.5	304.8	628.7	24	35.1
20	775	584.2	587.2	508.0	63.5	304.8	685.8	24	35.1
24	914	692.2	701.5	609.6	69.9	304.8	812.8	24	41.1

NOTE : 1. Bore (B) is the same as nominal pipe size.  
 2. Welding necks longer than listed are available in all sizes on special order.

**CLASS 400 FLANGES**

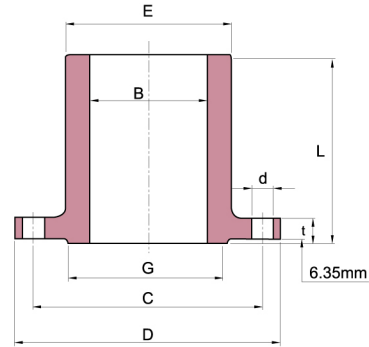

Unit : mm

Nominal Pipe Size	Outside Diam. D	O.D of Raised Face G	Hub Diameter of Bevel E	Diameter of Bore B	Thickness of Flange Min t	Length Thru Hub L	DRILLING		
							Diameter of Bolt Circle C	Number of Holes	Diameter of Holes d
1/2									
3/4									
1									
1 1/4									
1 1/2									
2									
2 1/2									
3									
3 1/2									
4	254	157.2	146.1	101.6	35.1	304.8	200.2	8	25.4
5	279	185.7	177.8	127.0	38.1	304.8	235.0	8	25.4
6	318	215.9	206.2	152.4	41.1	304.8	269.7	12	25.4
8	381	269.7	260.4	203.2	47.8	304.8	330.2	12	28.4
10	445	323.9	320.5	254.0	53.8	304.8	387.4	16	31.8
12	521	381.0	374.7	304.8	57.2	304.8	450.9	16	35.1
14	584	412.8	425.5	355.6	60.5	304.8	514.4	20	35.1
16	648	469.9	482.6	406.4	63.5	304.8	571.5	20	38.1
18	711	533.4	533.4	457.2	66.5	304.8	628.7	24	38.1
20	775	584.2	587.2	508.0	69.9	304.8	685.8	24	41.1
24	914	692.2	701.5	609.6	76.2	304.8	812.8	24	47.8

Use Class 600 dimensions in these sizes.

**CLASS 600 FLANGES**

Unit : mm

Nominal Pipe Size	Outside Diam. D	O.D of Raised Face G	Hub Diameter of Bevel E	Diameter of Bore B	Thickness of Flange Min t	Length Thru Hub L	DRILLING		
							Diameter of Bolt Circle C	Number of Holes	Diameter of Holes d
1	124	50.8	53.8	25.4	17.5	228.6	88.9	4	19.1
1 1/4	133	63.5	63.5	31.8	20.6	228.6	98.6	4	19.1
1 1/2	155	73.2	69.9	38.1	22.4	228.6	114.3	4	22.4
2	165	91.9	84.1	50.8	25.4	228.6	127.0	8	19.1
2 1/2	191	104.6	100.1	63.5	28.4	228.6	149.4	8	22.4
3	210	127.0	117.3	76.2	31.8	228.6	168.1	8	22.4
3 1/2	229	139.7	133.4	88.9	35.1	228.6	184.2	8	25.4
4	273	157.2	152.4	101.6	38.1	304.8	215.9	8	25.4
5	330	185.7	190.5	127.0	44.5	304.8	266.7	8	28.4
6	356	215.9	222.3	152.4	47.8	304.8	292.1	12	28.4
8	419	269.7	273.1	203.2	55.6	304.8	349.3	12	31.8
10	508	323.9	342.9	254.0	63.5	304.8	431.8	16	35.1
12	559	381.0	400.1	304.8	66.5	304.8	489.0	16	35.1
14	603	412.8	431.8	355.6	69.9	304.8	527.1	20	38.1
16	686	469.9	495.3	406.4	76.2	304.8	603.3	20	41.1
18	743	533.4	546.1	457.2	82.6	304.8	654.1	20	44.5
20	813	584.2	609.6	508.0	88.9	304.8	723.9	24	44.5
24	940	692.2	717.6	609.6	101.6	304.8	838.2	24	50.8

NOTE : 1. Bore (B) is the same as nominal pipe size.  
2. Welding necks longer than listed are available in all sizes on special order.

**CLASS 900 FLANGES**

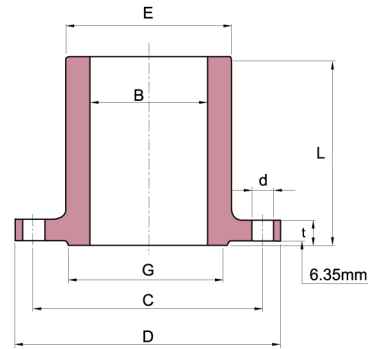

Unit : mm

Nominal Pipe Size	Outside Diam.	O.D of Raised Face	Hub Diameter of Bevel	Diameter of Bore	Thickness of Flange Min	Length Thru Hub	DRILLING		
							Diameter of Bolt Circle	Number of Holes	Diameter of Holes
	D	G	E	B	t	L	C		d
1									
1 1/4									
1 1/2									
2									
2 1/2									
3	241	127.0	127.0	76.2	38.1	304.8	190.5	8	22.4
4	292	157.2	158.8	101.6	44.5	304.8	235.0	8	31.8
5	349	185.7	190.5	127.0	50.8	304.8	279.4	8	35.1
6	381	215.9	235.0	152.4	55.6	304.8	317.5	12	31.8
8	470	269.7	298.5	203.2	63.5	304.8	393.7	12	38.1
10	546	323.9	368.3	254.0	69.9	406.4	469.9	16	38.1
12	610	381.0	419.1	304.8	79.2	406.4	533.4	20	38.1
14	641	412.8	450.9	355.6	85.9	To be specified by Purchaser.	558.8	20	41.1
16	705	469.9	508.0	406.4	88.9		616.0	20	44.5
18	787	533.4	565.2	457.2	101.6		685.8	20	50.8
20	857	584.2	622.3	508.0	108.0		749.3	20	53.8
24	1041	692.2	749.3	609.6	139.7		901.7	20	66.5

Use Class 1500 dimensions in these sizes.

**CLASS 1500 FLANGES**

Unit : mm

Nominal Pipe Size	Outside Diam.	O.D of Raised Face	Hub Diameter of Bevel	Diameter of Bore	Thickness of Flange Min	Length Thru Hub	DRILLING		
							Diameter of Bolt Circle	Number of Holes	Diameter of Holes
	D	G	E	B	t	L	C		d
1	149	50.8	52.4	25.4	28.4	228.6	101.6	4	25.4
1 1/4	159	63.5	63.5	31.8	28.4	228.6	111.3	4	25.4
1 1/2	178	73.2	69.9	38.1	31.8	228.6	124.0	4	28.4
2	216	91.9	104.6	50.8	38.1	228.6	165.1	8	25.4
2 1/2	244	104.6	124.0	63.5	41.1	304.8	190.5	8	28.4
3	267	127.0	133.4	76.2	47.8	304.8	203.2	8	31.8
4	311	157.2	162.1	101.6	53.8	304.8	241.3	8	35.1
5	375	185.7	196.9	127.0	73.2	304.8	292.1	8	41.1
6	394	215.9	228.6	152.4	82.6	304.8	317.5	12	38.1
8	483	269.7	292.1	203.2	91.9	304.8	393.7	12	44.5
10	584	323.9	368.3	254.0	108.0	406.4	482.6	12	50.8
12	673	381.0	450.9	304.8	124.0	406.4	571.5	16	53.8
14	749	412.8	495.3	355.6	133.4	To be specified by Purchaser.	635.0	16	60.5
16	826	469.9	552.5	406.4	146.1		704.9	16	66.5
18	914	533.4	596.9	457.2	162.1		774.7	16	73.2
20	984	584.2	641.4	508.0	177.8		831.9	16	79.2
24	1168	692.2	762.0	609.6	203.2		990.6	16	91.9

NOTE : 1. Bore (B) is the same as nominal pipe size.  
2. Welding necks longer than listed are available in all sizes on special order.

**CLASS 2500 FLANGES**

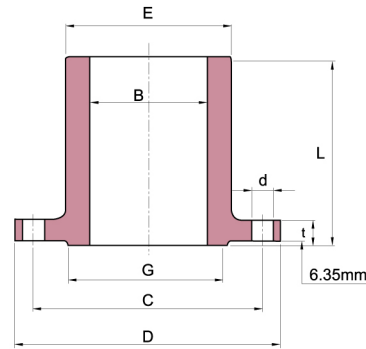

Unit : mm

Nominal Pipe Size	Outside Diam.	O.D of Raised Face	Hub Diameter of Bevel	Diameter of Bore	Thickness of Flange Min	Length Thru Hub	DRILLING		
							Diameter of Bolt Circle	Number of Holes	Diameter of Holes
	D	G	E	B	t	L	C		d
1	159	50.8	57.2	25.4	35.1	228.6	108.0	4	25.4
1 1/4	184	63.5	73.2	31.8	38.1	228.6	130.0	4	28.4
1 1/2	203	73.2	79.2	38.1	44.5	228.6	146.1	4	31.8
2	235	91.9	95.3	50.8	50.8	228.6	171.5	8	28.4
2 1/2	267	104.6	114.3	63.5	57.2	304.8	196.9	8	31.8
3	305	127.0	133.4	76.2	66.5	304.8	228.6	8	35.1
4	356	157.2	165.1	101.6	76.2	304.8	273.1	8	41.1
5	419	185.7	203.2	127.0	91.9	304.8	323.9	8	47.8
6	483	215.9	235.0	152.4	108.0	304.8	368.3	8	53.8
8	552	269.7	304.8	203.2	127.0	304.8	438.2	12	53.8
10	673	323.9	374.7	254.0	165.1	406.4	539.8	12	66.5
12	762	381.0	441.5	304.8	184.2	406.4	619.3	16	73.2

**GUIDE TO MATERIAL LAYOUT & SPECIFICATIONS**

Pipe	Weld Fittings	Screwed & Scket Fittings	Flanges	Valves
A-53	A-234 WPB	A-105, A-181 Gr. 60 or 70	A-105, A-181 Gr. 60 or 70	A-105 A-216 WCB
A-106B	A-234 WPB	A-105, Gr. 60 or 70	A-105, Gr. 60 or 70	A-105 A-216 WCB
A-312 T304	A-403 WP-304	A-182 F-304	A-182 F-304	A-182 F-304 CMO
A-312 T316	A-403 WP-316	A-182 F-316	A-182 F-316	A-182 F-316 CM 8MO
A-333 Gr. 1or6	A-420 WPL 1&6	A-350 LF-1	A-350 LF-1	A-350 LF-1 A-352 LCB
A-333 Gr. 3	A-420 WPL-3	A-350 LF-3	A-350 LF-3	A-350 LF-3 A-352 LC3
A-335 P-1	A-234 WP-1	A-182 F-1	A-182 F-1	A-217 WC-6
A-335 P-11	A-234 WP-11	A-182 F-11	A-182 F-11	A-182 F-11 A-217 WC-6
A-335 P-12	A-234 WP-12	A-182 F-12	A-182 F-12	A-217 WC-6
A-335 P-22	A-234 WP-22	A-182 F-22	A-182 F-22	A-182 F-22 A-217 WC-9
A-335 P-5	A-234 WP-5	A-182 F-5	A-182 F-5	A-182 F-5 A-216 WC-5
A-335 P-7	A-234 WP-7	A-182 F-7	A-182 F-7	A-182 F-7 A-217 WC-12
A-335 P-9	A-234 WP-9	A-182 F-9	A-182 F-9	A-182 F-9 A-217 WC-12

NOTE : 1. Bore (B) is the same as nominal pipe size.  
2. Welding necks longer than listed are available in all sizes on special order.

## REDUCING FLANGES

### Threaded and Slip-on Types

#### ■ HUB

For hub diameter (X) and height of hub above the back of the flange (N) refer to the list of standard flange specification of the same type and pressure and use the dimensions of a flange one nominal pipe size smaller than the nominal pipe size from which the reduction is being made.

#### ■ FLANGE O.D., DRILLING TEMPLATE AND THICKNESS

Outside diameter, drilling template and flange thickness Q (See note on FACINGS) agree with the dimensions of a standard flange of the nominal pipe size from which the reduction is being made.

#### ■ FACING

Facing dimensions also agree with the dimensions of a standard flange of the nominal pipe size from which the reduction is being made.

150 lb. and 300 lb. forged steel Threaded, Slip-On, Welding Neck and Blind flanges are furnished with American Standard 1/16" raised face which is included in flange thickness. Q. 400 lb., 600 lb., 900 lb., 1500 lb., 1500 lb. and 2500 lb. flange are supplied with American Standard 1/4" raised face which is not included in flange thickness (Q)

#### ■ BORE OR TAPPING

The bore or tapping is machined to accept a pipe of the nominal pipe size to which the reduction is being made. For reduction to size smaller than shown, BLIND FLANGE are tapped or bored to specified nominal pipe size.

#### EXAMPLE :

A 300 lb. threaded flange used in reducing from a 6" (152.4mm) to 3" (76.2mm) nominal pipe size should be specified as a 3" (76.2mm) x 12 1/2" - 300 lb. Threaded Reducing Flange. It would have the following dimensional characteristics :

Diameter of Hub (X) - 7" (177.8mm).

Height of Hub (N) - 5/8".

Hub dimensions are those of a 5" (127.0mm), 300lb, Standard flange.

Outside Diameter - 12 1/2"

Thickness (Q) - 1 7/16"

Raised face - 1/16".

O.D., Flange Thickness Q., Raised Face and Drilling Template are those of a 6" (152.4mm), 300lb. Standard Flange.

Tapping - 3" (76.2mm) I.P.S.

Flange is tapped to the nominal pipe size to which reduction is being made.

#### WELDING NECK TYPES

On Reducing Welding Neck Flanges. which are made only on special order, the hub dimensions agree with the hub dimensions of standard flanges of the size to which reduction is being made. Other flange dimensions, including the drilling template, agree with the standard dimensions of the size from which the reduction is being made.

# REDUCING FLANGES

Threaded-Slip-on-Welding neck

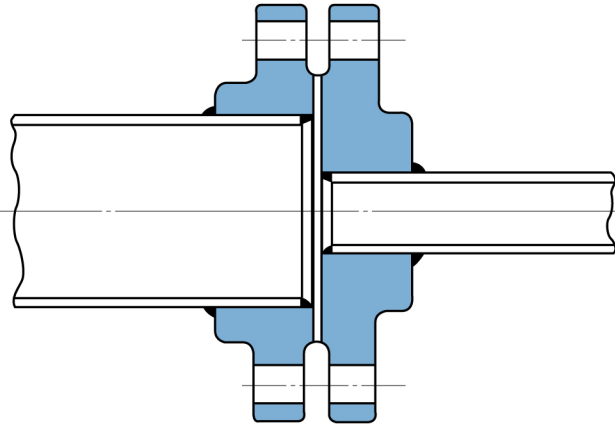

In ordering Reducing Flanges : specify (1) nominal pipe size of the tapping or bore to which the reduction is being made.  
 (2) the outside diameter of the flange from which the reduction is being made and (3) pressure rating.

**EXAMPLE :**

A 300 lb. Reducing flange for reducing from a 6" (152.4mm) to a 3" (76.2mm) nominal pipe size should be designated as a 3" (76.2mm) x 12 1/2" - 300 lb. Reducing Flange. Whether Threaded, Slip-On, or Welding Neck type is desired must also be specified.

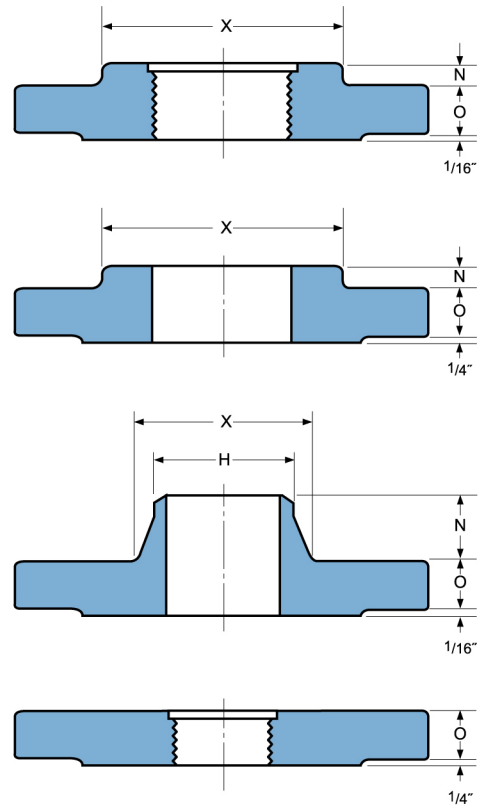

## ANSI B 16.5 Forged Flanges

Dimensions inches.

Nominal Flange	OUTSIDE DIAMETER OF FLANGE FROM WHICH REDUCTION IS BEING MADE							Smallest Size Bore or Tapping Requiring Hub Flange
	150 lb. Standard	300 lb. Standard	400 lb. Standard	600 lb. Standard	900 lb. Standard	1500 lb. Standard	2500 lb. Standard	
3/4	3 7/8	4 5/8	4 5/8	4 5/8	5 1/8	5 1/8	5 1/2	1/2
1	4 1/4	4 7/8	4 7/8	4 7/8	5 7/8	5 7/8	6 1/4	1/2
1 1/4	4 5/8	5 1/4	5 1/4	5 1/4	6 1/4	6 1/4	7 1/4	1/2
1 1/2	5	6 1/8	6 1/8	6 1/8	7	7	8	1/2
2	6	6 1/2	6 1/2	6 1/2	8 1/2	8 1/2	9 1/4	1
2 1/2	7	7 1/2	7 1/2	7 1/2	9 5/8	9 5/8	10 1/2	1 1/4
3	7 1/2	8 1/4	8 1/4	8 1/4	9 1/2	10 1/2	12	1 1/4
3 1/2	8 1/2	9	9	9	-	-	-	1 1/2
4	9	10	10	10 3/4	11 1/2	12 1/4	14	1 1/2
5	10	11	11	13	13 3/4	14 3/4	16 1/2	1 1/2
6	11	12 1/2	12 1/2	14	15	15 1/2	19	2 1/2
8	13 1/2	15	15	16 1/2	18 1/2	19	21 3/4	3
10	16	17 1/2	17 1/2	20	21 1/2	23	26 1/2	3 1/2
12	19	20 1/2	20 1/2	22	24	26 1/2	30	3 1/2
14	21	23	23	23 3/4	25 1/4	-	-	3 1/2
16	23 1/2	25 1/2	25 1/2	27	27 3/4	-	-	4
18	25	28	28	29 1/4	31	-	-	4
20	27 1/2	30 1/2	30 1/2	32	33 3/4	-	-	4
24	32	36	36	37	41	-	-	4

NOTE :  
 For reductions to size smaller than shown, blind flange are tapped or bored for specified nominal pipe size.

# STANDARD FINISH

## Standard Finishes for Face of Flange(ANSI B16.5)

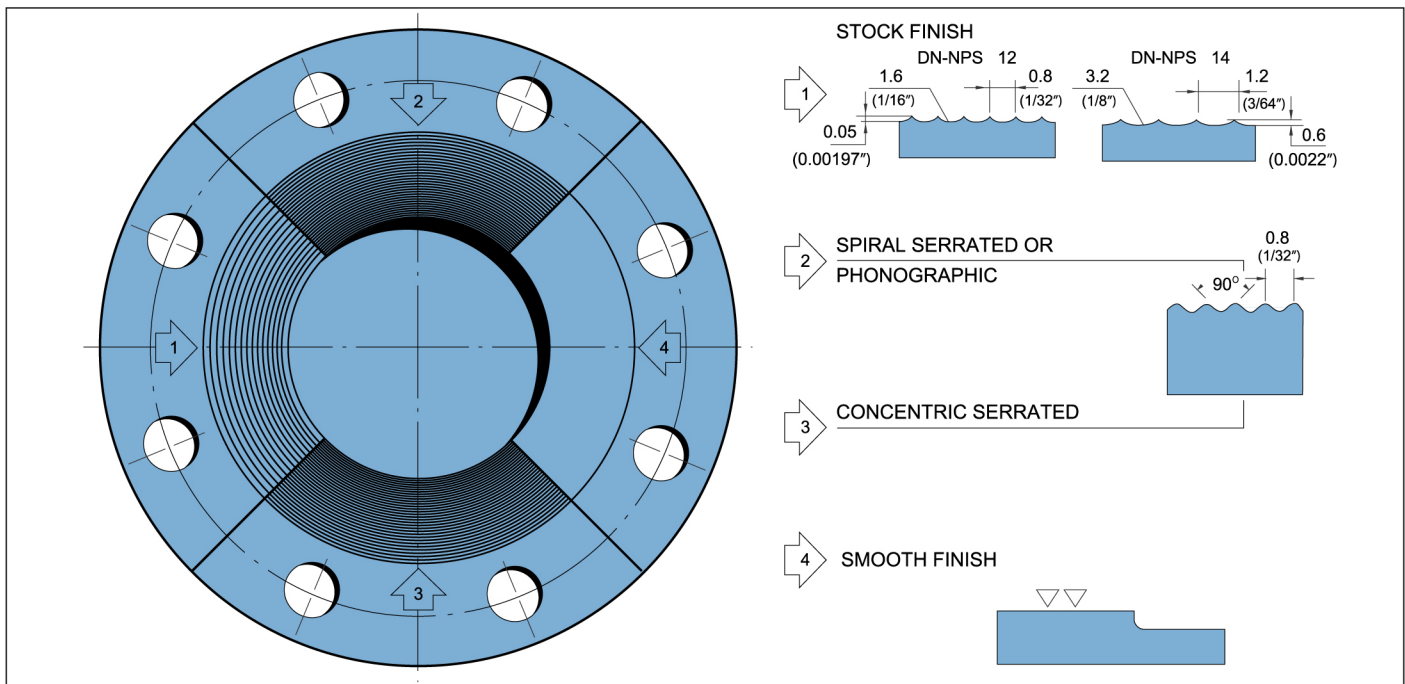

**STOCK FINISH :** The most widely used of any gasket finish, because, practically, is suitable for all ordinary service conditions. This is a continuous spiral groove. Flanges sizes 12” (304.8mm) and smaller, are produced with a 1/16” round nosed tool at a feed of 1/32” per revolution. For sizes 14” (355.6mm) and larger, the finish is made with 1/8” round-nosed tool at a feed of 3/64” per revolution.

**SPIRAL SERRATED OR PHONOGRAPHIC :** This finish is produced by using a 90° round nosed tool.

**CONCENTRIC SERRATED :** This finish is produced by using a 90° round nosed tool.

**SMOOTH FINISH :** The cutting tool employed shall have an approximate 0.06” radius. The resultant surface finish shall have a 125 μ inch to 250 μ inch (ANSI B 16.5 para 6, 4, 4)

■ **RAISED FACE, AND LARGE MALE AND FEMALE**

Either a serrated-concentric or serrated-spiral finish having from 45 to 55 grooves per inch is used. The cutting tool employed has an approximate 0.06 in, radius. The resultant surface finish shall have a 125 μ inch (3.2μm), to 250 μ inch (6.4μm) approximate roughness.

■ **TONGUE AND GROOVE, AND SMALL MALE AND FEMALE**

The gasket contact surface does not exceed 125 μ in (3.2μm) roughness.

■ **RING JOINT**

The inside wall surface of gasket groove does not exceed 63 μ in (1.6μm) roughness.

■ **BLIND**

Blind flanges need not be faced in the center if, when this center part is raised, its diameter is at least 1 in smaller than the inside diameter of fittings of the corresponding pressure class. When the center part is depressed, its diameter is not greater than the inside diameter of the corresponding pressure class fittings. Maching of the depressed center is not required.



# TOLERANCE

## ANSI B16.5 Forged Flanges

SOLID FANAGE

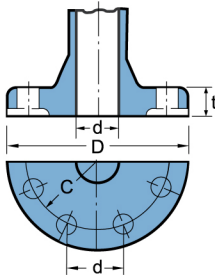

SLIP-ON FLANGE

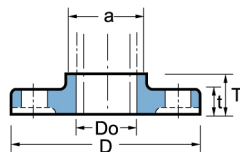

WELDING NECK FLANGE

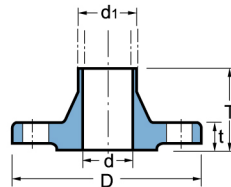

TYPE OF GASKET SURFACE

MALE & FEMALE TYPE

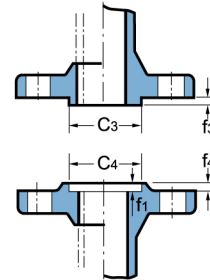

TONGUE & GROOVE TYPE

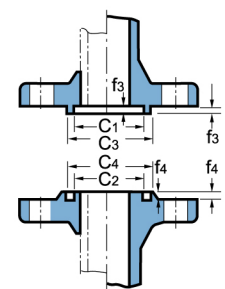

### THREADED, SOCKET-WELDING, SLIP-ON, LAP JOINT AND BLIND

Outside Diameter	When O.D. is 24" or less	±1 1/16" (1.6mm)*
	When O.D. is Over 24"	±1/8" (3.2mm)*
Inside Diameter	Threaded	Within limits on boring gauge
	Socket-Welding, Slip-on and Lap joint	10" & Smaller +1/32" (0.8mm), -0" 12" & Larger +1/16" (1.6mm), -0"
Outside Diameter of Hub	5" and Smaller	+3/32" (2.4mm)* -1/32" (0.8mm)
	6" and Larger	+5/32" (4.0mm) -1/32" (0.8mm)
Diameter of Contact Face	1/16" Raised Face	+1/32" (0.8mm)
	1/4" Raised Face Tongue & Groove Male, Female	+1/64" (0.4mm)
Diameter of Counterbore	Same as for Inside Diameter	
Drilling	Bolt Circle	±1/16" (1.6mm)
	Bolt Hole Spacing	±1/32" (0.8mm)
	Eccentricity of Bolt Circle with Respect to Facing	2 1/2" & Smaller 1/32" (0.8mm) Max. 3" & Larger 1/16" (1.6mm) Max.
	Eccentricity of Bolt Circle with Respect to Bore	1/32" (0.8mm) Max.*
Thickness	18" and Smaller	+1/8" (3.2mm), -0"
	20" and Larger	+3/16" (4.8mm), -0"
Length Thru Hub	10" and Smaller	±1/16" (1.6mm)
	12" and Larger	±1/8" (3.2mm)

NOTE : \* This tolerance is not covered in ANSI B16.5, but maker's option

### WELDING NECK

Outside Diameter	When O.D. is 24" or less	±1 1/16" (1.6mm)*
	When O.D. is Over 24"	±1/8" (3.2mm)*
Inside Diameter	10" and Smaller	±1/32" (0.8mm)
	12" thru 18"	±1/16" (1.6mm)
	20" and Larger	+1/8" (3.2mm) -1/16" (1.6mm)
Diameter of Contact Face	1/16" Raised Face	±1/32" (0.8mm)
	1/4" Raised Face Tongue & Groove Male, Female	+1/64" (0.4mm)
Diameter of Hub at Base	When Hub Base is 24" or Smaller	±1/16" (1.6mm)
	When Hub Base is Over 24"	±1/8" (3.2mm)
Diameter of Hub at Point of Welding	5" and Smaller	+3/32" (2.4mm) -1/32" (0.8mm)
	6" and Larger	+5/32" (4.0mm) -1/32" (0.8mm)
Drilling	Bolt Circle	±1/16" (1.6mm)
	Bolt Hole Spacing	±1/32" (0.8mm)
	Eccentricity of Bolt Circle with Respect to Facing	2 1/2" & Smaller 1/32" (0.8mm) Max. 3" & Larger 1/16" (1.6mm) Max.
	Eccentricity of Bolt Circle with Respect to Bore	1/32" (0.8mm) Max.*
Thickness	18" and Smaller	+1/8" (3.2mm), -0"
	20" and Larger	+3/16" (4.8mm), -0"
Length Thru Hub	4" and Smaller	±1/16" (1.6mm)
	5" ~ 10"	+1.6 ~ 3.0mm
	12" and Larger	+3.0 ~ 5.0mm

NOTE : \* This tolerance is not covered in ANSI B16.5, but maker's option

# THREAD

## Thread and Standards for ANSI Flanges (ANSI B2.1)

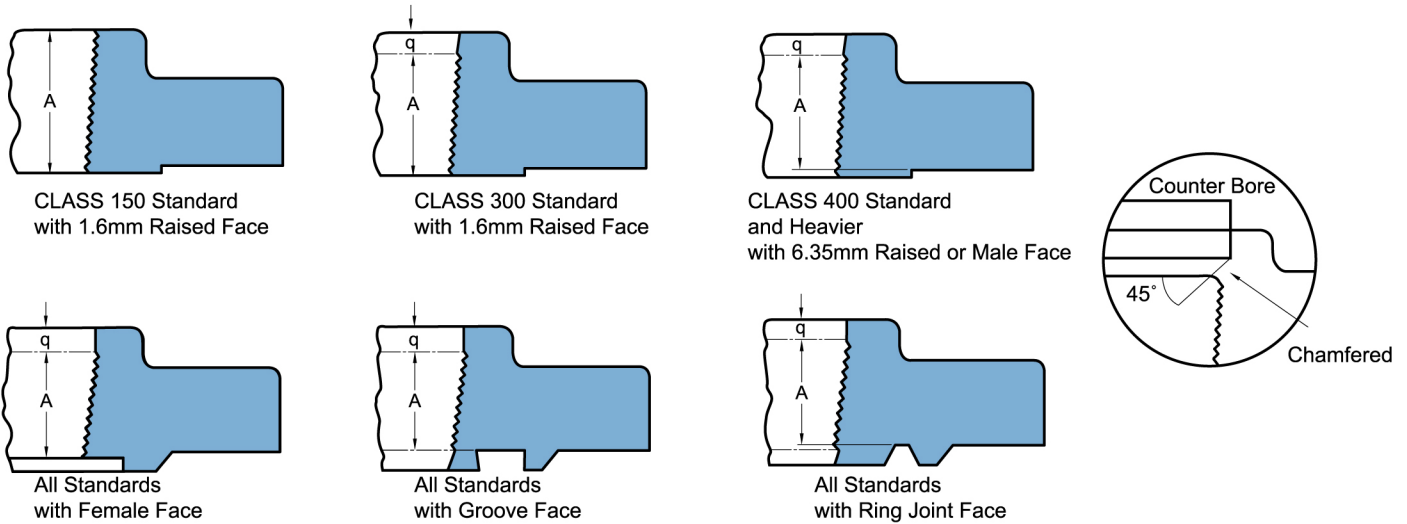

## ANSI B 16.5 Forged Flanges

Unit : mm

Nominal Pipe Size	A-THREAD LENGTHS						
	Class 150	Class 300	Class 400	Class 600	Class 900	Class 1500	Class 2500
1/2	15.9	15.9	15.9	15.9	22.2	22.2	28.6
3/4	15.9	15.9	15.9	15.9	25.4	25.4	31.8
1	17.5	17.5	17.5	17.5	28.6	28.6	34.9
1 1/4	20.7	20.7	20.7	20.7	30.2	30.2	38.1
1 1/2	22.2	22.2	22.2	22.2	31.8	31.8	44.5
2	25.4	28.6	28.6	28.6	38.1	38.1	50.8
2 1/2	28.6	31.8	31.8	31.8	47.6	47.6	57.2
3	30.1	31.8	34.9	34.9	41.3	50.8	63.5
3 1/2	31.8	36.5	39.7	39.7	-	-	-
4	33.4	36.5	36.5	41.3	47.6	57.2	69.9
5	36.5	42.9	42.9	47.6	54.0	63.5	76.2
6	39.7	46.1	46.1	50.8	57.2	69.9	82.6
8	44.5	50.8	50.8	60.3	63.5	76.2	95.3
10	49.2	55.6	55.6	65.1	71.5	84.2	108.0
12	55.6	60.3	60.3	69.9	76.2	92.1	120.7
14	57.2	63.5	63.5	73.0	82.6	-	-
16	63.5	68.3	68.3	77.8	85.7	-	-
18	68.3	69.9	69.9	79.4	88.9	-	-
20	69.9	73.0	73.0	82.6	92.1	-	-
24	82.6	82.6	82.6	92.1	101.6	-	-

**NOTE :**

1. Except flanges with Small Male / Female face (on pipe end), threaded flanges, have an American National Standard taper pipe thread conforming to ANSI B2.1
2. The thread is concentric with the axis of the flange and variations in alignment do not exceed 0.06"(1.6mm)in, per foot (05. percent).
3. Class 150 flanges are made without counterbore. The threads are chamfered approximately to the major diameter of the thread at the back of the flange at an angle of approximately 45 degrees with the axis of the thread. The chamfer is concentric with the thread and included in the measurement of the thread length.
4. Class 300 and higher pressure flanges are made with a counterbore at the back of the flange. The threads are chamfered to the diameter of the counterbore at an angle of approximately 45 degrees with the axis of the thread. The counterbore and chamfer are concentric with the thread.
5. The minimum length of effective thread in reducing flanges is at least equal to dimension Q of the corresponding class of threaded flange as shown in the above table. Threads do not necessarily extend to the face to the flange.

# WELDING ENDS

## ANSI B16.5 Forged Flanges

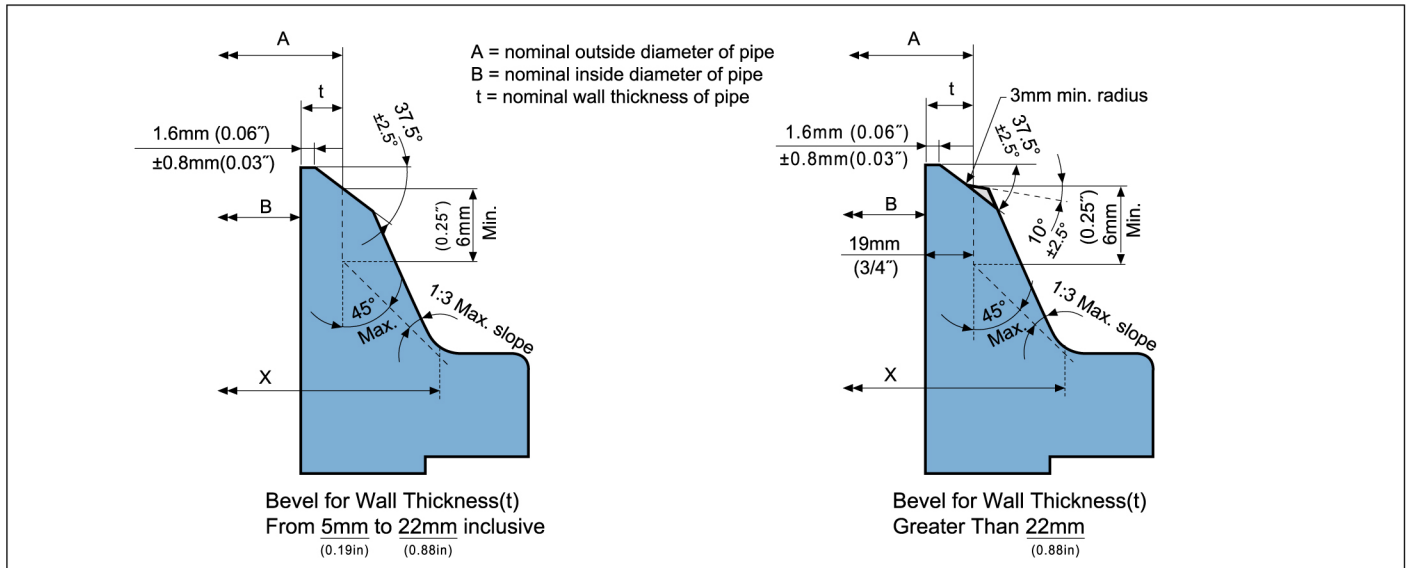

**Notes :**

When the thickness of the hub at the bevel is greater than that of the pipe to which the flange is joined and the additional thickness is provided on the outside diameter, a taper weld having a slope not exceeding 1 to 3 may be employed or, alternatively, the greater outside diameter may be tapered, at the same maximum slope or less, from a point on the welding bevel equal to the O.D. at the mating pipe. Similarly, when the greater thickness is provided on the inside of the flange, it shall be taper-bored from the welding end at a slope not exceeding 1 to 3

When flanges covered by this standard are intended for services with light wall, higher strength pipe, the thickness of the hub at the bevel may be greater than that of the pipe to which the flange is joined. Under these conditions a single taper hub may be provided and the outside diameter of the hub at the base (Dimension X) may also be modified.

The additional thickness may be provided on either inside or outside or partially on each side, but the total additional thickness shall not exceed one-half times the nominal wall thickness of intended mating pipe

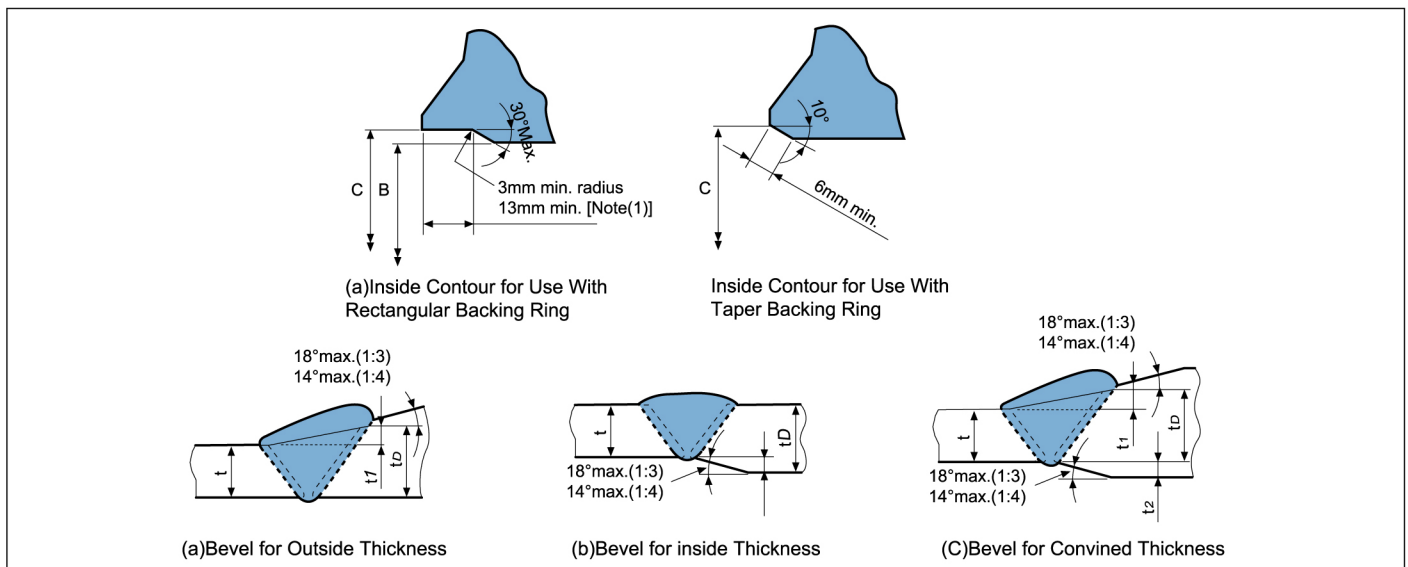

**Notes :**

- (1) When the materials joined have equal minimum specified yield strength, there shall be no restriction on the minimum slope.
- (2) Neither t1, t2, t3 nor their sum (t1 + t2) shall exceed 0.5t
- (3) When the minimum specified yield strengths of the sections to be joined are unequal, the value of t shall at least equal t time the ratio of minimum specified yield strength of the pipe to minimum specified yield strength of the flange.

# PIPE&FITTINGS WALL THICKNESS SCHEDULES DIMENSION

Nominal Pipe Size		Outside Diam.	Wall I.D.	Nominal Wall Thickness (Stainless steel)					Nominal Wall Thickness (Carbon & Low Alloy Steel)			
A	B			S5S*	S10S*	S20S	S40S	S80S	S5	S10	S20	S30
6	1/8	10.3	W.T	-	1.24	-	1.73	2.41	-	1.24	-	1.45
			I.D	-	7.82	-	6.84	5.48	-	7.82	-	7.40
8	1/4	13.7	W.T	-	1.65	-	2.24	3.02	-	1.65	-	1.85
			I.D	-	10.40	-	9.22	7.66	-	10.40	-	10.00
10	3/8	17.1	W.T	-	1.65	-	2.31	3.20	-	1.65	-	1.85
			I.D	-	13.80	-	12.48	10.70	-	13.80	-	13.40
15	1/2	21.3	W.T	1.65	2.11	-	2.77	3.73	1.65	2.11	-	2.41
			I.D	18.00	17.08	-	15.76	13.84	18.00	17.08	-	16.48
20	3/4	26.7	W.T	1.65	2.11	-	2.87	3.91	1.65	2.11	-	2.41
			I.D	23.40	22.48	-	20.96	18.88	23.40	22.48	-	21.88
25	1	33.4	W.T	1.65	2.77	-	3.38	4.55	1.65	2.77	-	2.90
			I.D	30.10	27.86	-	26.64	24.30	30.10	27.86	-	27.60
32	1 1/4	42.2	W.T	1.65	2.77	-	3.56	4.85	1.65	2.77	-	2.97
			I.D	38.90	36.66	-	35.08	32.50	38.90	36.66	-	36.26
40	1 1/2	48.3	W.T	1.65	2.77	-	3.68	5.08	1.65	2.77	-	3.18
			I.D	45.00	42.76	-	40.94	38.14	45.00	42.76	-	41.94
50	2	60.3	W.T	1.65	2.77	-	3.91	5.54	1.65	2.77	-	3.18
			I.D	57.00	54.76	-	52.48	49.22	57.00	54.76	-	53.94
65	2 1/2	73.0	W.T	2.11	3.05	-	5.16	7.01	2.11	3.05	-	4.78
			I.D	68.78	66.90	-	62.68	58.98	68.78	66.90	-	63.44
80	3	88.9	W.T	2.11	3.05	-	5.49	7.62	2.11	3.05	-	4.78
			I.D	84.68	82.80	-	77.92	73.66	84.68	82.80	-	79.34
90	3 1/2	101.6	W.T	2.11	3.05	-	5.74	8.08	2.11	3.05	-	4.78
			I.D	97.38	95.50	-	90.12	85.44	97.38	95.50	-	92.04
100	4	114.3	W.T	2.11	3.05	-	6.02	8.56	2.11	3.05	-	4.78
			I.D	110.08	108.20	-	102.26	97.18	110.08	108.20	-	104.74
125	5	141.3	W.T	2.77	3.40	-	6.55	9.53	2.77	3.40	-	-
			I.D	135.76	134.50	-	128.20	122.24	135.76	134.50	-	-
150	6	168.3	W.T	2.77	3.40	-	7.11	10.97	2.77	3.40	-	-
			I.D	162.76	161.50	-	154.08	146.36	162.76	161.50	-	-
200	8	219.1	W.T	2.77	3.76	-	8.18	12.70	2.77	3.76	6.35	7.04
			I.D	213.56	211.58	-	202.74	193.70	213.56	211.58	20.640	205.02
250	10	273.1	W.T	3.40	4.19	-	9.27	12.70	3.40	4.19	6.35	7.80
			I.D	266.30	264.72	-	254.56	247.70	266.30	264.72	260.40	257.50
300	12	323.9	W.T	3.96	4.57	-	9.53	12.70	3.96	4.57	6.35	8.38
			I.D	315.98	314.76	-	304.84	298.50	315.98	314.76	311.20	307.14
350	14	355.6	W.T	3.96	4.78	-	9.53	12.70	3.96	6.35	7.92	9.53
			I.D	347.68	346.04	-	336.54	330.20	347.68	342.90	339.76	336.54
400	16	406.4	W.T	4.19	4.78	-	9.53	12.70	4.19	6.35	7.92	9.53
			I.D	398.02	396.84	-	387.34	381.00	398.02	393.70	390.56	387.34
450	18	457.0	W.T	4.19	4.78	-	9.53	12.70	4.19	6.35	7.92	11.13
			I.D	448.62	447.44	-	437.94	431.60	448.62	444.30	441.16	434.74
500	20	508.0	W.T	4.78	5.54	7.90	9.53	12.70	4.78	6.35	9.53	12.70
			I.D	498.44	496.62	492.20	488.94	482.60	498.44	495.30	488.94	482.60
550	22	559.0	W.T	4.78	5.54	-	-	-	4.78	6.35	9.53	12.70
			I.D	549.44	547.92	-	-	-	549.44	546.30	539.34	533.60
600	24	610.0	W.T	5.54	6.35	-	9.53	12.70	5.54	6.35	9.53	14.27
			I.D	598.92	597.30	-	590.94	584.60	598.92	597.30	590.94	581.46

• Carbon & Low Alloy Steel (B36.10M)

The wall thickness shown represent nominal or average wall dimensions which are subject to a-12 1/2% mill tolerance.

Note that schedule 40 in. size 12" (304.8mm) and larger and that schedule 80 in. size 10" (254mm) and larger do not agree with schedules 40S and 80S of ANSI B36.19 nor with standard weight and extra strong respectively.

# ASME B36.10M & ASME B36.19M - 2004

-Nominal Wall Thickness (Carbon & Low Alloy Steel)-										Outside Diam.	Nominal Pipe Size	
STD	S40	S60	XS	S80	S100	S120	S140	S160	XXS		A	B
1.73	1.73	-	2.41	2.41	-	-	-	-	-	10.3	6	1/8
6.84	6.84	-	5.48	5.48	-	-	-	-	-			
2.24	2.24	-	3.02	3.02	-	-	-	-	-	13.7	8	1/4
9.22	9.22	-	7.66	7.66	-	-	-	-	-			
2.31	2.31	-	3.20	3.20	-	-	-	-	-	17.1	10	3/8
12.48	12.48	-	10.70	10.70	-	-	-	-	-			
2.77	2.77	-	3.73	3.73	-	-	-	4.78	7.47	21.3	15	1/2
15.76	15.76	-	13.84	13.84	-	-	-	11.74	6.36			
2.87	2.87	-	3.91	3.91	-	-	-	5.56	7.82	26.7	20	3/4
20.96	20.96	-	18.88	18.88	-	-	-	15.58	11.06			
3.38	3.38	-	4.55	4.55	-	-	-	6.35	9.09	33.4	25	1
26.64	26.64	-	24.30	24.30	-	-	-	20.70	15.22			
3.56	3.56	-	4.85	4.85	-	-	-	6.35	9.70	42.2	32	1 1/4
35.08	35.08	-	32.50	32.50	-	-	-	29.50	22.80			
3.68	3.68	-	5.08	5.08	-	-	-	7.14	10.15	48.3	40	1 1/2
40.94	40.94	-	38.14	38.14	-	-	-	34.02	28.00			
3.91	3.91	-	5.54	5.54	-	-	-	8.74	11.07	60.3	50	2
52.46	52.48	-	49.22	49.22	-	-	-	42.82	38.16			
5.16	5.16	-	7.01	7.01	-	-	-	9.53	14.02	73.0	65	2 1/2
62.68	62.68	-	58.98	58.98	-	-	-	53.94	44.96			
5.49	5.49	-	7.62	7.62	-	-	-	11.13	15.24	88.9	80	3
77.92	77.92	-	73.66	73.66	-	-	-	66.64	58.24			
5.74	5.74	-	8.08	8.08	-	-	-	12.70	-	101.6	90	3 1/2
90.12	90.12	-	85.44	85.44	-	-	-	76.20	-			
6.02	6.02	-	8.56	8.56	-	11.13	-	13.49	17.12	114.3	100	4
102.26	102.26	-	97.18	97.18	-	92.04	-	87.32	80.06			
6.55	6.55	-	9.53	9.53	-	12.70	-	15.88	19.05	141.3	125	5
128.20	128.20	-	122.24	122.24	-	115.90	-	109.54	103.20			
7.11	7.11	-	10.97	10.97	-	14.27	-	18.26	21.95	168.3	150	6
154.08	154.08	-	146.36	146.36	-	139.76	-	131.78	124.40			
8.18	8.18	10.31	12.70	12.70	15.09	18.26	20.62	23.01	22.23	219.1	200	8
202.74	202.74	198.48	193.70	193.70	188.92	182.58	177.86	173.08	174.63			
9.27	9.27	12.70	12.70	15.09	18.26	21.44	25.40	28.58	25.40	273.1	250	10
254.56	254.56	247.70	247.70	242.92	236.58	230.22	222.30	215.94	222.30			
9.53	10.31	14.27	12.70	17.48	21.44	25.40	28.58	33.32	25.40	323.9	300	12
304.84	303.28	295.36	298.50	288.94	281.02	273.10	266.74	257.26	273.10			
9.53	11.13	15.09	12.70	19.05	23.83	27.79	31.75	35.71	-	355.6	350	14
336.54	333.34	325.42	330.20	317.50	307.94	300.02	292.10	284.18	-			
9.53	12.70	16.66	12.70	21.44	26.19	30.96	36.53	40.49	-	406.4	400	16
387.34	381.00	373.08	381.00	363.52	354.02	344.48	333.34	325.42	-			
9.53	14.27	19.05	12.70	23.83	29.36	34.93	39.67	45.24	-	457.0	450	18
437.94	428.46	418.90	431.60	409.34	398.28	387.14	377.66	366.52	-			
9.53	15.09	20.62	12.70	26.19	32.54	38.10	44.45	50.01	-	508.0	500	20
488.94	477.82	466.76	482.60	455.62	442.92	431.80	419.10	407.98	-			
9.53	-	22.23	12.70	28.58	34.93	41.28	47.63	53.98	-	559.0	550	22
539.94	-	514.54	533.60	501.84	489.14	476.44	463.74	451.04	-			
9.53	17.48	24.61	12.70	30.96	38.89	46.02	52.37	59.54	-	610.0	600	24
590.94	575.04	560.78	584.60	548.08	532.22	517.96	505.26	490.92	-			

● **Stainless steel (B36.19M)**

The wall thickness shown represent nominal or average wall dimensions which are subject to a-12 1/2% mill tolerance.

+Size 14"(355.6mm) through 30"(762.0mm) are not at publication data covered in B36.19, and dimensions listed are those commonly used in the industry.

\*Schedules 5S and 10S wall thicknesses do not permit threading in accordance with ASME B2 1.

\*\*Note that schedule 40S and schedule 80S in these sizes do not agree with schedule 40 and schedule 80 of ASME B36.10, and that they are identical to standard weight and extra strong respectively of ASME B36.10.