

# Flanges



# Contents

## ANSI B16.5 FLANGES

Class 150 Flanges .....	4~5
Class 300 Flanges .....	6~7
Class 400 Flanges .....	8~9
Class 600 Flanges .....	10~11
Class 900 Flanges .....	12~13
Class 1500 Flanges .....	14~15
Class 2500 Flanges .....	16~17

## RING JOINT FLANGES

Class 150 Flanges .....	19
Class 300/400/600 Flanges .....	20
Class 900 Flanges .....	21
Class 1500 Flanges .....	22
Class 2500 Flanges .....	23

## ORIFICE FLANGES

ANSI ORIFICE Flanges .....	25
Class 300 Flanges .....	26~27
Class 400 Flanges .....	28~29
Class 600 Flanges .....	30~31
Class 900/1500 Flanges .....	32~33
Class 2500 Flanges .....	34

## LONG WELDING NECK FLANGES

Class 150 Long Welding Necks .....	36
Class 400 Long Welding Necks .....	37
Class 900/1500 Long Welding Necks .....	38
Class 2500 Long Welding Necks .....	39
Reducing Flanges .....	40~41
Stand Finish .....	42
Tolerance .....	43
Thread .....	44
Welding Ends .....	45
Pipe&Fittings wall thickness schedules dimension .....	46~47

## JIS/KS FLANGES

Class 5K Flanges .....	49
Class 10K Flanges .....	50
Class 16K Flanges .....	51
Class 20K Flanges .....	52
Class 30K Flanges .....	53
210Kgf/cm <sup>2</sup> JIS B2291 Square Flanges .....	54
Tolerance for Pipe Flanges .....	55





# ANSI FLANGES

- Class 150 Flanges
- Class 300 Flanges
- Class 400 Flanges
- Class 600 Flanges
- Class 900 Flanges
- Class 1500 Flanges
- Class 2500 Flanges

# CLASS 150 FLANGES

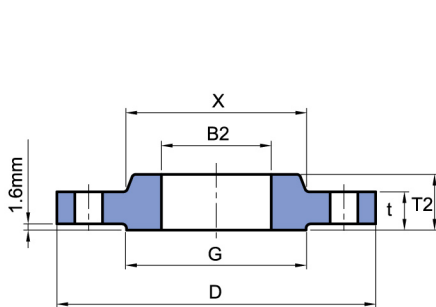

SLIP-ON

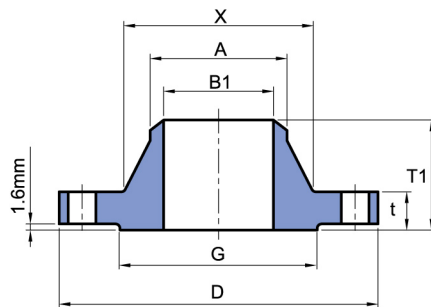

WELDING NECK

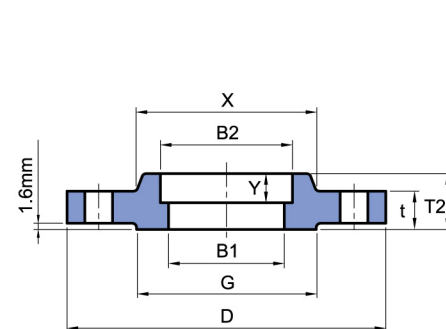

SOCKET WELDING

## ANSI B 16.5 Forged Flanges

Unit : mm

Nominal Pipe Size	Outside Diam.	Diam. at Base of Hub	O.D of Raised Face	Thickness	BORE			LENGTH THRU HUB			Diam. of Hub at Bevel	Radius of Fillet	Thread Length	Depth of Socket
					Welding Neck Socket Welding	Slip-on Socket Welding	Lap Joint	Welding Neck	Slip-on Threaded Socket Welding	Lap Joint				
					B1	B2	B3	T1	T2	T3				
1/2	89	30.2	35.1	11.2	15.8	22.4	22.9	47.8	15.7	15.7	21.3	3.0	15.7	9.7
3/4	99	38.1	42.9	12.7	20.8	27.7	28.2	52.3	15.7	15.7	26.7	3.0	15.7	11.2
1	108	49.3	50.8	14.2	26.7	34.5	35.1	55.6	17.5	17.5	33.5	3.0	17.5	12.7
1 1/4	117	58.7	63.5	15.7	35.1	43.2	43.7	57.2	20.6	20.6	42.2	4.8	20.6	14.2
1 1/2	127	65.0	73.2	17.5	40.9	49.5	50.0	62.0	22.4	22.4	48.3	6.4	22.4	15.8
2	152	77.7	91.9	19.1	52.6	62.0	62.5	63.5	25.4	25.4	60.5	7.9	25.4	17.5
2 1/2	178	90.4	104.6	22.4	62.7	74.7	75.4	69.9	28.4	28.4	73.2	7.9	28.4	19.1
3	191	108.0	127.0	23.9	78.0	90.7	91.4	69.9	30.2	30.2	88.9	9.7	30.2	20.6
3 1/2	216	122.2	139.7	23.9	90.2	103.4	104.1	71.4	31.8	31.8	101.6	9.7	31.8	22.4
4	229	134.9	157.2	23.9	102.4	116.1	116.8	76.2	33.3	33.3	114.3	11.2	33.3	23.9
5	254	163.6	185.7	23.9	128.3	143.8	144.5	88.9	36.6	36.6	141.2	11.2	36.6	23.9
6	279	192.0	215.9	25.4	154.2	170.7	171.5	88.9	39.6	39.6	168.4	12.7	39.6	26.9
8	343	246.1	269.7	28.4	202.7	221.5	222.3	101.6	44.5	44.5	219.2	12.7	44.5	31.8
10	406	304.8	323.9	30.2	254.5	276.4	277.4	101.6	49.3	49.3	273.1	12.7	49.3	33.3
12	483	365.3	381.0	31.8	304.8	327.2	328.2	114.3	55.6	55.6	323.9	12.7	55.6	39.6
14	533	400.1	412.8	35.1	336.6	359.2	360.2	127.0	57.2	79.2	355.6	12.7	57.2	41.4
16	597	457.2	469.9	36.6	387.4	410.5	411.2	127.0	63.5	87.4	406.4	12.7	63.5	44.5
18	635	505.0	533.4	39.6	438.2	461.8	462.3	139.7	68.3	96.8	457.2	12.7	68.3	49.3
20	699	558.8	584.2	42.9	489.0	513.1	514.4	144.5	73.2	103.1	508.0	12.7	73.2	54.1
24	813	663.4	692.2	47.8	590.6	616.0	616.0	152.4	82.6	111.3	609.6	12.7	82.6	63.5

NOTE :

1. For the 'Bore' (B1) other Standard Wall Thickness, refer to page 46,47
2. Class 150 flanges except Lap Joint will be furnished with 0.06" (1.6mm) raised face, which is included in 'Thickness' (t) and 'Length through Hub' (T1), (T2).
3. For Slip-on, Threaded, Socket Welding and Lap Joint Flanges, the hubs can be shaped either vertical from base to top or tapered within the limits of 7 degrees.

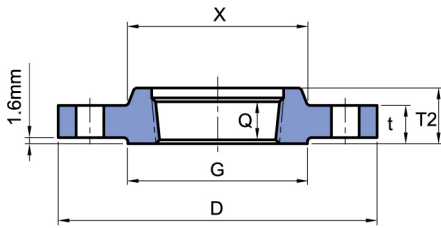

THREADED

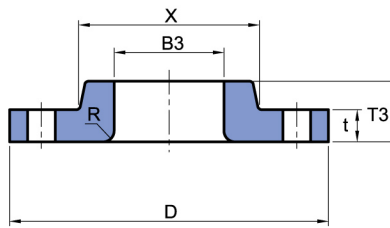

LAP JOINT

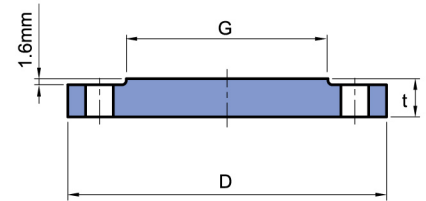

BLIND

Unit : mm

Nominal Pipe Size	DRILLING			BOLTING				APPROXIMATE WEIGHT									
	Bolt Circle Diam.	Number of Holes	Diam. of Holes	Diam. of Bolts (inch)	Machine Bolt Length	Stud Bolt Length		Welding Neck		Slip-on and Threaded		Lap Joint		Blind		Socket Welding	
					Raised Face	Raised Face	Ring Joint	Kg	lb	Kg	lb	Kg	lb	Kg	lb	Kg	lb
1/2	60.5	4	15.7	1/2	50.8	57.2	-	0.51	1.10	0.47	1.00	0.51	1.00	0.47	1.00	0.47	1.00
3/4	69.9	4	15.7	1/2	50.8	63.5	-	0.73	1.60	0.58	1.30	0.64	1.40	0.63	1.40	0.59	1.30
1	79.3	4	15.7	1/2	57.2	63.5	76.2	1.07	2.40	0.86	1.90	0.93	1.80	0.94	2.10	0.87	1.90
1 1/4	88.9	4	15.7	1/2	57.2	69.9	82.6	1.40	3.10	1.08	2.40	1.16	2.00	1.23	2.70	1.11	2.40
1 1/2	98.6	4	15.7	1/2	63.5	69.9	82.6	1.81	4.00	1.41	3.10	1.51	3.30	1.62	3.60	1.45	3.20
2	120.7	4	19.1	5/8	69.9	82.6	95.3	2.59	5.70	2.26	5.00	2.38	5.20	2.64	5.80	2.33	5.00
2 1/2	139.7	4	19.1	5/8	76.2	88.9	101.6	4.28	9.40	3.43	7.60	3.60	7.90	4.06	9.00	3.55	7.80
3	152.4	4	19.1	5/8	76.2	88.9	101.6	5.18	11.40	3.87	8.50	4.04	8.90	4.90	10.80	4.02	8.90
3 1/2	177.8	8	19.1	5/8	76.2	88.9	101.6	5.45	12.00	4.99	11.00	4.99	11.00	5.90	13.00	4.99	11.00
4	190.5	8	19.1	5/8	76.2	88.9	101.6	7.32	16.10	5.75	12.70	5.96	13.00	7.41	16.30	5.99	13.20
5	215.9	8	22.4	3/4	82.6	95.3	108.0	8.91	19.60	6.22	13.70	6.44	14.00	8.76	19.30	6.68	14.70
6	241.3	8	22.4	3/4	82.6	101.6	114.3	11.26	24.80	7.38	16.30	7.59	16.70	11.31	24.90	7.99	17.60
8	298.5	8	22.4	3/4	88.9	108.0	120.7	17.68	39.00	12.36	27.30	12.66	27.90	19.92	43.90	13.29	29.30
10	362.0	12	25.4	7/8	101.6	114.3	127.0	24.79	54.70	17.10	37.70	16.78	37.00	29.39	64.80	19.50	43.00
12	431.8	12	25.4	7/8	101.6	120.7	133.4	38.98	85.90	27.68	61.00	28.30	62.40	43.70	96.30	29.03	64.00
14	476.3	12	28.5	1	114.3	133.4	146.1	51.71	114.00	35.20	77.60	41.50	91.50	59.42	140.00	38.56	85.00
16	539.8	16	28.5	1	114.3	133.4	146.1	64.41	142.00	42.18	93.00	52.98	116.80	77.11	170.00	44.49	98.00
18	577.9	16	31.8	1 1/8	127.0	146.1	158.8	74.84	165.00	49.71	109.60	59.00	130.00	94.80	209.00	54.43	120.00
20	635.0	20	31.8	1 1/8	139.7	158.8	171.5	89.36	197.00	65.50	140.00	72.12	159.00	123.38	272.00	70.31	155.00
24	749.3	20	35.1	1 1/4	152.4	171.5	184.2	119.66	263.80	90.50	199.50	99.02	218.30	188.24	415.00	95.25	210.00

- Blind Flanges may be made with the same hub as that used for Slip-on Flanges or without hub.
- The gasket surface and backside (bearing surface for bolting) are made parallel within 1 degree. To accomplish parallelism, spot facing is carried out according to MSS SP-9, without reducing thickness (t).
- Depth of Socket (Y) is covered by ANSI B 16.5 only in sizes through 3 inch, over 3 inch is at the manufacturer's option.

### CLASS 300 FLANGES

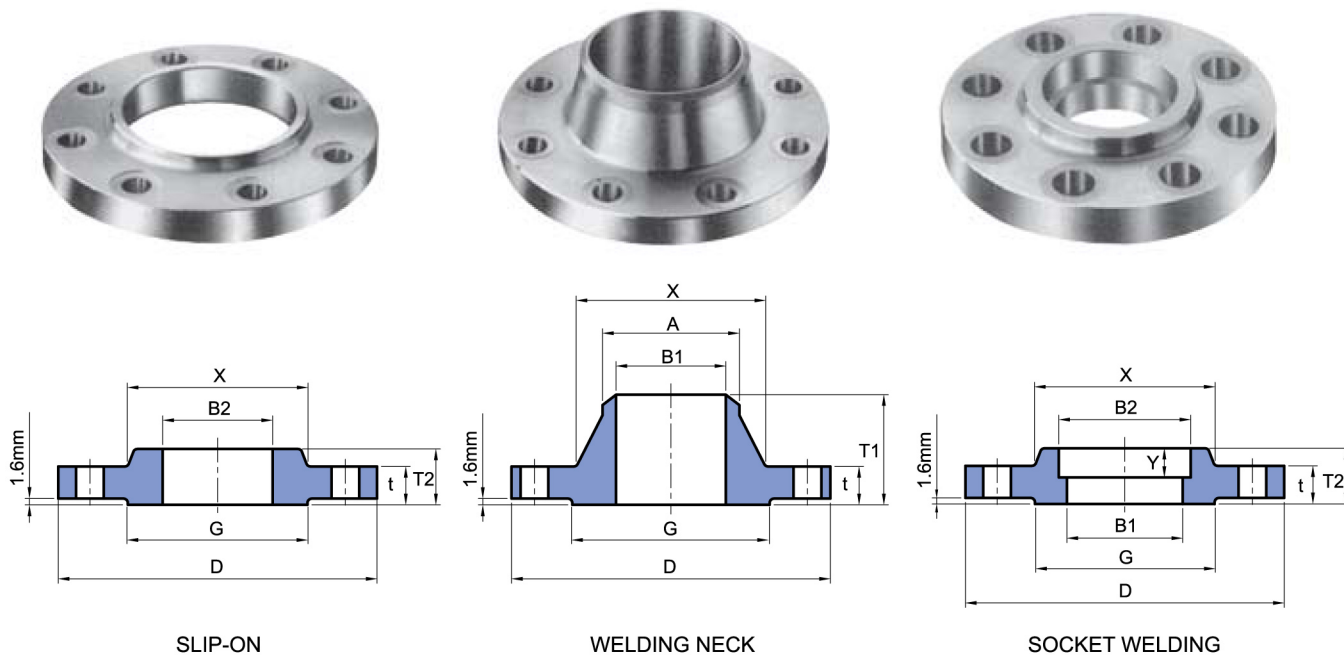

### ANSI B 16.5 Forged Flanges

Unit : mm

Nominal Pipe Size	Outside Diam.	Diam. at Base of Hub	O.D of Raised Face	Thickness	BORE				LENGTH THRU HUB			Diam. of Hub at Bevel	Radius of Fillet	Thread Length	Depth of Socket
					Welding Neck Socket Welding	Slip-on Socket Welding	Lap Joint	Counter Bore Min.	Welding Neck	Slip-on Threaded Socket Welding	Lap Joint				
					B1	B2	B3	B	T1	T2	T3				
1/2	95	38.1	35.1	14.2	15.7	22.4	22.9	23.6	52.3	22.4	22.4	21.3	3.0	15.7	9.7
3/4	117	47.8	42.9	15.7	20.8	27.7	28.2	29.0	57.2	25.4	25.4	26.7	3.0	15.7	11.2
1	124	53.8	50.8	17.5	26.7	34.5	35.1	35.8	62.0	26.9	26.9	33.5	3.0	17.5	12.7
1 1/4	133	63.5	63.5	19.1	35.1	43.2	43.7	44.5	65.0	26.9	26.9	42.2	4.8	20.6	14.2
1 1/2	155	69.9	73.2	20.6	40.9	49.5	50.0	50.5	68.3	30.2	30.2	48.3	6.4	22.4	15.7
2	165	84.1	91.9	22.4	52.6	62.0	62.5	63.5	69.9	33.3	33.3	60.5	7.9	28.4	17.5
2 1/2	191	100.1	104.6	25.4	62.7	74.7	75.4	76.2	76.2	38.1	38.1	73.2	7.9	31.8	19.1
3	210	117.3	127.0	28.4	78.0	90.7	91.4	92.2	79.2	42.9	42.9	88.9	9.7	31.8	20.6
3 1/2	229	133.4	139.7	30.2	90.2	103.4	104.1	104.9	81.0	44.5	44.5	101.6	9.7	36.6	22.4
4	254	146.1	157.2	31.8	102.4	116.1	116.8	117.6	85.9	47.8	47.8	114.3	11.2	36.6	23.9
5	279	177.8	185.7	35.1	128.3	143.8	144.5	144.5	98.6	50.8	50.8	141.2	11.2	42.9	23.9
6	318	206.2	215.9	36.6	154.2	170.7	171.5	171.5	98.6	52.3	52.3	168.4	12.7	46.0	26.9
8	381	260.4	269.7	41.1	202.7	221.5	222.3	222.3	111.3	62.0	62.0	219.2	12.7	50.8	31.8
10	445	320.5	323.9	47.8	254.5	276.4	277.4	276.4	117.3	66.5	95.3	273.1	12.7	55.6	33.3
12	521	374.7	381.0	50.8	304.8	327.2	328.2	328.7	130.0	73.2	101.6	323.9	12.7	60.5	39.6
14	584	425.5	412.8	53.8	336.6	359.2	360.2	360.4	142.7	76.2	111.3	355.6	12.7	63.5	41.4
16	648	482.6	469.9	57.2	387.4	410.5	411.2	411.2	146.1	82.6	120.7	406.4	12.7	68.3	44.5
18	711	533.4	533.4	60.5	438.2	461.8	462.3	462.0	158.8	88.9	130.0	457.2	12.7	69.9	49.3
20	775	587.2	584.2	63.5	489.0	513.1	514.4	512.8	162.1	95.3	139.7	508.0	12.7	73.2	54.1
24	914	701.5	692.2	69.9	590.6	616.0	616.0	614.4	168.1	106.4	152.4	609.6	12.7	82.6	63.5

NOTE :

1. For the 'Bore' (B1) other Standard Wall Thickness, refer to page 46,47
2. Class 300 flanges except Lap Joint will be furnished with 0.06" (1.6mm) raised face, which is included in 'Thickness' (t) and 'Length through Hub' (T1), (T2).
3. For Slip-on, Threaded, Socket Welding and Lap Joint Flanges, the hubs can be shaped either vertical from base to top or tapered within the limits of 7 degrees.



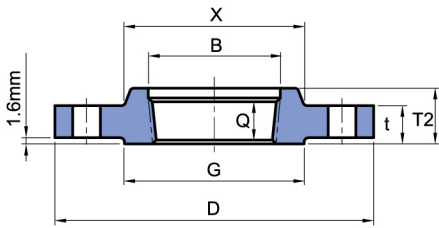

THREADED

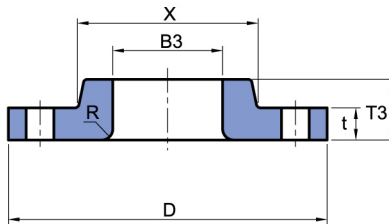

LAP JOINT

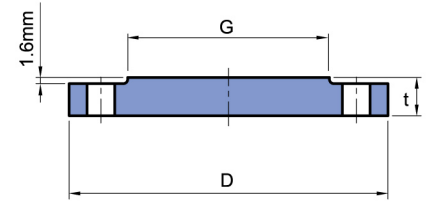

BLIND

Unit : mm

Nominal Pipe Size	DRILLING			BOLTING			APPROXIMATE WEIGHT										
	Bolt Circle Diam.	Number of Holes	Diam. of Holes	Diam. of Bolts (inch)	Machine Bolt Length	Stud Bolt Length		Welding Neck		Slip-on and Threaded		Lap Joint		Blind		Socket Welding	
						Raised Face	Ring Joint	Kg	lb	Kg	lb	Kg	lb	Kg	lb	Kg	lb
1/2	66.5	4	15.7	1/2	57.2	63.5	76.2	0.78	1.70	0.62	1.40	0.61	1.30	0.62	1.40	0.62	1.40
3/4	82.6	4	19.1	5/8	63.5	76.2	88.9	1.34	3.00	1.15	2.50	1.15	2.50	1.16	2.50	1.19	2.60
1	88.9	4	19.1	5/8	63.5	76.2	88.9	1.64	3.60	1.39	3.10	1.38	3.00	1.42	3.00	1.44	3.20
1 1/4	98.6	4	19.1	5/8	69.9	82.6	95.3	2.06	4.50	1.67	3.70	1.66	3.70	1.79	3.90	1.73	3.80
1 1/2	114.3	4	22.4	3/4	76.2	88.9	101.6	3.06	6.70	2.53	5.60	2.52	5.60	2.68	5.90	2.62	5.80
2	127.0	8	19.1	5/8	76.2	88.9	101.6	3.40	7.50	2.80	6.20	2.79	6.20	3.09	6.80	2.94	6.50
2 1/2	149.4	8	22.4	3/4	82.6	101.6	114.3	5.31	11.70	4.25	9.40	4.22	9.30	4.75	10.50	4.49	9.90
3	168.1	8	22.4	3/4	88.9	108.0	120.7	7.32	16.10	5.81	12.80	5.78	12.70	6.79	14.90	6.20	13.70
3 1/2	184.2	8	22.4	3/4	95.3	108.0	127.0	8.17	18.00	7.72	17.00	7.72	17.00	9.53	21.00	-	-
4	200.2	8	22.4	3/4	95.3	114.3	127.0	11.30	24.90	10.13	22.30	10.07	22.20	12.00	26.50	-	-
5	235.0	8	22.4	3/4	108.0	120.7	133.4	15.12	33.30	12.58	27.70	12.52	27.60	15.96	35.20	-	-
6	269.7	12	22.4	3/4	108.0	120.7	139.7	19.68	43.40	16.04	35.40	15.95	35.20	21.20	46.70	-	-
8	330.2	12	25.4	7/8	120.7	139.7	152.4	30.48	67.20	24.50	54.00	24.37	53.70	34.60	76.30	-	-
10	387.4	16	28.4	1	139.7	158.8	171.5	43.74	96.40	34.16	75.30	39.92	88.00	55.34	122.00	-	-
12	450.9	16	31.8	1 1/8	146.1	171.5	184.2	64.41	142.00	51.26	113.00	58.70	129.40	78.90	174.00	-	-
14	514.4	20	31.8	1 1/8	158.8	177.8	190.5	88.30	194.70	72.12	159.00	83.46	184.00	107.05	236.00	-	-
16	571.5	20	35.1	1 1/4	165.1	190.5	203.2	112.94	249.00	90.40	199.30	106.14	234.00	139.25	307.00	-	-
18	628.7	24	35.1	1 1/4	171.5	196.9	209.6	138.34	305.00	109.00	240.30	133.95	295.30	176.90	396.00	-	-
20	685.8	24	35.1	1 1/4	184.2	203.2	222.3	167.37	369.00	136.00	300.00	157.65	347.60	223.17	492.00	-	-
24	812.8	24	41.1	1 1/2	203.2	228.6	254.0	235.41	519.00	204.00	449.70	240.40	530.00	342.00	754.00	-	-

- Blind Flanges may be made with the same hub as that used for Slip-on Flanges or without hub.
- The gasket surface and backside (bearing surface for bolting) are made parallel within 1 degree. To accomplish parallelism, spot facing is carried out according to MSS SP-9, without reducing thickness (t).
- Depth of Socket (Y) is covered by ANSI B 16.5 only in sizes through 3 inch, over 3 inch is at the manufacturer's option.



# CLASS 400 FLANGES

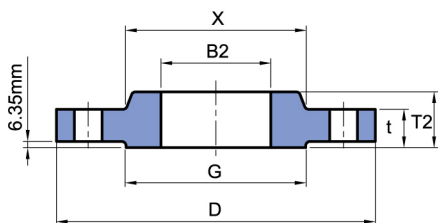

SLIP-ON

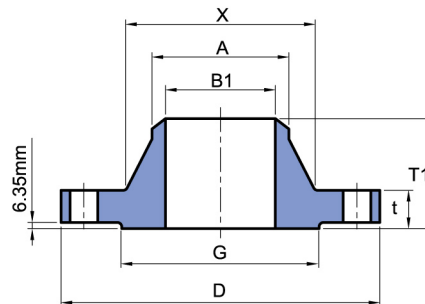

WELDING NECK

## ANSI B 16.5 Forged Flanges

Unit : mm

Nominal Pipe Size	Outside Diam.	Diam. at Base of Hub	O.D. of Raised Face	Thickness	BORE				LENGTH THRU HUB			Diam. of Hub at Bevel	Radius of Fillet	Thread Length
					Welding Neck	Slip-on	Lap Joint	Counter Bore Min.	Welding Neck	Slip-on Threaded	Lap Joint			
					B1	B2	B3	B	T1	T2	T3			
1/2	95	38.1	35.1	14.2	See Note (1) To be specified by purchaser.	22.4	22.9	23.6	52.3	22.4	22.4	21.3	3.0	15.7
3/4	117	47.8	42.9	15.7		27.7	28.2	29.0	57.2	25.4	25.4	26.7	3.0	15.7
1	124	53.8	50.8	17.5		34.5	35.1	35.8	62.0	26.9	26.9	33.5	3.0	17.5
1 1/4	133	63.5	63.5	20.6		43.2	43.7	44.5	66.5	28.4	28.4	42.2	4.8	20.6
1 1/2	155	69.9	73.2	22.4		49.5	50.0	50.5	69.9	31.8	31.8	48.3	6.4	22.4
2	165	84.1	91.9	25.4		62.0	62.5	63.5	73.2	36.6	36.6	60.5	7.9	28.4
2 1/2	191	100.1	104.6	28.4		74.7	75.4	76.2	79.2	41.1	41.1	73.2	7.9	31.8
3	210	117.3	127.0	31.8		90.7	91.4	92.2	82.6	46.0	46.0	88.9	9.7	35.1
3 1/2	229	133.4	139.7	35.1		103.4	104.1	104.9	85.9	49.3	49.3	101.6	9.7	39.6
4	254	146.1	157.2	35.1		116.1	116.8	117.6	88.9	50.8	50.8	114.3	11.2	36.6
5	279	177.8	185.7	38.1		143.8	144.5	144.5	101.6	53.8	53.8	141.2	11.2	42.9
6	318	206.2	215.9	41.1		170.7	171.5	171.5	103.1	57.2	57.2	168.4	12.7	46.0
8	381	260.4	269.7	47.8		221.5	222.3	222.3	117.3	68.3	68.3	219.2	12.7	50.8
10	445	320.5	323.9	53.8		276.4	277.4	276.4	124.0	73.2	101.6	273.1	12.7	55.6
12	521	374.7	381.0	57.2		327.2	328.2	328.7	136.7	79.2	108.0	323.9	12.7	60.5
14	584	425.5	412.8	60.5		359.2	360.2	360.4	149.4	84.1	117.3	355.6	12.7	63.5
16	648	482.6	469.9	63.5		410.5	411.2	411.2	152.4	93.7	127.0	406.4	12.7	68.3
18	711	533.4	533.4	66.5		461.8	462.3	462.0	165.1	98.6	136.7	457.2	12.7	69.9
20	775	587.2	584.2	69.9		513.1	514.4	512.8	168.1	101.6	146.1	508.0	12.7	73.2
24	914	701.5	692.2	76.2		616.0	616.0	614.4	174.8	114.3	158.8	609.6	12.7	82.6

NOTE :

1. For the 'Bore' (B1) other Standard Wall Thickness, refer to page 46,47
2. Class 400 flanges except Lap Joint will be furnished with 0.25" (6.35mm) raised face, which is included in 'Thickness' (t) and 'Length through Hub' (T1), (T2).
3. For Slip-on, Threaded, Socket Welding and Lap Joint Flanges, the hubs can be shaped either vertical from base to top or tapered within the limits of 7 degrees.

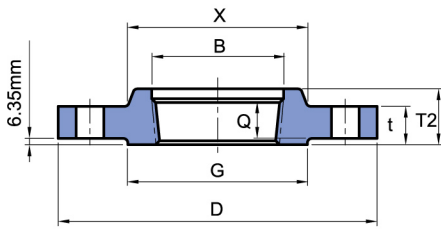

THREADED

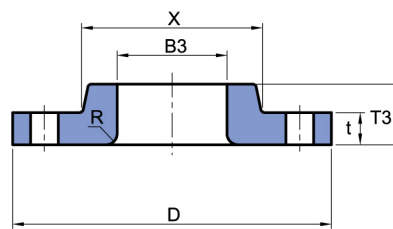

LAP JOINT

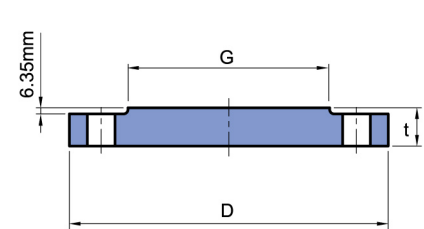

BLIND

Unit : mm

Nominal Pipe Size	DRILLING			BOLTING				APPROXIMATE WEIGHT							
	Bolt Circle Diam.	Number of Holes	Diam. of Holes	Diam. of Bolts (inch)	Stud Bolt Length			Welding Neck		Slip-on and Threaded		Lap Joint		Blind	
					0.25" Raised Face	Male-Female Tongue-Groove	Ring Joint								
Kg	lb	Kg	lb	Kg	lb	Kg	lb	Kg	lb						
1/2	66.5	4	15.7	1/2	76.2	69.9	76.2	1.36	3.00	0.91	2.00	0.80	1.80	0.91	2.00
3/4	82.6	4	19.1	5/8	88.9	82.6	88.9	1.59	3.50	1.36	3.00	1.36	3.00	1.40	3.00
1	88.9	4	19.1	5/8	88.9	82.6	88.9	1.81	4.00	1.59	3.50	1.59	3.50	1.70	3.80
1 1/4	98.6	4	19.1	5/8	95.3	88.9	95.3	2.50	5.50	2.10	4.60	2.04	4.50	2.27	5.00
1 1/2	114.3	4	22.4	3/4	108.0	101.6	108.0	3.63	8.00	3.10	6.80	2.95	6.50	3.40	7.50
2	127.0	8	19.1	5/8	108.0	101.6	108.0	4.54	10.00	3.63	8.00	3.63	8.00	4.40	9.70
2 1/2	149.4	8	22.4	3/4	120.7	114.3	120.7	6.35	14.00	5.44	12.00	4.99	11.00	6.80	15.00
3	168.1	8	22.4	3/4	127.0	120.7	127.0	8.17	18.00	7.26	16.00	6.35	14.00	8.90	19.60
3 1/2	184.2	8	25.4	7/8	139.7	133.4	139.7	11.80	26.00	9.53	21.00	9.08	20.00	13.17	29.00
4	200.2	8	25.4	7/8	139.7	133.4	139.7	13.61	30.00	10.89	24.00	9.98	22.00	14.40	31.70
5	235.0	8	25.4	7/8	146.1	139.7	146.1	17.69	39.00	14.07	31.00	13.15	29.00	19.50	43.00
6	269.7	12	25.4	7/8	152.4	146.1	152.4	22.23	49.00	19.98	44.00	16.78	37.00	27.67	61.00
8	330.2	12	28.4	1	171.5	165.1	171.5	35.38	78.00	30.40	67.00	26.16	59.00	45.36	100.00
10	387.4	16	31.8	1 1/8	190.5	184.2	190.5	49.89	110.00	41.28	91.00	43.09	95.00	68.00	150.00
12	450.9	16	35.1	1 1/4	203.2	196.9	203.2	72.57	160.00	59.02	130.00	68.95	152.00	98.00	216.00
14	514.4	20	35.1	1 1/4	209.6	203.2	209.6	105.69	233.00	81.72	180.00	95.25	210.00	131.66	290.00
16	571.5	20	38.1	1 3/8	222.3	215.9	222.3	133.30	294.00	106.69	235.00	127.00	280.00	167.00	368.00
18	628.7	24	38.1	1 3/8	228.6	222.3	228.6	158.90	350.30	129.39	285.30	156.49	345.00	206.57	455.40
20	685.8	24	41.1	1 1/2	241.3	235.0	247.7	193.00	425.50	152.00	335.00	190.51	420.00	261.00	575.40
24	812.8	24	47.8	1 3/4	266.7	260.4	279.4	281.48	620.50	231.54	510.50	278.96	615.00	395.00	870.80

4. Blind Flanges may be made with the same hub as that used for Slip-on Flanges or without hub.
5. The gasket surface and backside (bearing surface for bolting) are made parallel within 1 degree. To accomplish parallelism, spot facing is carried out according to MSS SP-9, without reducing thickness (t).
6. Dimensions of size 1/2" through 3 1/2" are the same as for Class 600 Flanges.

CLASS 600 FLANGES

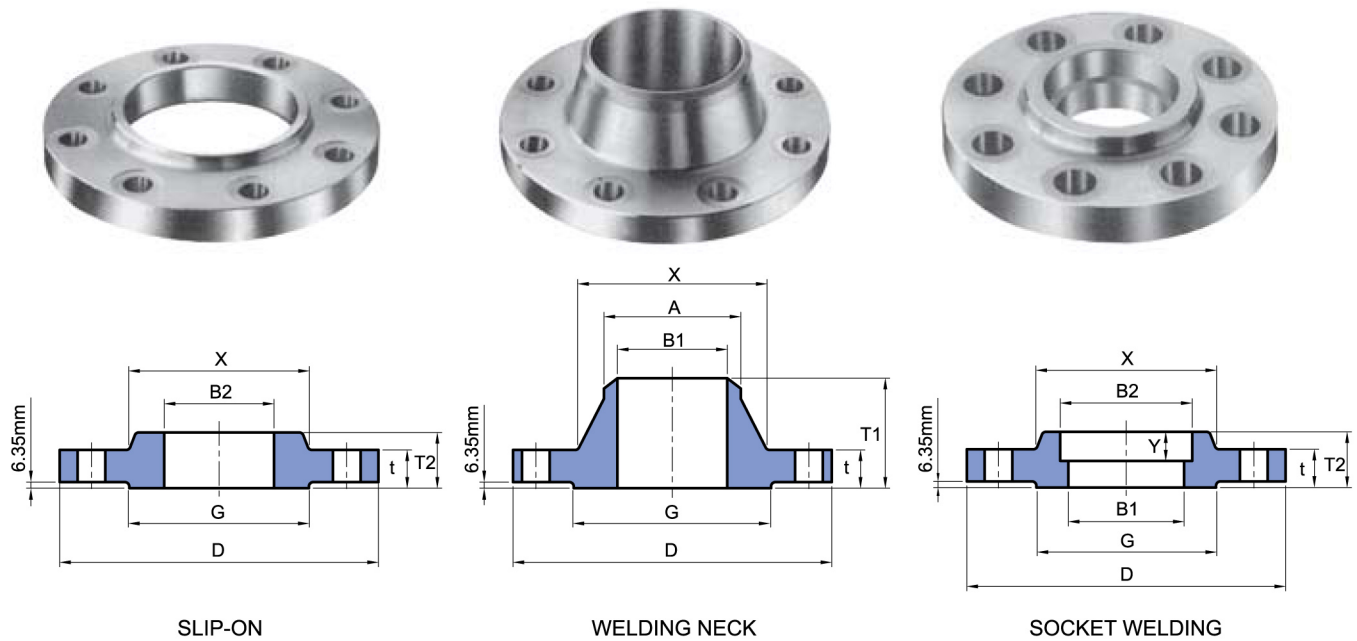

ANSI B 16.5 Forged Flanges

Unit : mm

Nominal Pipe Size	Outside Diam.	Diam. at Base of Hub	O.D of Raised Face	Thickness	BORE				LENGTH THRU HUB			Diam. of Hub at Bevel	Radius of Fillet	Thread Length	Depth of Socket
					Welding Neck Socket Welding	Slip-on Socket Welding	Lap Joint	Counter Bore Min.	Welding Neck	Slip-on Threaded Socket Welding	Lap Joint				
					B1	B2	B3	B	T1	T2	T3				
1/2	95	38.1	35.1	14.2	See Note (1) To be specified by purchaser.	22.4	22.9	23.6	52.3	22.4	22.4	21.3	3.0	15.7	9.7
3/4	117	47.8	42.9	15.7		27.7	28.2	29.0	57.2	25.4	25.4	26.7	3.0	15.7	11.2
1	124	53.8	50.8	17.5		34.5	35.1	35.8	62.0	26.9	26.9	33.5	3.0	17.5	12.7
1 1/4	133	63.5	63.5	20.6		43.2	43.7	44.5	66.5	28.4	28.4	42.2	4.8	20.6	14.2
1 1/2	155	69.9	73.2	22.4		49.5	50.0	50.5	69.9	31.8	31.8	48.3	6.4	22.4	15.7
2	165	84.1	91.9	25.4		62.0	62.5	63.5	73.2	36.6	36.6	60.5	7.9	28.4	17.5
2 1/2	191	100.1	104.6	28.4		74.7	75.4	76.2	79.2	41.1	41.1	73.2	7.9	31.8	19.1
3	210	117.3	127.0	31.8		90.7	91.4	92.2	82.6	46.0	46.0	88.9	9.7	35.1	20.6
3 1/2	229	133.4	139.7	35.1		103.4	104.1	104.9	85.9	49.3	49.3	101.6	9.7	39.6	22.4
4	273	152.4	157.2	38.1		116.1	116.8	117.6	101.6	53.8	53.8	114.3	11.2	41.1	23.9
5	330	189.0	185.7	44.5		143.8	144.5	144.5	114.3	60.5	60.5	141.2	11.2	47.8	23.9
6	356	222.3	215.9	47.8		170.7	171.5	171.5	117.3	66.5	66.5	168.4	12.7	50.8	26.9
8	419	273.1	269.7	55.6		221.5	222.3	222.3	133.4	76.2	76.2	219.2	12.7	57.2	31.8
10	508	342.9	323.9	63.5		276.4	277.4	276.4	152.4	85.9	111.3	273.1	12.7	65.0	33.3
12	559	400.1	381.0	66.5		327.2	328.2	328.7	155.4	91.9	117.3	323.9	12.7	69.9	39.6
14	603	431.8	412.8	69.9		359.2	360.2	360.4	165.1	93.7	127.0	355.6	12.7	73.2	41.4
16	686	495.3	469.9	76.2		410.5	411.2	411.2	177.8	106.4	139.7	406.4	12.7	77.7	44.5
18	743	546.1	533.4	82.6		461.8	462.3	462.0	184.2	117.3	152.4	457.2	12.7	79.2	49.3
20	813	609.6	584.2	88.9		513.1	514.4	512.8	190.5	127.0	165.1	508.0	12.7	82.6	54.1
24	940	717.6	692.2	101.6		616.0	616.0	614.4	203.2	139.7	184.2	609.6	12.7	91.9	63.5

NOTE :

1. For the 'Bore' (B1) other Standard Wall Thickness, refer to page 46,47
2. Class 600 flanges except Lap Joint will be furnished with 0.25" (6.35mm) raised face, which is included in 'Thickness' (t) and 'Length through Hub' (T1), (T2).
3. For Slip-on, Threaded, Socket Welding and Lap Joint Flanges, the hubs can be shaped either vertical from base to top or tapered within the limits of 7 degrees.

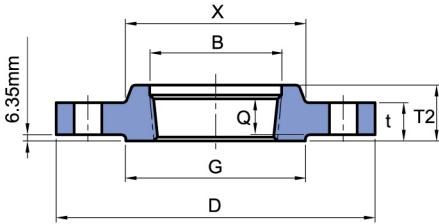

THREADED

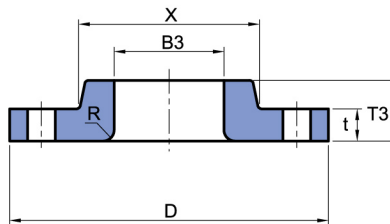

LAP JOINT

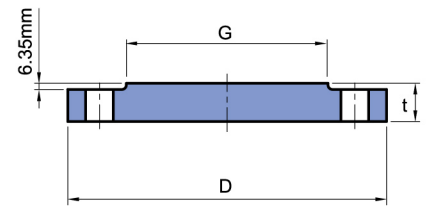

BLIND

Unit : mm

Nominal Pipe Size	DRILLING			BOLTING			APPROXIMATE WEIGHT										
	Bolt Circle Diam.	Number of Holes	Diam. of Holes	Diam. of Bolts (inch)	STUD BOLT LENGTH			Welding Neck		Slip-on and Threaded		Lap Joint		Blind		Socket Welding	
					0.25" Raised Face	Male - Female Tongue - Groove	Ring Joint	Kg	lb	Kg	lb	Kg	lb	Kg	lb	Kg	lb
1/2	66.5	4	15.7	1/2	76.2	69.9	76.2	0.90	2.00	0.91	2.00	0.80	1.80	0.91	2.00	0.91	2.00
3/4	82.6	4	19.1	5/8	88.9	82.6	88.9	1.59	3.50	1.40	3.00	1.36	3.00	1.40	3.00	1.36	3.00
1	88.9	4	19.1	5/8	88.9	82.6	88.9	1.90	4.00	1.70	3.70	1.59	3.50	1.81	4.00	1.81	4.00
1 1/4	98.6	4	19.1	5/8	95.3	88.9	95.3	2.49	5.50	2.27	5.00	2.04	4.50	2.40	5.30	2.60	5.70
1 1/2	114.3	4	22.4	3/4	108.0	101.6	108.0	3.63	8.00	3.10	6.80	2.95	6.50	3.40	7.50	3.18	7.00
2	127.0	8	19.1	5/8	108.0	101.6	108.0	4.54	10.00	3.63	8.00	3.63	8.00	4.40	9.70	3.90	8.60
2 1/2	149.4	8	22.4	3/4	120.7	114.3	120.7	6.35	14.00	5.44	12.00	4.99	11.00	6.80	15.00	5.90	13.00
3	168.1	8	22.4	3/4	127.0	120.7	127.0	8.16	18.00	7.26	16.00	6.35	14.00	8.90	19.60	7.40	16.30
3 1/2	184.2	8	25.4	7/8	139.7	133.4	139.7	11.80	26.00	9.53	21.00	9.08	20.00	13.17	29.00	-	-
4	215.9	8	25.4	7/8	146.1	139.7	146.1	16.78	37.00	14.97	33.00	14.06	31.00	18.60	41.00	-	-
5	266.7	8	28.4	1	165.1	158.8	165.1	30.87	68.00	28.50	62.80	27.50	60.60	30.84	68.00	-	-
6	292.1	12	28.4	1	171.5	165.1	171.5	36.77	80.00	36.32	80.00	35.38	78.00	38.00	83.80	-	-
8	349.3	12	31.8	1 1/8	190.5	184.2	196.9	50.80	112.00	44.00	97.00	50.80	112.00	62.20	137.00	-	-
10	431.8	16	35.1	1 1/4	215.9	209.6	215.9	86.26	190.00	76.20	168.00	74.00	163.00	102.00	224.90	-	-
12	489.0	20	35.1	1 1/4	222.3	215.9	222.3	102.51	226.00	97.52	215.00	108.86	240.00	132.00	291.00	-	-
14	527.1	20	38.1	1 3/8	235.0	228.6	235.0	121.56	268.00	102.00	224.80	111.00	244.70	158.00	348.30	-	-
16	603.3	20	41.1	1 1/2	254.0	247.7	254.0	177.06	290.00	149.82	330.20	165.71	365.30	224.73	495.40	-	-
18	654.1	20	44.5	1 5/8	273.1	266.7	273.1	215.65	475.40	180.10	412.30	194.00	427.70	285.00	628.30	-	-
20	723.9	24	44.5	1 5/8	285.8	279.4	292.1	267.86	590.50	231.54	510.50	258.78	570.50	365.00	804.70	-	-
24	838.2	24	50.8	1 7/8	330.2	323.9	336.6	372.00	820.00	330.00	725.50	362.00	798.00	533.45	1176.00	-	-

- Blind Flanges may be made with the same hub as that used for Slip-on Flanges or without hub.
- The gasket surface and backside (bearing surface for bolting) are made parallel within 1 degree. To accomplish parallelism, spot facing is carried out according to MSS SP-9, without reducing thickness (t).
- Dimensions of sizes 1/2" through 3 1/2" are the same as for Class 400 Flanges.
- Depth of Socket (Y) is covered by ANSI B 16.5 only in sizes through 3 inch, over 3 inch is at the manufacturer's option.



# CLASS 900 FLANGES

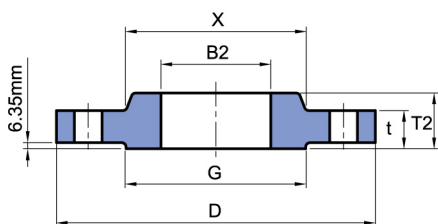

SLIP-ON

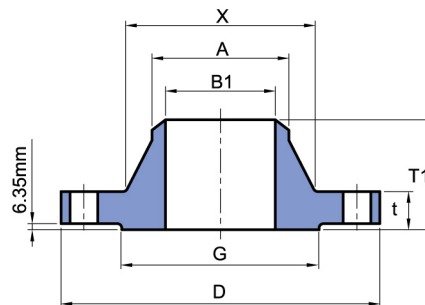

WELDING NECK

## ANSI B 16.5 Forged Flanges

Unit : mm

Nominal Pipe Size	Outside Diam.	Diam. at Base of Hub	O.D of Raised Face	Thickness	BORE				LENGTH THRU HUB			Diam. of Hub at Bevel	Radius of Fillet	Thread Length
					Welding Neck	Slip-on	Lap Joint	Counter Bore Min.	Welding Neck	Slip-on Threaded	Lap Joint			
					B1	B2	B3	B	T1	T2	T3			
1/2	121	38.1	35.1	22.4	See Note (1) To be specified by purchaser.	22.4	22.9	23.6	60.5	31.8	31.8	21.3	3.0	22.4
3/4	130	44.5	42.9	25.4		27.7	28.2	29.0	69.9	35.1	35.1	26.7	3.0	25.4
1	149	52.3	50.8	28.4		34.5	35.1	35.8	73.2	41.1	41.1	33.5	3.0	28.4
1 1/4	159	63.5	63.5	28.4		43.2	43.7	44.5	73.2	41.1	41.1	42.2	4.8	30.2
1 1/2	178	69.9	73.2	31.8		49.5	50.0	50.5	82.6	44.5	44.5	48.3	6.4	31.8
2	216	104.6	91.9	38.1		62.0	62.5	63.5	101.6	57.2	57.2	60.5	7.9	38.1
2 1/2	244	124.0	104.6	41.1		74.7	75.4	76.2	104.6	63.5	63.5	73.2	7.9	47.8
3	241	127.0	127.0	38.1		90.7	91.4	92.2	101.6	53.8	53.8	88.9	9.7	41.1
4	292	158.8	157.2	44.5		116.1	116.8	117.6	114.3	69.9	69.9	114.3	11.2	47.8
5	349	190.5	185.7	50.8		143.8	144.5	144.5	127.0	79.2	79.2	141.2	11.2	53.8
6	381	235.0	215.9	55.6		170.7	171.5	171.5	139.7	85.9	85.9	168.4	12.7	57.2
8	470	298.5	269.7	63.5		221.5	222.3	222.3	162.1	101.6	114.3	219.2	12.7	63.5
10	546	368.3	323.9	69.9		276.4	277.4	276.4	184.2	108.0	127.0	273.1	12.7	71.4
12	610	419.1	381.0	79.2		327.2	328.2	328.7	200.2	117.3	142.7	323.9	12.7	76.2
14	641	450.9	412.8	85.9		359.2	360.2	360.4	212.9	130.0	155.4	355.6	12.7	82.6
16	705	508.0	469.9	88.9		410.5	411.2	411.2	215.9	133.4	165.1	406.4	12.7	85.9
18	787	565.2	533.4	101.6	461.8	462.3	462.0	228.6	152.4	190.5	457.2	12.7	88.9	
20	857	622.3	584.2	108.0	513.1	514.4	512.8	247.7	158.8	209.6	508.0	12.7	91.9	
24	1041	749.3	692.2	139.7	616.0	616.0	614.4	292.1	203.2	266.7	609.6	12.7	101.6	

NOTE :

1. For the 'Bore' (B1) other Standard Wall Thickness, refer to page 46,47
2. Class 900 flanges except Lap Joint will be furnished with 0.25" (6.35mm) raised face, which is included in 'Thickness' (t) and 'Length through Hub' (T1), (T2).
3. For Slip-on, Threaded, Socket Welding and Lap Joint Flanges, the hubs can be shaped either vertical from base to top or tapered within the limits of 7 degrees.



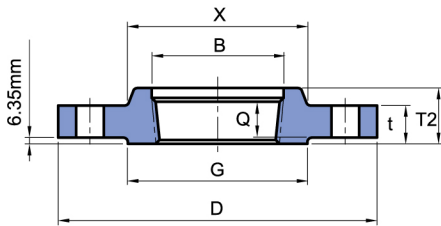

THREADED

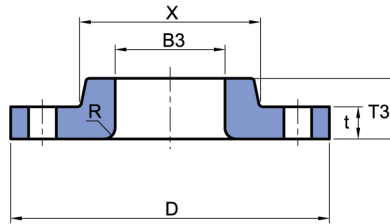

LAP JOINT

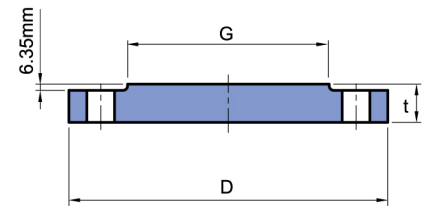

BLIND

Unit : mm

Nominal Pipe Size	DRILLING			BOLTING				APPROXIMATE WEIGHT							
				Diam. of Bolts (inch)	STUD BOLT LENGTH			Welding Neck		Slip-on and Threaded		Lap Joint		Blind	
	Bolt Circle Diam.	Number of Holes	Diam. of Holes		0.25" Raised Face	Male - Female Tongue - Groove	Ring Joint	Kg	lb	Kg	lb	Kg	lb	Kg	lb
1/2	82.6	4	22.4	3/4	108.0	101.6	108.0	2.10	4.60	1.81	4.00	1.81	4.00	1.90	4.20
3/4	88.9	4	22.4	3/4	114.3	108.0	114.3	2.72	6.00	2.40	5.30	2.30	5.00	2.70	6.00
1	101.6	4	25.4	7/8	127.0	120.7	127.0	3.86	8.50	3.41	7.50	3.40	7.50	4.09	9.00
1 1/4	111.3	4	25.4	7/8	127.0	120.7	127.0	4.54	10.00	4.10	9.00	4.09	9.00	4.54	10.00
1 1/2	124.0	4	28.4	1	139.7	133.4	139.7	5.90	13.00	5.45	12.00	5.40	11.90	5.90	13.00
2	165.1	8	25.4	7/8	146.1	139.7	146.1	10.89	24.00	9.98	22.00	9.53	21.00	11.34	25.00
2 1/2	190.5	8	28.4	1	158.8	152.4	158.8	16.33	36.00	15.80	34.80	13.15	29.00	16.00	35.30
3	190.5	8	25.4	7/8	146.1	139.7	146.1	15.00	33.00	11.80	26.00	11.34	25.00	13.17	29.00
4	235.0	8	31.8	1 1/8	171.5	165.1	171.5	23.13	51.00	23.20	51.00	22.60	48.50	24.50	54.00
5	279.4	8	35.1	1 1/4	190.5	184.2	190.5	38.50	84.90	37.65	83.00	36.74	81.00	39.46	87.00
6	317.5	12	31.8	1 1/8	190.5	184.2	196.9	49.89	110.00	48.30	106.50	47.50	104.70	51.50	113.50
8	393.7	12	38.1	1 3/8	222.3	215.9	222.3	79.45	175.00	75.00	166.30	86.00	189.60	89.00	106.20
10	469.9	16	38.1	1 3/8	235.0	228.6	235.0	118.04	260.00	111.13	245.00	125.64	277.00	131.54	290.00
12	533.4	20	38.1	1 3/8	254.0	247.7	254.0	157.00	346.00	146.00	321.80	167.00	368.00	187.00	412.30
14	558.8	20	41.1	1 1/2	273.1	266.7	279.4	181.60	400.40	172.36	380.00	180.07	397.00	224.07	494.00
16	616.0	20	44.5	1 5/8	285.8	279.4	292.1	224.73	495.50	192.95	425.40	211.11	465.40	272.40	600.50
18	685.8	20	50.8	1 7/8	323.9	317.5	336.6	308.72	680.60	272.40	600.50	295.10	650.60	385.90	850.80
20	749.3	20	53.8	2	349.3	342.9	362.0	376.82	830.70	331.42	730.60	367.74	810.70	488.00	1076.00
24	901.7	20	66.5	2 1/2	438.2	431.8	457.2	685.00	1510.00	632.00	1393.30	700.00	1543.00	905.00	1995.00

- Blind Flanges may be made with the same hub as that used for Slip-on Flanges or without hub.
- The gasket surface and backside (bearing surface for bolting) are made parallel within 1 degree. To accomplish parallelism, spot facing is carried out according to MSS SP-9, without reducing thickness (t).
- Dimensions of size 1/2" through 2 1/2" are the same as for Class 1500 Flanges.

# CLASS 1500 FLANGES

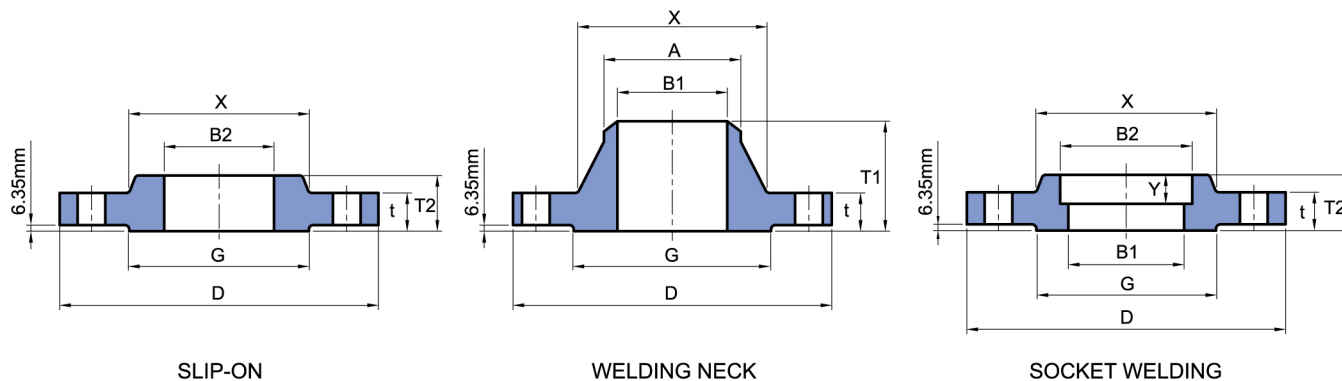

SLIP-ON

WELDING NECK

SOCKET WELDING

## ANSI B 16.5 Forged Flanges

Unit : mm

Nominal Pipe Size	Outside Diam.	Diam. at Base of Hub	O.D of Raised Face	Thickness	BORE				LENGTH THRU HUB			Diam. of Hub at Bevel	Radius of Fillet	Thread Length	Depth of Socket
					Welding Neck Socket Welding	Slip-on Socket Welding	Lap Joint	Counter Bore Min.	Welding Neck	Slip-on Threaded Socket Welding	Lap Joint				
					B1	B2	B3	B	T1	T2	T3				
1/2	121	38.1	35.1	22.4	See Note (1) To be specified by purchaser.	22.4	22.9	23.6	60.5	31.8	31.8	21.3	3.0	22.4	9.7
3/4	130	44.5	42.9	25.4		27.7	28.2	29.0	69.9	35.1	35.1	26.7	3.0	25.4	11.2
1	149	52.3	50.8	28.4		34.5	35.1	35.8	73.2	41.1	41.1	33.5	3.0	28.4	12.7
1 1/4	159	63.5	63.5	28.4		43.2	43.7	44.5	73.2	41.1	41.1	42.2	4.8	30.2	14.2
1 1/2	178	69.9	73.2	31.8		49.5	50.0	50.5	82.6	44.5	44.5	48.3	6.4	31.8	15.7
2	216	104.6	91.9	38.1		62.0	62.5	63.5	101.6	57.2	57.2	60.5	7.9	38.1	17.5
2 1/2	244	124.0	104.6	41.1		74.7	75.4	76.2	104.6	63.5	63.5	73.2	7.9	47.8	19.1
3	267	133.4	127.0	47.8		90.7	91.4	92.2	117.3	73.2	73.2	88.9	9.7	50.8	20.6
4	311	162.1	157.2	53.8		116.1	116.8	117.6	124.0	90.4	90.4	114.3	11.2	57.2	23.9
5	375	196.9	185.7	73.2		143.8	144.5	144.5	155.4	104.6	104.6	141.2	11.2	63.5	23.9
6	394	228.6	215.9	82.6		170.7	171.5	171.5	171.5	119.1	119.1	168.4	12.7	69.9	26.9
8	483	292.1	269.7	91.9		221.5	222.3	222.3	212.9	142.7	142.7	219.2	12.7	76.2	31.8
10	584	368.3	323.9	108.0		276.4	277.4	276.4	254.0	158.8	177.8	273.1	12.7	84.1	33.3
12	673	450.9	381.0	124.0		327.1	328.2	328.7	282.4	180.8	218.9	323.9	12.7	91.9	39.6
14	749	495.3	412.8	133.4		359.2	360.2	360.4	298.5	-	241.3	355.6	12.7	-	41.4
16	826	552.5	469.9	146.1		410.5	411.2	411.2	311.2	-	260.4	406.4	12.7	-	44.5
18	914	596.9	533.4	162.1	461.8	462.3	462.0	327.2	-	276.4	457.2	12.7	-	49.3	
20	984	641.4	584.2	177.8	513.1	514.4	512.8	355.6	-	292.1	508.0	12.7	-	54.1	
24	1168	762.0	692.2	203.2	616.0	616.0	614.4	406.4	-	330.2	609.6	12.7	-	63.5	

NOTE :

1. For the 'Bore' (B1) other Standard Wall Thickness, refer to page 46,47
2. Class 1500 flanges except Lap Joint will be furnished with 0.25" (6.35mm) raised face, which is included in 'Thickness' (t) and 'Length through Hub' (T1), (T2).
3. For Slip-on, Threaded, Socket Welding and Lap Joint Flanges, the hubs can be shaped either vertical from base to top or tapered within the limits of 7 degrees.

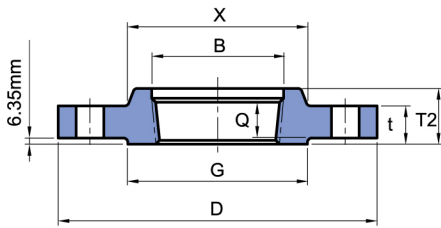

THREADED

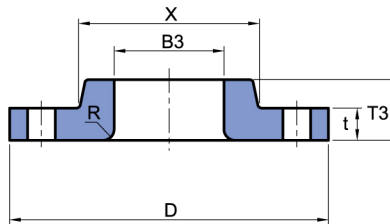

LAP JOINT

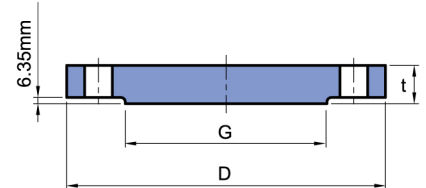

BLIND

Unit : mm

Nominal Pipe Size	DRILLING			BOLTING			APPROXIMATE WEIGHT										
	Bolt Circle Diam.	Number of Holes	Diam. of Holes	Diam. of Bolts (inch)	STUD BOLT LENGTH			Welding Neck		Slip-on and Threaded		Lap Joint		Blind		Socket Welding	
					0.25" Raised Face	Male - Female Tongue - Groove	Ring Joint	Kg	lb	Kg	lb	Kg	lb	Kg	lb	Kg	lb
1/2	82.6	4	22.4	3/4	108.0	101.6	108.0	2.10	4.60	1.80	4.00	1.80	4.00	1.90	4.00	1.81	4.00
3/4	88.9	4	22.4	3/4	114.3	108.0	114.3	2.72	6.00	2.27	5.00	2.27	5.00	2.72	6.00	2.81	6.20
1	101.6	4	25.4	7/8	127.0	120.7	127.0	3.86	8.50	3.40	7.50	3.40	7.50	4.08	9.00	3.61	8.00
1 1/4	111.3	4	25.4	7/8	127.0	120.7	127.0	4.54	10.00	4.10	9.00	4.09	10.80	4.30	9.50	4.99	11.00
1 1/2	124.0	4	28.4	1	139.7	133.4	139.7	5.90	13.00	5.45	12.00	5.40	11.90	5.90	13.00	6.76	14.90
2	165.1	8	25.4	7/8	146.1	139.7	146.1	10.89	24.00	10.50	23.00	9.53	21.00	11.30	25.00	10.89	24.00
2 1/2	190.5	8	28.4	1	158.8	152.4	158.8	16.34	36.00	15.80	34.80	13.15	29.00	16.00	35.30	16.34	36.00
3	203.2	8	31.8	1 1/8	177.8	171.5	177.8	21.79	48.00	21.77	48.00	17.24	38.00	21.79	48.00	-	-
4	241.3	8	35.1	1 1/4	196.9	190.5	196.9	31.30	69.00	31.00	68.40	29.00	63.90	33.11	73.00	-	-
5	292.1	8	41.1	1 1/2	247.7	241.3	247.7	59.02	130.00	58.80	129.60	54.00	119.00	60.00	132.30	-	-
6	317.5	12	38.1	1 3/8	260.4	254.0	266.7	74.91	165.00	74.00	163.00	62.00	136.70	75.00	165.30	-	-
8	393.7	12	44.5	1 5/8	292.1	285.8	323.9	123.83	273.00	117.73	258.00	129.73	236.00	136.98	302.00	-	-
10	482.6	12	50.8	1 7/8	336.6	330.2	342.9	205.93	454.00	197.49	435.40	220.19	485.40	229.97	507.00	-	-
12	571.5	16	53.8	2	374.7	368.3	387.4	306.00	674.60	264.00	582.00	286.02	630.60	316.00	696.70	-	-
14	635.0	16	60.5	2 1/4	406.4	400.1	425.5	416.00	917.00	-	-	404.06	890.80	421.00	928.00	-	-
16	704.9	16	66.5	2 1/2	444.5	438.2	469.9	567.50	1250.00	-	-	522.10	1151.00	559.00	1232.70	-	-
18	774.7	16	73.2	2 3/4	495.3	489.0	527.1	736.00	1622.60	-	-	669.65	1476.30	761.00	1677.70	-	-
20	831.9	16	79.2	3	539.8	533.4	565.2	929.00	2048.00	-	-	805.85	1776.60	967.00	2131.80	-	-
24	990.6	16	91.9	3 1/2	616.0	609.6	647.7	1504.00	3315.70	-	-	1285.55	2834.00	1568.00	3456.80	-	-

- 4. Blind Flanges may be made with the same hub as that used for Slip-on Flanges or without hub.
- 5. The gasket surface and backside (bearing surface for bolting) are made parallel within 1 degree. To accomplish parallelism, spot facing is carried out according to MSS SP-9, without reducing thickness (t).
- 6. Dimensions of sizes 1/2" through 2 1/2" are the same as for Class 900 Flanges.
- 7. Depth of Socket (Y) is covered by ANSI B 16.5 only in sizes through 2 1/2 inch, over 2 1/2 inch is at the manufacturer's option.

## CLASS 2500 FLANGES

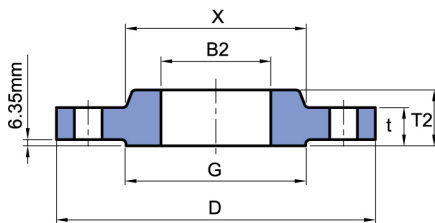

SLIP-ON

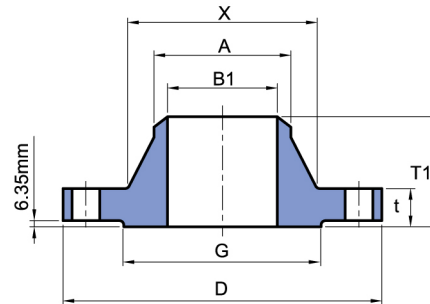

WELDING NECK

## ANSI B 16.5 Forged Flanges

Unit : mm

Nominal Pipe Size	Outside Diam.	Diam. at Base of Hub	O.D of Raised Face	Thickness	BORE				LENGTH THRU HUB			Diam. of Hub at Bevel	Radius of Fillet	Thread Length
					Welding Neck	Slip-on	Lap Joint	Counter Bore Min.	Welding Neck	Slip-on Threaded	Lap Joint			
					B1	B2	B3	B	T1	T2	T3			
1/2	133	42.9	35.1	30.2	To be specified by purchaser.	22.4	22.9	23.6	73.2	39.6	39.6	21.3	3.0	28.4
3/4	140	50.8	42.9	31.8		27.7	28.2	29.0	79.2	42.9	42.9	26.7	3.0	31.8
1	159	57.2	50.8	35.1		34.5	35.1	35.8	88.9	47.8	47.8	33.5	3.0	35.1
1 1/4	184	73.2	63.5	38.1		43.2	43.7	44.5	95.3	52.3	52.3	42.2	4.8	38.1
1 1/2	203	79.2	73.2	44.5		49.5	50.0	50.5	111.3	60.5	60.5	48.3	6.4	44.5
2	235	95.3	91.9	50.8		62.0	62.5	63.5	127.0	69.9	69.9	60.5	7.9	50.8
2 1/2	267	114.3	104.6	57.2		74.7	75.4	76.2	142.7	79.2	79.2	73.2	7.9	57.2
3	305	133.4	127.0	66.5		90.7	91.4	92.2	168.1	91.9	91.9	88.9	9.7	63.5
4	356	165.1	157.2	76.2		116.1	116.8	117.6	190.5	108.0	108.0	114.3	11.2	69.9
5	419	203.2	185.7	91.9		143.8	144.5	144.5	228.6	130.0	130.0	141.2	11.2	76.2
6	483	235.0	215.9	108.0		170.7	171.5	171.5	273.1	152.4	152.4	168.4	12.7	82.6
8	552	304.8	269.7	127.0		221.5	222.3	222.3	317.5	177.8	177.8	219.2	12.7	95.3
10	673	374.7	323.9	165.1	276.4	277.4	276.4	419.1	228.6	228.6	273.1	12.7	108.0	
12	762	441.5	381.0	184.2	327.2	328.2	328.7	463.6	254.0	254.0	323.9	12.7	120.7	

## NOTE :

- For the 'Bore' (B1) other Standard Wall Thickness, refer to page 46,47
- Class 2500 flanges except Lap Joint will be furnished with 0.25" (6.35mm) raised face, which is included in 'Thickness' (t) and 'Length through Hub' (T1), (T2).
- For Slip-on, Threaded, Socket Welding and Lap Joint Flanges, the hubs can be shaped either vertical from base to top or tapered within the limits of 7 degrees.



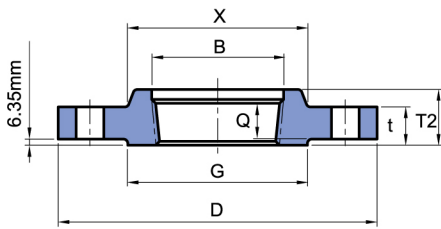

THREADED

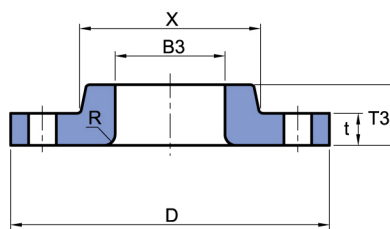

LAP JOINT

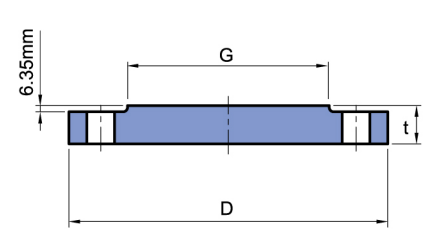

BLIND

Unit : mm

Nominal Pipe Size	DRILLING			BOLTING				APPROXIMATE WEIGHT							
	Bolt Circle Diam.	Number of Holes	Diam. of Holes	Diam. of Bolts (inch)	STUD BOLT LENGTH			Welding Neck		Slip-on and Threaded		Lap Joint		Blind	
					0.25" Raised Face	Male - Female Tongue - Groove	Ring Joint	Kg	lb	Kg	lb	Kg	lb	Kg	lb
1/2	88.9	4	22.4	3/4	120.7	114.3	120.7	3.18	7.00	3.18	7.00	3.00	6.60	3.18	7.00
3/4	95.3	4	22.4	3/4	127.0	120.7	127.0	4.08	9.00	4.08	9.00	3.63	8.00	4.54	10.00
1	108.0	4	25.4	7/8	139.7	133.4	139.7	5.45	12.00	5.44	12.00	4.99	11.00	5.44	12.00
1 1/4	130.0	4	28.4	1	152.4	146.1	152.4	9.07	20.00	8.16	18.00	7.26	16.00	8.16	18.00
1 1/2	146.1	4	31.8	1 1/8	171.5	165.1	171.5	11.35	25.00	11.00	24.30	9.99	22.00	10.44	23.00
2	171.5	8	28.4	1	177.8	171.5	177.8	19.07	42.00	17.25	38.00	16.80	37.00	17.71	39.00
2 1/2	196.9	8	31.8	1 1/8	196.9	190.5	203.2	23.61	52.00	24.97	55.00	24.06	53.00	25.42	56.00
3	228.6	8	35.1	1 1/4	222.3	215.9	228.6	42.68	94.00	37.68	83.00	36.32	80.00	39.04	86.00
4	273.1	8	41.1	1 1/2	254.0	247.7	260.4	64.00	141.00	58.00	127.90	54.48	120.00	60.38	133.00
5	323.9	8	47.8	1 3/4	298.5	292.1	311.2	110.68	244.00	95.25	210.00	92.53	204.00	101.15	223.00
6	368.3	8	53.8	2	342.9	336.6	355.6	176.46	378.00	146.51	323.00	143.01	315.30	156.63	345.30
8	438.2	12	53.8	2	381.0	374.7	393.7	261.27	576.00	219.99	485.00	213.38	470.40	240.62	530.50
10	539.8	12	66.5	2 1/2	489.0	482.6	508.0	484.43	1068.00	419.57	925.00	408.60	900.80	465.36	1026.00
12	619.3	12	73.2	2 3/4	539.8	533.4	558.8	692.35	1526.30	590.20	1301.00	572.95	1263.00	664.06	1464.00

- Blind Flanges may be made with the same hub as that used for Slip-on Flanges or without hub.
- The gasket surface and backside (bearing surface for bolting) are made parallel within 1 degree. To accomplish parallelism, spot facing is carried out according to MSS SP-9, without reducing thickness (t).
- Class 2500 Slip-on Flanges are not covered by ANSI B16.5, slip-on flanges are at the manufacture's option.





**PAP** PETRO ARTAN PART

# RING JOINT FLANGES

- Class 150 Flanges
- Class 300 / 400 / 600 Flanges
- Class 900 Flanges
- Class 1500 Flanges
- Class 2500 Flanges

# CLASS 150 FLANGES

## Ring Joint Flanges Facing Dimensions

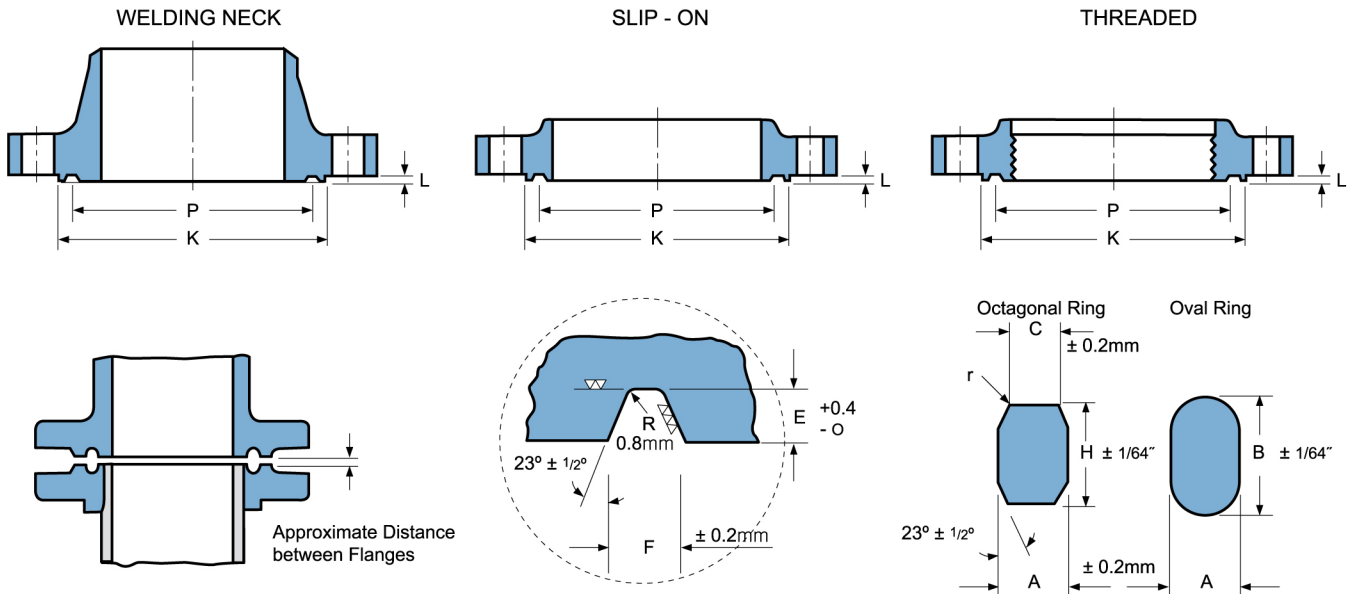

## ANSI B 16.5 Forged Flanges

Unit : mm

Nominal Pipe Size	Pitch Diam. of Ring and Groove	Width of Ring	HEIGHT OF RING		Width of Flat on Octagonal Rings	Width of Groove	Depth of Groove	Diameter of Raised Face for Ring Joint or Lapped	Ring Number	Approximate Distance Between Flange of Ring Joints When Ring is Compressed
			Oval	Octagonal						
	P	A	B	H	C	F	E(L*)	K(Min)		
1	47.6	8.0	14.3	12.7	5.2	8.7	6.4	63.5	R15	4.1
1 1/4	57.2	8.0	14.3	12.7	5.2	8.7	6.4	73.2	R17	4.1
1 1/2	65.1	8.0	14.3	12.7	5.2	8.7	6.4	82.6	R19	4.1
2	82.6	8.0	14.3	12.7	5.2	8.7	6.4	101.6	R22	4.1
2 1/2	101.6	8.0	14.3	12.7	5.2	8.7	6.4	120.7	R25	4.1
3	114.3	8.0	14.3	12.7	5.2	8.7	6.4	133.4	R29	4.1
3 1/2	131.8	8.0	14.3	12.7	5.2	8.7	6.4	153.9	R33	4.1
4	149.2	8.0	14.3	12.7	5.2	8.7	6.4	171.5	R36	4.1
5	171.5	8.0	14.3	12.7	5.2	8.7	6.4	193.5	R40	4.1
6	193.7	8.0	14.3	12.7	5.2	8.7	6.4	218.9	R43	4.1
8	247.7	8.0	14.3	12.7	5.2	8.7	6.4	273.1	R48	4.1
10	304.8	8.0	14.3	12.7	5.2	8.7	6.4	330.2	R52	4.1
12	381.0	8.0	14.3	12.7	5.2	8.7	6.4	406.4	R56	4.1
14	396.9	8.0	14.3	12.7	5.2	8.7	6.4	425.5	R59	3.0
16	454.0	8.0	14.3	12.7	5.2	8.7	6.4	482.6	R64	3.0
18	517.5	8.0	14.3	12.7	5.2	8.7	6.4	546.1	R68	3.0
20	558.8	8.0	14.3	12.7	5.2	8.7	6.4	596.9	R72	3.0
24	673.1	8.0	14.3	12.7	5.2	8.7	6.4	711.2	R76	3.0

**NOTE :**

- Unless other wise specified by the customer, Ring Type Joint Flanges will be furnished in accordance with these details.
- The depth of groove is added to the minimum flange thickness.
  - \* Raised face " L " is equal to groove dimension " E " but is not subject to tolerances for " E "
  - \* A plus tolerance of 3/64 in, for heights B and H is permitted providing the variation in the height of any given ring does not exceed 1/64 in, throughout its entire circumference.
- Dimension " R " is max.
- Radius " r " is 1/16" for ring widths 7/8" and less and 3/32" for ring widths 1"(25.4mm) and over.

## CLASS 300 / 400 / 600 FLANGES

### Ring Joint Flanges Facing Dimensions

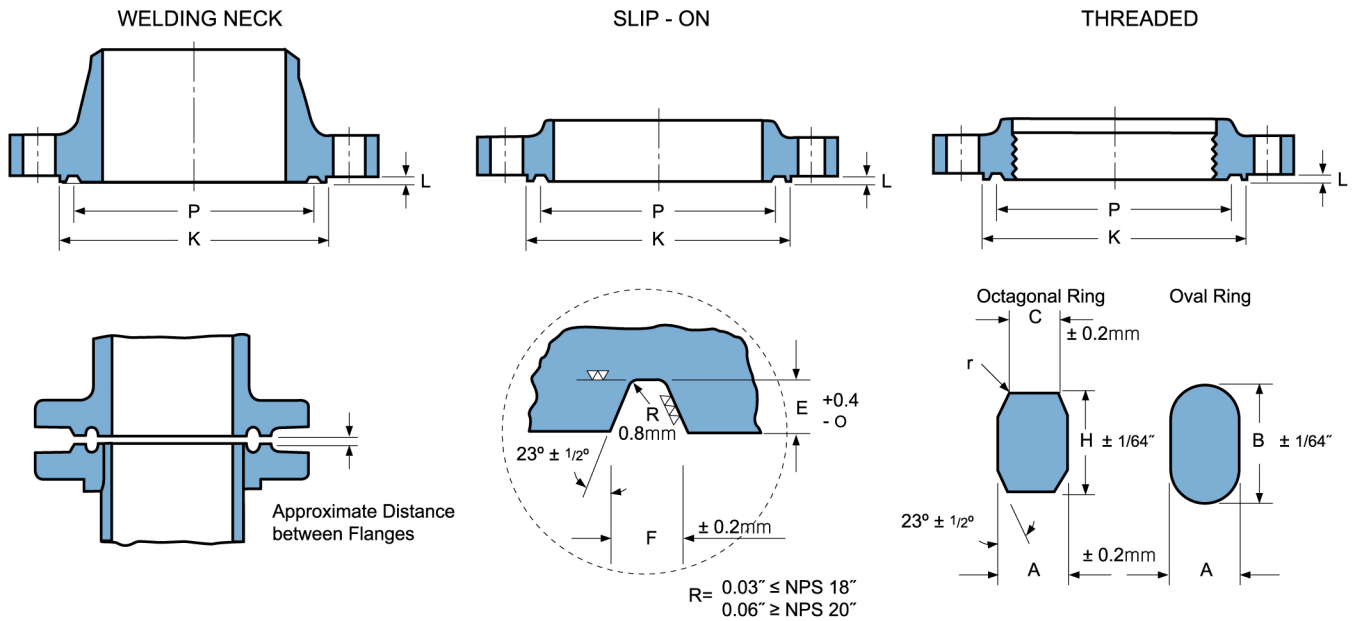

## ANSI B 16.5 Forged Flanges

Unit : mm

Nominal Pipe Size	Pitch Diam. of Ring and Groove	Width of Ring	HEIGHT OF RING		Width of Flat on Octagonal Rings	Width of Groove	Depth of Groove	Diameter of Raised Face for Ring Joint or Lapped	Ring Number	Approximate Distance Between Flange of Ring Joints When Ring is Compressed		
			Oval	Octagonal						Class 300	Class 400	Class 600
			B	H								
1/2	34.1	6.4	11.1	9.5	4.3	7.1	5.6	50.8	R11	3.0	-	3.0
3/4	42.9	8.0	14.3	12.7	5.2	8.7	6.4	63.5	R13	4.1	-	4.1
1	50.8	8.0	14.3	12.7	5.2	8.7	6.4	69.9	R16	4.1	-	4.1
1 1/4	60.3	8.0	14.3	12.7	5.2	8.7	6.4	79.5	R18	4.1	-	4.1
1 1/2	68.3	8.0	14.3	12.7	5.2	8.7	6.4	90.4	R20	4.1	-	4.1
2	82.6	11.1	17.5	15.9	7.7	11.9	7.9	108.0	R23	5.6	-	4.8
2 1/2	101.6	11.1	17.5	15.9	7.7	11.9	7.9	127.0	R26	5.6	-	4.8
3	123.8	11.1	17.5	15.9	7.7	11.9	7.9	146.1	R31	5.6	-	4.8
3 1/2	131.8	11.1	17.5	15.9	7.7	11.9	7.9	158.8	R34	5.6	-	4.8
4	149.2	11.1	17.5	15.9	7.7	11.9	7.9	174.8	R37	5.6	5.6	4.8
5	181.0	11.1	17.5	15.9	7.7	11.9	7.9	209.6	R41	5.6	5.6	4.8
6	211.2	11.1	17.5	15.9	7.7	11.9	7.9	241.3	R45	5.6	5.6	4.8
8	269.9	11.1	17.5	15.9	7.7	11.9	7.9	301.8	R49	5.6	5.6	4.8
10	323.9	11.1	17.5	15.9	7.7	11.9	7.9	355.6	R53	5.6	5.6	4.8
12	381.0	11.1	17.5	15.9	7.7	11.9	7.9	412.8	R57	5.6	5.6	4.8
14	419.1	11.1	17.5	15.9	7.7	11.9	7.9	457.2	R61	5.6	5.6	4.8
16	469.9	11.1	17.5	15.9	7.7	11.9	7.9	508.0	R65	5.6	5.6	4.8
18	533.4	11.1	17.5	15.9	7.7	11.9	7.9	574.8	R69	5.6	5.6	4.8
20	584.2	12.7	19.1	17.5	8.7	13.5	9.5	635.0	R73	5.6	5.6	4.8
24	692.2	15.9	22.2	20.7	10.5	16.7	11.1	749.3	R77	6.4	6.4	5.6

NOTE :

- Unless other wise specified by the customer, Ring Type Joint Flanges will be furnished in accordance with these details.
- The depth of groove is added to the minimum flange thickness.
  - \* Raised face " L " is equal to groove dimension " E " but is not subject to tolerances for " E "
  - \* A plus tolerance of 3/64 in, for heights B and H is permitted providing the variation in the height of any given ring does not exceed 1/64 in, throughout its entire circumference.
- Dimension " R " is max.
- Radius " r " is 1/16" for ring widths 7/8" and less and 3/32" for ring widths 1"(25.4mm) and over.

# CLASS 900 FLANGES

## Ring Joint Flanges Facing Dimensions

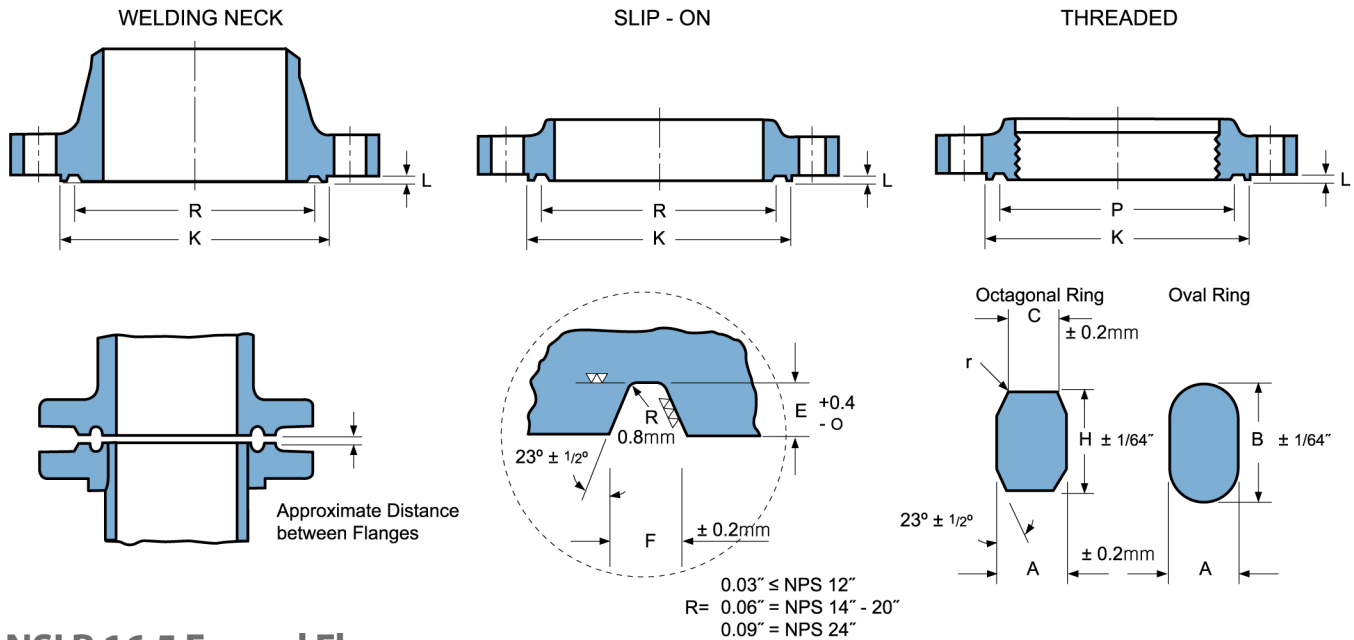

## ANSI B 16.5 Forged Flanges

Unit : mm

Nominal Pipe Size	Pitch Diam. of Ring and Groove	Width of Ring	HEIGHT OF RING		Width of Flat on Octagonal Rings	Width of Groove	Depth of Groove	Diameter of Raised Face for Ring Joint or Lapped	Ring Number	Approximate Distance Between Flange of Ring Joints When Ring is Compressed
			Oval	Octagonal						
	P	A	B	H	C	F	E(L*)	K(Min)		

For size 2 1/2 and smaller, use Class 1500 Ring Joint Flanges

3	123.8	11.1	17.5	15.9	7.7	11.9	7.9	155.4	R31	4.1
4	149.2	11.1	17.5	15.9	7.7	11.9	7.9	180.8	R37	4.1
5	181.0	11.1	17.5	15.9	7.7	11.9	7.9	215.9	R41	4.1
6	211.2	11.1	17.5	15.9	7.7	11.9	7.9	241.3	R45	4.1
8	269.9	11.1	17.5	15.9	7.7	11.9	7.9	307.8	R49	4.1
10	323.9	11.1	17.5	15.9	7.7	11.9	7.9	362.0	R53	4.1
12	381.0	11.1	17.5	15.9	7.7	11.9	7.9	419.1	R57	4.1
14	419.1	15.9	22.2	20.7	10.5	16.7	11.1	466.9	R62	4.1
16	469.9	15.9	22.2	20.7	10.5	16.7	11.1	523.7	R66	4.1
18	533.4	19.1	25.4	23.8	11.1	19.8	12.7	593.9	R70	4.8
20	584.2	19.1	25.4	23.8	12.3	19.8	12.7	647.7	R74	4.8
24	692.2	25.4	33.4	31.8	17.3	27.0	15.9	771.7	R78	5.6

**NOTE :**

1. Unless other wise specified by the customer, Ring Type Joint Flanges will be furnished in accordance with these details.
2. The depth of groove is added to the minimum flange thickness.
  - \* Raised face " L " is equal to groove dimension " E " but is not subject to tolerances for " E "
  - \* A plus tolerance of 3/64 in, for heights B and H is permitted providing the variation in the height of any given ring does not exceed 1/64 in, throughout its entire circumference.
3. Dimension " R " is max.
4. Radius " r " is 1/16" for ring widths 7/8" and less and 3/32" for ring widths 1"(25.4mm) and over.

# CLASS 1500 FLANGES

## Ring Joint Flanges Facing Dimensions

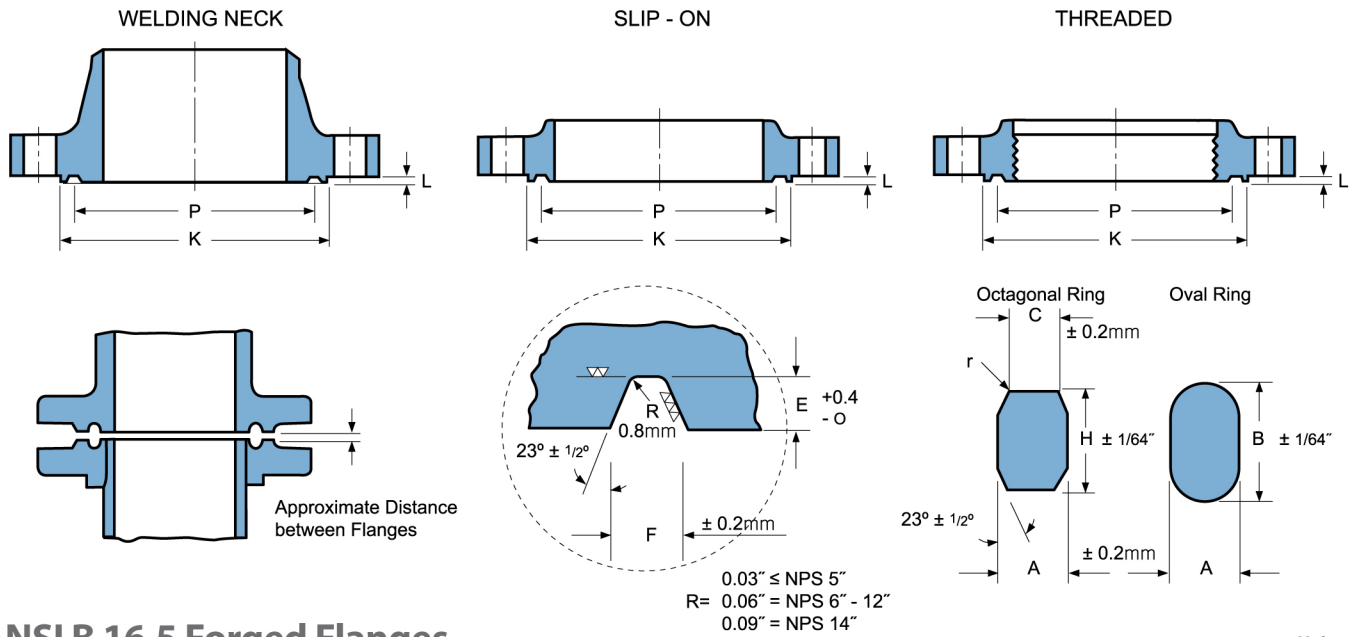

## ANSI B 16.5 Forged Flanges

Unit : mm

Nominal Pipe Size	Pitch Diam. of Ring and Groove	Width of Ring	HEIGHT OF RING		Width of Flat on Octagonal Rings	Width of Groove	Depth of Groove	Diameter of Raised Face for Ring Joint or Lapped	Ring Number	Approximate Distance Between Flange of Ring Joints When Ring is Compressed
			Oval	Octagonal						
	P	A	B	H	C	F	E(L*)	K(Min)		
1/2	39.7	8.0	14.3	12.7	5.2	8.7	6.4	60.5	R12	4.1
3/4	44.5	8.0	14.3	12.7	5.2	8.7	6.4	66.8	R14	4.1
1	50.8	8.0	14.3	12.7	5.2	8.7	6.4	71.4	R16	4.1
1 1/4	60.3	8.0	14.3	12.7	5.2	8.7	6.4	81.0	R18	4.1
1 1/2	68.3	8.0	14.3	12.7	5.2	8.7	6.4	92.2	R20	4.1
2	95.3	11.1	17.5	15.9	7.7	11.9	7.9	124.0	R24	3.0
2 1/2	108.0	11.1	17.5	15.9	7.7	11.9	7.9	136.7	R27	3.0
3	136.5	11.1	17.5	15.9	7.7	11.9	7.9	168.4	R35	3.0
4	161.9	11.1	17.5	15.9	7.7	11.9	7.9	193.8	R39	3.0
5	193.7	11.1	17.5	15.9	7.7	11.9	7.9	228.6	R44	3.0
6	211.2	12.7	19.1	17.5	8.7	13.5	9.5	247.7	R46	3.0
8	269.9	15.9	22.2	20.7	10.5	16.7	11.1	317.5	R50	4.1
10	323.9	15.9	22.2	20.7	10.5	16.7	11.1	371.6	R54	4.1
12	381.0	22.2	28.6	27.0	14.8	23.0	14.3	438.2	R58	4.8
14	419.1	25.4	33.4	31.8	17.3	27.0	15.9	489.0	R64	5.6
16	469.9	28.6	36.5	34.9	19.8	30.2	17.5	546.1	R67	7.9
18	533.4	28.6	36.5	34.9	19.8	30.2	17.5	612.9	R71	7.9
20	584.2	31.8	39.7	38.1	22.3	33.4	17.5	673.1	R75	9.7
24	692.2	34.9	44.5	41.3	24.8	36.5	20.6	793.8	R79	11.2

**NOTE :**

1. Unless other wise specified by the customer, Ring Type Joint Flanges will be furnished in accordance with these details.
2. The depth of groove is added to the minimum flange thickness.
  - \* Raised face "L" is equal to groove dimension "E" but is not subject to tolerances for "E"
  - \* A plus tolerance of 3/64 in, for heights B and H is permitted providing the variation in the height of any given ring does not exceed 1/64 in, throughout its entire circumference.
3. Dimension "R" is max.
4. Radius "r" is 1/16" for ring widths 7/8" and less and 3/32" for ring widths 1"(25.4mm) and over.



# CLASS 2500 FLANGES

## Ring Joint Flanges Facing Dimensions

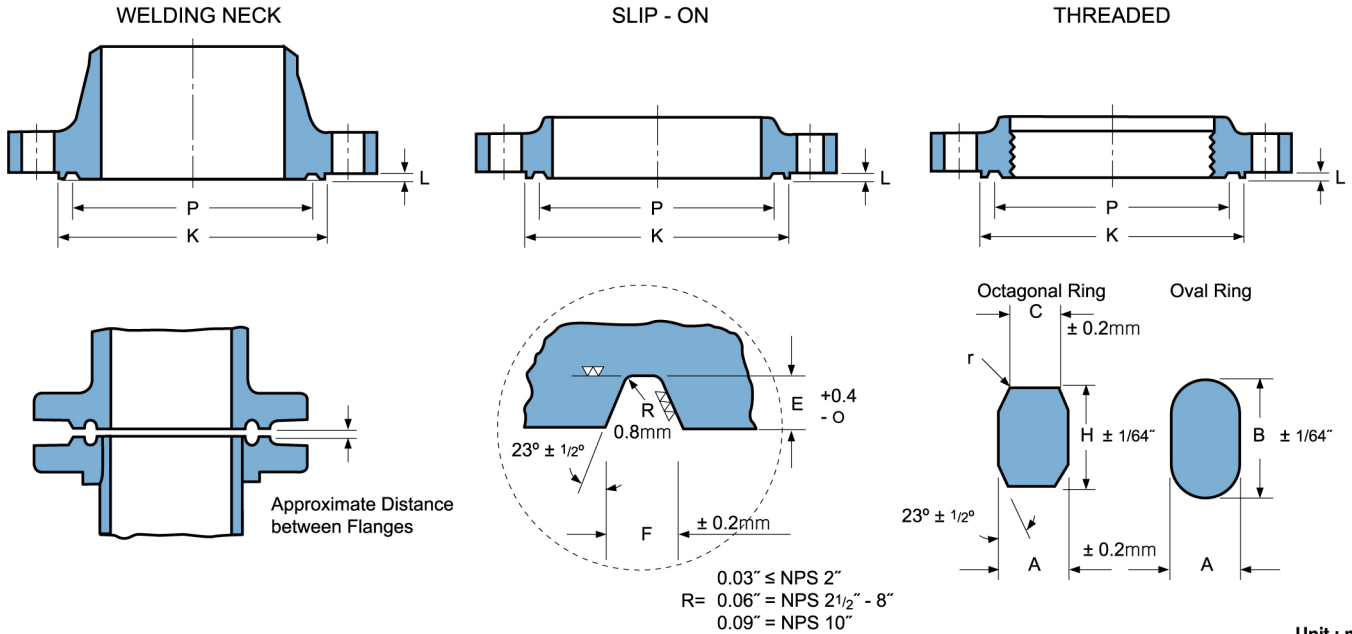

Unit : mm

Nominal Pipe Size	Pitch Diam. of Ring and Groove	Width of Ring	HEIGHT OF RING		Width of Flat on Octagonal Rings	Width of Groove	Depth of Groove	Diameter of Raised Face for Ring Joint or Lapped	Ring Number	Approximate Distance Between Flange of Ring Joints When Ring is Compressed
			Oval	Octagonal						
			B	H						
1/2	42.9	8.0	14.3	12.7	5.2	8.7	6.4	65.0	R13	4.1
3/4	50.8	8.0	14.3	12.7	5.2	8.7	6.4	73.2	R16	4.1
1	60.3	8.0	14.3	12.7	5.2	8.7	6.4	82.6	R18	4.1
1 1/4	72.2	11.1	17.5	15.9	7.7	11.9	7.9	101.6	R21	3.0
1 1/2	82.6	11.1	17.5	15.9	7.7	11.9	7.9	114.3	R23	3.0
2	101.6	11.1	17.5	15.9	7.7	11.9	7.9	133.4	R26	3.0
2 1/2	111.1	12.7	19.1	17.5	8.7	13.5	9.5	149.4	R28	3.0
3	127.0	12.7	19.1	17.5	8.7	13.5	9.5	168.4	R32	3.0
4	157.2	15.9	22.2	20.7	10.5	16.7	11.1	203.2	R38	4.1
5	190.5	19.1	25.4	23.8	12.3	19.8	12.7	241.3	R42	4.1
6	228.6	19.1	25.4	23.8	12.3	19.8	12.7	279.4	R47	4.1
8	279.4	22.2	28.6	27.0	14.8	23.0	14.3	339.9	R51	4.8
10	342.9	28.6	36.5	34.9	19.8	30.2	17.5	425.5	R55	6.4
12	406.4	31.8	39.7	38.1	22.3	33.4	17.5	495.3	R60	7.9

**NOTE :**

- Unless other wise specified by the customer, Ring Type Joint Flanges will be furnished in accordance with these details.
- The depth of groove is added to the minimum flange thickness.
  - \* Raised face " L " is equal to groove dimension " E " but is not subject to tolerances for " E "
  - \* A plus tolerance of 3/64 in, for heights B and H is permitted providing the variation in the height of any given ring does not exceed 1/64 in, throughout its entire circumference.
- Dimension " R " is max.
- Radius " r " is 1/16" for ring widths 7/8" and less and 3/32" for ring widths 1"(25.4mm) and over.



**PAP** PETRO ARTAN PART

# ORIFICE FLANGES

- ANSI Orifice Flanges
- Class 300 Flanges
- Class 400 Flanges
- Class 600 Flanges
- Class 900 Flanges
- Class 1500 Flanges
- Class 2500 Flanges

# ANSI ORIFICE FLANGES

## (ANSI B16.36) Forged Flanges

ORIFICE FLANGES are widely used in conjunction with orifice meters for measuring the rate of flow of liquids and gases. They are basically the same as standard welding neck, slip-on and screwed flanges except for the provision of radial, tapped holes in the flange ring for meter connections and additional bolts to act as jack screws to facilitate separating the flanges for inspection or replacement of the orifice plate.

### NOTES :

#### ■ JACK SCREW PROVISION

- (1) Each Flange shall have a machine bolt mounted in a hole drilled on the flange centerline at 90 deg. from the pressure taps, for use as a jackscrew. Machine bolt shall be regular, with one heavy hex, nut.
- (2) A slot shall be provided in the flange 0.06 in. (1.6mm) wider than the width across flats of the nut. The depth of the slot shall admit the nut so that there is no interference with the joining of the flanges when bolted together without orifice plate.

#### ■ PRESSURE TAPS

- (1) Each orifice flange is provided with two pressure tap holes extending radially from the outside diameter of the flange to the inside diameter of the flange. Corner taps may be used on NPS 1 1/2 and smaller if space permits. Each pressure tap hole shall be equipped with a pipe plug.
- (2) The 0.94 in. (23.8) locating dimension for raised face and 0.75 in. (19.1mm) for ring joint shall be measured at the bore.
- (3) Each pressure tap hole shall be equipped with a pipe plug.

#### ■ FACING

The finish of Contact Faces Shall Conform to the Requirements of ASME / ANSI B 16.5

#### ■ FLANGE THREADS

- (1) Threaded flanges shall have an American National Standard taper pipe thread conforming to ANSI B 2.1
- (2) The thread shall be concentric with the axis of the flange and variations in alignment shall not exceed 0.06 in (1.6mm) per foot.
- (3) The flanges are made with counterbored at the back of the flange and the threads shall be chamfered to the diameter of the counterbore at an angle of approximately 45 degrees with the axis of the thread to afford easy entrance in making a joint. The chamfer shall be concentric with the thread.
- (4) In order to permit the pipe to be inserted to the flange, the threads should have full root diameters through to the face of the flange, or shall have a counterbore at the face of the flange.
- (5) The gaging notch of the working gage shall come flush with the bottom of the chamfer in all threaded flanges and shall be considered as being the intersection of the chamfer cone and the pitch cone of the thread. This depth of chamfer is approximately equal to 1/2 of the pitch of the thread.
- (6) The maximum allowable thread variation is one turn large or small from the gaging notch.

#### ■ TOLERANCES

Tolerances on all dimensions shall be as shown ANSI B16.5 except for those shown below.

- (1) Tolerance on location of center of pressure tap hole from flange face shall be :
  - a. Flanges smaller than nominal size  $4 \pm 0.02$  in (0.5mm)
  - b. Flanges nominal size 4 and larger  $\pm 0.03$  in (0.8mm)
- (2) Bore diameter tolerance (welding neck flanges only) is  $\pm 0.5\%$  of nominal value.

**CLASS 300 ORIFICE FLANGES**

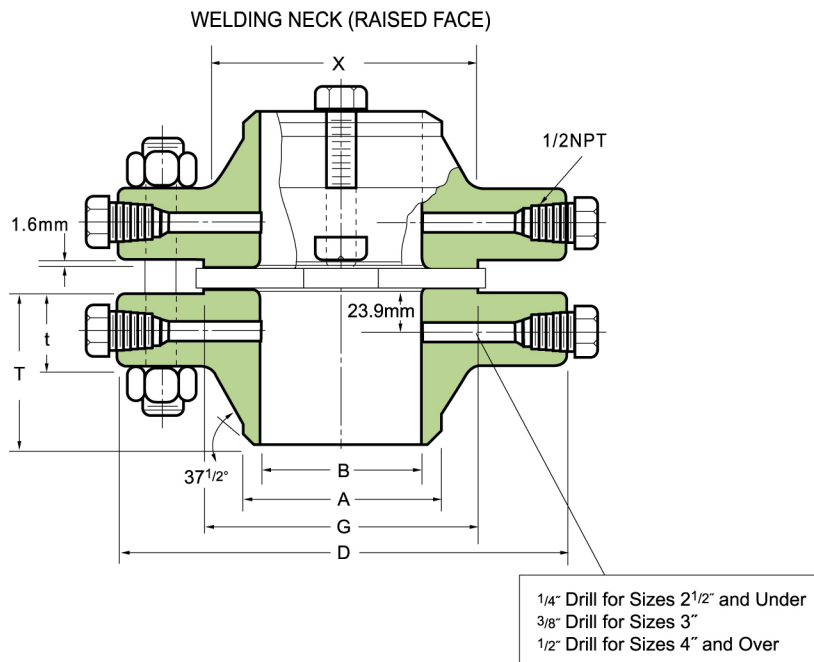

**ANSI B 16.36 Forged Flanges**

Unit : mm

Nominal Pipe Size	Outside Diam. of Flange <b>D</b>	THICKNESS OF FLANGE (t) Raised Face	Diam. of Hub at Base <b>X</b>	Diam. of Raised Base <b>G</b>	Diam. of Hub of Bevel <b>A</b>	LENGTH THRU HUB (T)		BORE (B)	
						Welding Neck Raised Face	Slip-on & Threaded Raised Face	Welding Neck	Slip-on
		1				124	38.1	53.8	50.8
1 1/4	133	38.1	63.5	63.5	42.2	84.1	46.0	35.1	43.2
1 1/2	155	38.1	69.9	73.2	48.3	85.9	47.8	40.9	49.5
2	165	38.1	84.1	91.9	60.5	85.9	49.3	52.6	62.0
2 1/2	191	38.1	100.1	104.6	73.2	88.9	50.8	62.7	74.7
3	210	38.1	117.3	127.0	88.9	88.9	52.3	78.0	90.7
4	254	38.1	146.1	157.2	114.3	91.9	53.8	102.4	116.1
5	279	38.1	177.8	185.7	141.2	101.6	53.8	128.3	143.8
6	318	38.1	206.2	215.9	168.4	100.1	53.8	154.2	170.7
8	381	41.1	260.4	269.7	219.2	111.3	62.0	202.7	221.5
10	445	47.8	320.5	323.9	273.1	117.3	66.5	254.5	276.4
12	521	50.8	374.7	381.0	323.9	130.0	73.2	304.8	327.2
14	584	53.8	425.5	412.8	355.6	142.7	76.2	336.6	359.2
16	648	57.2	482.6	469.9	406.4	146.1	82.6	387.4	410.5
18	711	60.5	533.4	533.4	457.2	158.8	88.9	438.2	461.8
20	775	63.5	587.2	584.2	508.0	162.1	95.3	489.0	513.1
24	914	69.9	701.5	692.2	609.6	168.1	106.4	590.6	616.0

NOTE :

1. For the 'Bore' (B) of Welding Neck Flanges other than Standard Wall Thickness, refer to 46.47
2. Class 300 Welding Neck Flanges of sizes 24" (609.6mm) and smaller will be bored to match Standard Wall Pipe unless otherwise specified.
3. Class 300 Orifice Flanges will be furnished with 0.06" (1.6mm) raised face, which is included in 'Thickness' (t) and 'Length through Hub' (T)
4. Bolt lengths for raised face flanges include allowance for orifice and gasket thickness of 0.25" (6.4mm) for NPS 1-12 and 0.38" (9.7mm) for sizes 14-24



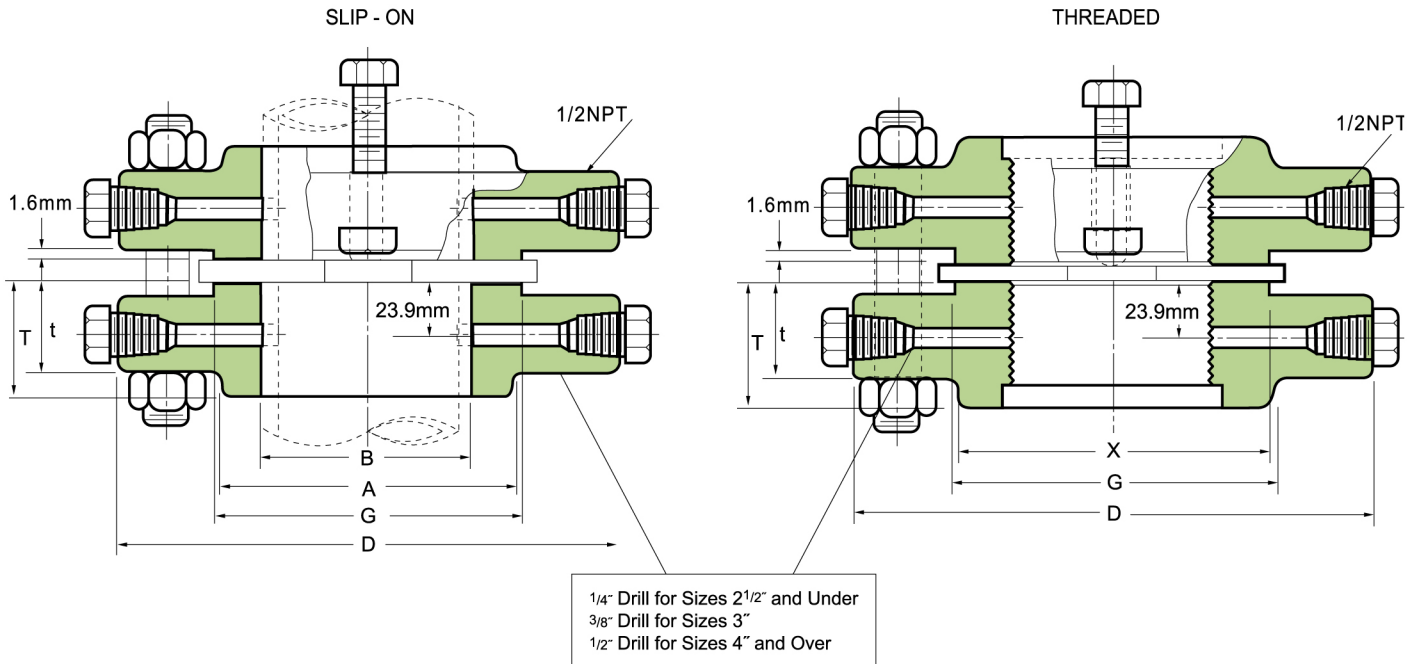

Unit : mm

Nominal Pipe Size	Pitch Diam. of Ring and Groove <b>P</b>	Ring Number	DEPTH OF JACK SCREW SLOT		DRILLING TEMPLATE				
			Raised Face	JACK SCREW SIZE Raised Face	Diam. of Bolt Circle	Number of Bolts	Diam. of Stud Bolts (inch)	Diam. of Bolts Holes	Length of Stud Bolts Raised Face
1	50.8	R16	9.7	Jack screw size for 1 thru 24 are those shown for length and diameter of bolts.	88.9	4	5/8	17.5	139.7
1 1/4	60.3	R18	9.7		98.6	4	5/8	17.5	152.4
1 1/2	68.3	R20	12.7		114.3	4	3/4	20.6	152.4
2	82.6	R23	9.7		127.0	8	5/8	17.5	152.4
2 1/2	101.6	R26	12.7		149.4	8	3/4	20.6	152.4
3	123.8	R31	12.7		168.1	8	3/4	20.6	152.4
4	149.2	R37	12.7		200.2	8	3/4	20.6	152.4
5	181.0	R41	12.7		235.0	8	3/4	22.4	152.4
6	211.1	R45	12.7		269.7	12	3/4	22.4	152.4
8	269.9	R49	15.7		330.2	12	7/8	25.4	158.8
10	323.9	R53	19.1		387.4	16	1	28.4	165.1
12	381.0	R57	22.4		450.9	16	1 1/8	31.8	177.8
14	419.1	R61	22.4		514.4	20	1 1/8	31.8	184.2
16	469.9	R65	25.4		571.5	20	1 1/4	35.1	196.9
18	533.4	R69	25.4		628.7	24	1 1/4	35.1	203.2
20	584.2	R73	25.4		685.8	24	1 1/4	35.1	215.9
24	692.2	R77	31.8		812.8	24	1 1/2	41.1	241.3

NOTE :

5. Unless otherwise specified, unions of 1 (25.4mm) thru 24 (609.6mm) furnished with carbon steel regular square headed bolts with semifinished American Standard heavy series hex nuts.

# CLASS 400 ORIFICE FLANGES

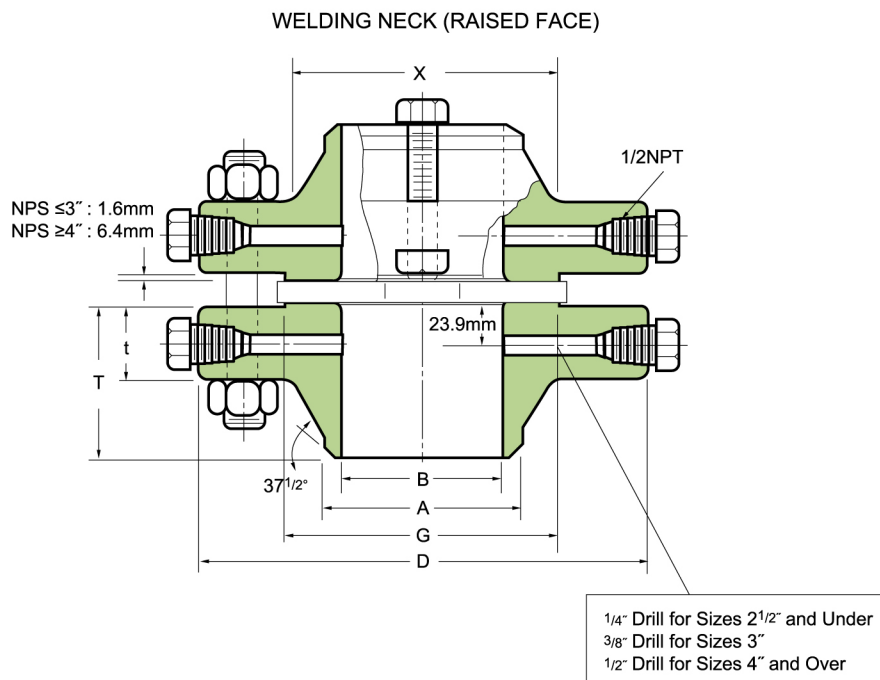

## ANSI B 16.36 Forged Flanges

Unit : mm

Nominal Pipe Size	Outside Diam. of Flange D	THICKNESS OF FLANGE (t)		Diam. of Hub at Base X	Diam. of Raised Base G	Diam. of Hub of Bevel A	LENGTH THRU HUB (T)				BORE (B)	
		Raised Face	Ring Joint				Welding Neck		Slip-on & Threaded		Welding Neck	Slip-on
							Raised Face	Ring Joint	Raised Face	Ring Joint		
1	124	38.1	31.8	53.8	50.8	33.5	82.6	76.2	47.8	41.1	See Note 1. To be specified by purchaser	34.5
1 1/4	133	38.1	31.8	63.5	63.5	42.2	84.1	77.7	46.0	39.6		43.2
1 1/2	155	38.1	31.8	69.9	73.2	48.3	85.9	79.2	47.8	41.1		49.5
2	165	38.1	31.8	84.1	91.9	60.5	85.9	79.2	49.3	42.9		62.0
2 1/2	191	38.1	31.8	100.1	104.6	73.2	88.9	82.6	50.8	44.5		74.7
3	210	38.1	31.8	117.3	127.0	88.9	88.9	82.6	52.3	46.0		90.7
4	254	35.1	35.1	146.1	157.2	114.3	88.9	88.9	50.8	50.8		116.1
5	279	38.1	38.1	177.8	185.7	141.2	101.6	101.6	53.8	53.8		143.8
6	318	41.1	41.1	206.2	215.9	168.4	103.1	103.1	57.2	57.2		170.7
8	381	47.8	47.8	260.4	269.7	219.2	117.3	117.3	68.3	68.3		221.5
10	445	53.8	53.8	320.5	323.9	273.1	124.0	124.0	73.2	73.2		276.4
12	521	57.2	57.2	374.7	381.0	323.9	136.7	136.7	79.2	79.2		327.2
14	584	60.7	60.7	425.5	412.8	355.6	149.4	149.4	-	-		359.2
16	648	63.5	63.5	482.6	469.9	406.4	152.4	152.4	-	-		410.5
18	711	66.5	66.5	533.4	533.4	457.2	165.1	165.1	-	-		461.8
20	775	69.9	69.9	587.2	584.2	508.0	168.1	168.1	-	-		513.1
24	914	76.2	76.2	701.5	692.2	609.6	174.8	174.8	-	-		564.4

NOTE :

- For the inside diameter of pipes (corresponding to 'Bore' (B) of Welding Neck Flanges), refer to page 46,47
- Class 400 Flanges of sizes 3" and smaller will be furnished with 0.06" (1.6mm) raised face, which is included in 'Thickness' (t) and 'Length through Hub' (T)  
The 0.25" (6.35mm) raised face for sizes 4" and larger is not included in (t) and (T)
- Each union includes two carbon steel jack screw bolts with hex nuts.

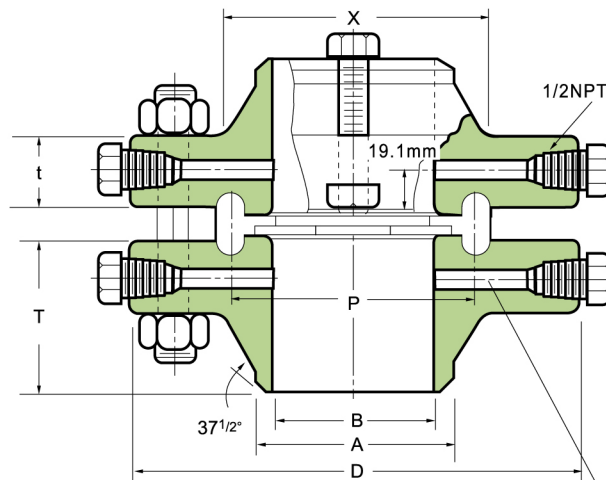
**WELDING NECK (RING-TYPE JOINT)**

1/4" Drill for Sizes 2 1/2" and Under  
 3/8" Drill for Sizes 3"  
 1/2" Drill for Sizes 4" and Over

Unit : mm

Nominal Pipe Size	Pitch Diam. of Ring and Groove <b>P</b>	Ring Number	DEPTH OF JACK SCREW SLOT		JACK SCREW SIZE		DRILLING TEMPLATE					
			Raised Face	Ring Joint	Raised Face (inch)	Ring Joint (inch)	Diam. of Bolt Circle	Number of Bolts	Diam. of Stud Bolts (inch)	Diam. of Bolts Holes	Length of Stud Bolts	
											Raised Face	Ring Joint
1	50.8	R16	9.7	6.4	5/8X4.00	5/8X4.75	88.9	4	5/8	17.5	127.0	146.1
1 1/4	60.3	R18	9.7	6.4	5/8X4.00	5/8X4.75	98.6	4	5/8	17.5	127.0	120.7
1 1/2	68.3	R20	12.7	6.4	3/4X4.25	3/4X5.00	114.3	4	3/4	21.0	133.4	152.4
2	82.6	R23	9.7	6.4	5/8X4.00	5/8X4.75	127.0	8	5/8	17.5	127.0	152.4
2 1/2	101.6	R26	12.7	6.4	3/4X4.25	3/4X5.00	149.4	8	3/4	20.6	133.4	158.8
3	123.8	R31	12.7	6.4	3/4X4.25	3/4X5.00	168.1	8	3/4	20.6	133.4	158.8
4	149.2	R37	6.4	15.7	3/4X3.00	3/4X4.00	200.2	8	7/8	25.4	139.7	152.4
5	181.0	R41	6.4	15.7	3/4X3.00	3/4X4.00	235.0	8	7/8	25.4	146.1	158.8
6	211.1	R45	12.7	22.4	1X3.50	1X4.00	269.7	12	7/8	25.4	158.8	165.1
8	269.9	R49	12.7	22.4	1X3.50	1X4.50	330.2	12	1	28.4	171.5	184.2
10	323.9	R53	12.7	22.4	1X4.00	1X4.50	387.4	16	1 1/8	31.8	190.5	203.2
12	381.0	R57	12.7	22.4	1X4.00	1X5.00	450.9	16	1 1/4	35.1	203.2	215.9
14	419.1	R61	12.7	22.4	1X4.25	1X5.00	514.4	20	1 1/4	35.1	209.6	228.6
16	469.9	R65	12.7	22.4	1X4.25	1X5.00	571.5	20	1 3/8	38.1	222.3	235.0
18	533.4	R69	12.7	22.4	1X4.50	1X5.00	628.7	24	1 3/8	38.1	235.0	241.3
20	584.2	R73	12.7	22.4	1X4.75	1X5.50	685.8	24	1 1/2	41.1	247.7	260.4
24	692.2	R77	12.7	22.4	1X5.00	1X6.00	812.8	24	1 3/4	47.8	279.4	285.8

**NOTE :**

- Unless otherwise specified, raised face unions are furnished with alloy bolt studs per ASTM A193 Grade B7 with American Standard heavy series hex nuts ASTM A194 Class 2H.
- On ring joint flanges having a groove depth 0.375" (9.5mm) and less, the distance from the center line of the tap hole to the flange face is 0.750" (19.1mm). When the depth of groove is 0.438" (11.1mm) or greater, changes in drill size or method of drilling are necessary.
- Bolt lengths for raised face flanges include allowance for orifice and gasket thickness of 0.25" (6.4mm) for sizes 4-12 and 0.38" (9.7mm) for sizes 14-24. Bolt lengths for ring type joint flanges include allowance of 0.62" (15.7mm) for sizes 4-10, 0.75" (19.1mm) for sizes 12-18 and 0.88" (22.4mm) for size 20.

# CLASS 600 ORIFICE FLANGES

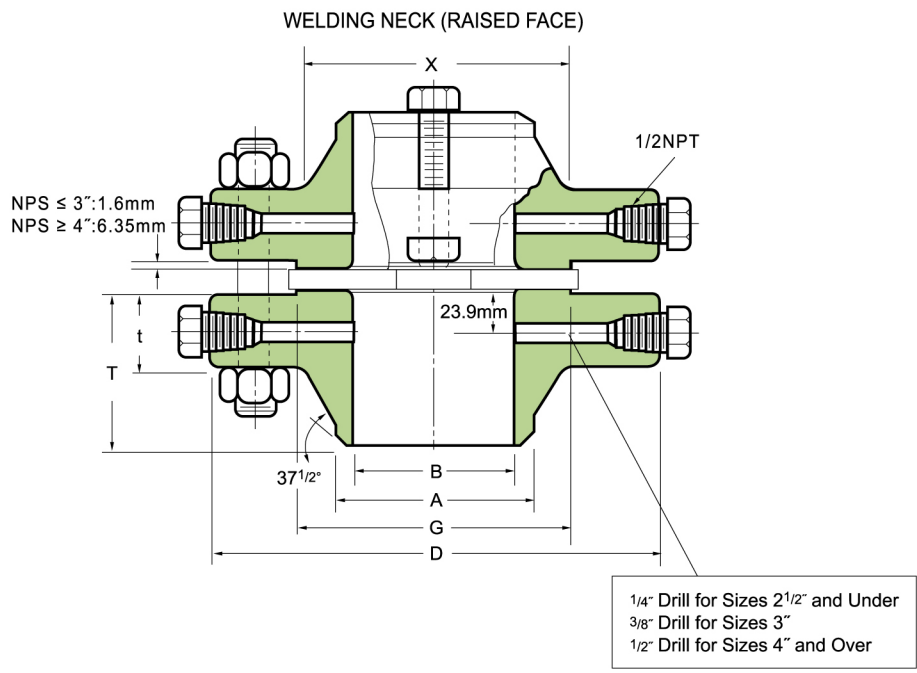

## ANSI B 16.36 Forged Flanges

Unit : mm

Nominal Pipe Size	Outside Diam. of Flange D	THICKNESS OF FLANGE (t)		Diam. of Hub at Base X	Diam. of Raised Base G	Diam. of Hub of Bevel A	LENGTH THRU HUB (T)				BORE (B)	
		Raised Face	Ring Joint				Welding Neck		Slip-on & Threaded		Welding Neck	Slip-on
							Raised Face	Ring Joint	Raised Face	Ring Joint		
1	124	38.1	31.8	53.8	50.8	33.5	82.6	76.2	47.8	41.1	See Note 1. To be specified by purchaser	34.5
1 1/4	133	38.1	31.8	63.5	63.5	42.2	84.1	77.7	46.0	39.6		43.2
1 1/2	155	38.1	31.8	69.9	73.2	48.3	85.9	79.2	47.8	41.1		49.5
2	165	38.1	31.8	84.1	91.9	60.5	85.9	79.2	49.3	42.9		62.0
2 1/2	191	38.1	31.8	100.1	104.6	73.2	88.9	82.6	50.8	44.5		74.7
3	210	38.1	31.8	117.3	127.0	88.9	88.9	82.6	52.3	46.0		90.7
4	273	38.1	38.1	152.4	157.2	114.3	101.6	101.6	53.8	53.8		116.1
5	330	44.5	44.5	189.0	185.7	141.2	114.3	114.3	60.5	60.5		143.8
6	356	47.8	47.8	222.3	215.9	168.4	117.3	117.3	66.5	66.5		170.7
8	419	55.6	55.6	273.1	269.7	219.2	133.4	133.4	76.5	76.2		221.5
10	508	63.5	63.5	342.9	323.9	273.1	152.4	152.4	85.9	85.9		276.4
12	559	66.5	66.5	400.1	381.0	323.9	155.4	155.4	91.9	91.9		327.2
14	603	69.9	69.9	431.8	412.8	355.6	165.4	165.1	-	-		-
16	686	76.2	76.2	495.3	469.9	406.4	177.8	177.8	-	-		-
18	743	82.6	82.6	546.1	533.4	457.2	184.2	184.2	-	-		-
20	813	88.9	88.9	609.6	584.2	508.0	190.5	190.5	-	-		-
24	940	101.6	101.6	717.6	692.2	609.6	203.2	203.2	-	-		-

NOTE :

- For the inside diameter of pipes (corresponding to 'Bore' (B) of Welding Neck Flanges), refer to page 46,47
- Class 600 Flanges of sizes 3" and smaller will be furnished with 0.06" (1.6mm) raised face, which is included in 'Thickness' (t) and 'Length through Hub' (T) The 0.25" (6.35mm) raised face for sizes 4" and larger is not included in (t) and (T)
- Each union includes two carbon steel jack screw bolts with hex nuts.
- Bolt lengths for raised face flanges include allowance for orifice and gasket thickness of 0.25" (6.4mm) for sizes 1-12 and 0.38" (9.7mm) for sizes 14-24. Bolt lengths for ring type joint flanges include allowance of 0.62" (15.7mm) for sizes 1-10, 0.75" (19.1mm) for sizes 12-18 and 0.88" (22.4mm) for size 20.



WELDING NECK (RING-TYPE JOINT)

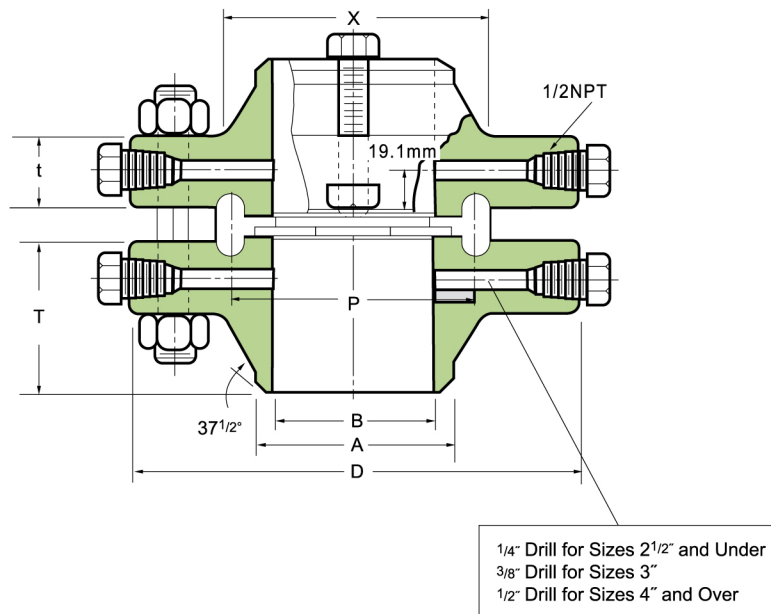

Unit : mm

Nominal Pipe Size	Pitch Diam. of Ring and Groove  P	Ring Number	DEPTH OF JACK SCREW SLOT		JACK SCREW SIZE		DRILLING TEMPLATE						
			Raised Face	Ring Joint	Raised Face (inch)	Ring Joint (inch)	Diam. of Bolt Circle	Number of Bolts	Diam. of Stud Bolts (inch)	Diam. of Stud Bolts Holes		Length of Stud Bolts	
										RF	RTJ	Raised Face	Ring Joint
1	50.8	R16	9.7	6.4	5/8X4.00	5/8X4.75	88.9	4	5/8	17.5	19.1	127.0	146.1
1 1/4	60.3	R18	9.7	6.4	5/8X4.00	5/8X4.75	98.6	4	5/8	17.5	-	127.0	120.7
1 1/2	68.3	R20	12.7	6.4	3/4X4.25	3/4X5.00	114.3	4	3/4	20.6	22.4	133.4	152.4
2	82.6	R23	9.7	6.4	5/8X4.00	5/8X4.75	127.0	8	5/8	17.5	19.7	127.0	152.4
2 1/2	101.6	R26	12.7	6.4	3/4X4.25	3/4X5.00	149.4	8	3/4	20.6	22.4	133.4	158.8
3	123.8	R31	12.7	6.4	3/4X4.25	3/4X5.00	168.1	8	3/4	20.6	22.4	133.4	158.8
4	149.2	R37	6.4	15.7	3/4X3.00	3/4X4.00	215.9	8	7/8	25.4	25.4	152.4	165.1
5	181.0	R41	6.4	15.7	3/4X3.50	3/4X4.50	266.7	8	1	28.4	28.4	139.7	177.8
6	211.1	R45	12.7	22.4	1X4.00	1X4.50	292.1	12	1	28.4	28.4	177.8	190.5
8	269.9	R49	12.7	22.4	1X4.00	1X4.75	349.3	12	1 1/8	31.8	31.8	196.9	209.6
10	323.9	R53	12.7	22.4	1X4.00	1X5.00	431.8	16	1 1/4	35.1	35.1	222.3	235.0
12	381.0	R57	12.7	22.4	1X4.50	1X5.00	489.0	20	1 1/4	35.1	35.1	228.6	241.3
14	419.1	R61	12.7	22.4	1X5.00	1X5.50	527.1	20	1 3/8	38.1	38.1	241.3	254.0
16	469.9	R65	12.7	22.4	1X5.00	1X5.50	603.3	20	1 1/2	41.1	41.1	260.4	273.1
18	533.4	R69	12.7	22.4	1X5.00	1X5.75	654.1	20	1 5/8	44.5	44.5	297.4	292.1
20	584.2	R73	12.7	22.4	1X6.00	1X6.25	723.9	24	1 5/8	44.5	44.5	298.5	317.5
24	692.2	R77	12.7	22.4	1X6.00	1X7.00	838.2	24	1 7/8	50.8	50.8	336.6	342.9

NOTE :

- Unless otherwise specified, raised face unions are furnished with alloy bolt studs per ASTM A193 Grade B7 with American Standard heavy series hex nuts ASTM A194 Class 2H.
- On ring joint flanges having a groove depth 0.375" (9.5mm) and less, the distance from the center line of the tap hole to the flange face is 0.750" (19.1mm). When the depth of groove is 0.438" (11.1mm) or greater, changes in drill size or method of drilling are necessary.

**CLASS 900 / 1500 ORIFICE FLANGES**

WELDING NECK  
(RAISED FACE)

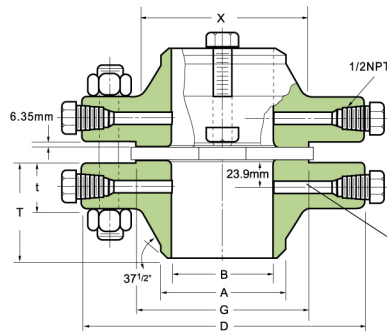

1/4" Drill for Sizes 2 1/2" and Under  
3/8" Drill for Sizes 3"  
1/2" Drill for Sizes 4" and Over

**ANSI B 16.36 Forged Flanges**

Unit : mm

Nominal Pipe Size	Outside Diam. of Flange D	THICKNESS OF FLANGE (t)		Diam. of Hub at Base X	Diam. of Raised Base G	Diam. of Hub of Bevel A	LENGTH THRU HUB (T)				BORE (B)	
		Raised Face	Ring Joint				Welding Neck		Slip-on & Threaded		Welding Neck	Slip-on
							Raised Face	Ring Joint	Raised Face	Ring Joint		
<b>CLASS 900</b>												
3	241	38.1	38.1	127.0	127.0	88.9	101.6	101.6	53.8	53.8	To be specified by purchaser	90.7
4	292	44.5	44.5	158.8	157.2	114.3	114.3	114.3	69.9	69.9		116.1
5	349	50.8	50.8	190.5	185.7	141.2	127.0	127.0	79.2	79.2		143.8
6	381	55.6	55.6	235.0	215.9	168.4	139.7	139.7	85.9	85.9		170.7
8	470	63.5	63.5	298.5	269.7	219.2	162.1	162.1	101.6	101.6		221.5
10	546	69.9	69.9	368.3	323.9	273.1	184.2	184.2	108.0	108.0		276.4
12	610	79.2	79.2	419.1	381.0	323.9	200.2	200.2	117.3	117.3		327.2
14	641	85.9	-	450.9	412.8	355.6	212.9	-	-	-		-
16	705	88.9	-	508.0	469.9	406.4	215.9	-	-	-		-
18	787	101.6	-	565.2	533.4	457.2	228.6	-	-	-		-
20	857	108.0	-	622.3	584.2	508.0	247.7	-	-	-	-	
24	1041	139.7	-	749.3	692.2	609.6	292.1	-	-	-	-	
<b>CLASS 1500</b>												
1	149	38.1	38.1	52.3	50.8	33.5	82.6	82.6	47.8	44.5	To be specified by purchaser	34.5
1 1/4	158	35.1	35.1	63.5	63.5	42.2	73.2	73.2	47.8	44.5		43.2
1 1/2	178	38.1	38.1	69.9	73.2	48.3	88.9	88.9	47.8	44.5		49.5
2	216	38.1	38.1	104.6	91.9	60.5	101.6	101.6	57.2	57.2		62.0
2 1/2	244	41.1	41.1	124.0	104.6	73.2	104.6	104.6	63.5	63.5		74.7
3	267	47.8	47.8	133.4	127.0	88.9	117.3	117.3	73.2	73.2		90.7
4	311	53.8	53.8	162.1	157.2	114.3	124.0	124.0	90.4	90.4		116.1
5	375	73.2	73.2	196.9	185.7	141.2	155.4	104.6	104.6	104.6		143.8
6	394	82.6	82.6	228.6	215.9	168.4	171.5	171.5	119.1	119.1		170.7
8	483	91.9	91.9	292.1	269.7	219.2	212.9	212.9	142.7	142.7		221.5
10	584	108.0	108.0	368.3	323.9	273.1	254.0	254.0	158.8	158.5	276.4	
12	673	124.0	124.0	450.9	381.0	323.9	282.4	282.4	180.8	180.8	327.2	
14	749	133.4	-	495.3	412.8	355.6	298.5	-	-	-	-	
16	826	146.1	-	552.5	469.9	406.4	311.2	-	-	-	-	
18	914	162.1	-	596.9	533.4	457.2	327.2	-	-	-	-	
20	984	177.8	-	641.4	584.2	508.0	355.6	-	-	-	-	
24	1168	203.2	-	762.0	692.2	609.6	406.4	-	-	-	-	

**NOTE :**

1. For the inside diameter of pipes (corresponding to 'Bore' (B) of Welding Neck Flanges), refer to page 46,47
2. Class 900 Flanges of sizes 1" (25.4mm) through 2 1/2" are the same as for Class 1500.
3. Class 900 and 1500 is not included in "thickness' (t) and 'Length through Hub' (t).
4. Each union includes two carbon steel jack screw bolts with hex nuts.

WELDING NECK  
(RING-TYPE JOINT)

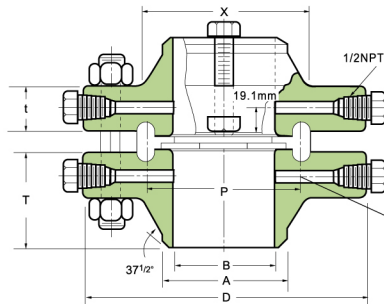

1/4" Drill for Sizes 2 1/2" and Under  
3/8" Drill for Sizes 3"  
1/2" Drill for Sizes 4" and Over

Unit : mm

Nominal Pipe Size	Pitch Diam. of Ring and Groove  P	Ring Number	DEPTH OF JACK SCREW SLOT		JACK SCREW SIZE		DRILLING TEMPLATE					
			Raised Face	Ring Joint	Raised Face (inch)	Ring Joint (inch)	Diam. of Bolt Circle	Number of Bolts	Diam. of Stud Bolts (inch)	Diam. of Bolts Holes	Length of Stud Bolts	
											Raised Face	Ring Joint
<b>CLASS 900</b>												
3	123.8	R31	9.7	15.7	3/4X3.50	3/4X4.00	190.5	8	7/8	25.4	152.4	165.1
4	149.2	R37	9.7	15.7	3/4X3.50	3/4X4.50	235.0	8	1 1/8	31.8	177.8	190.5
5	181.0	R41	9.7	15.7	3/4X3.50	3/4X4.50	279.4	8	1 1/4	35.1	190.5	203.2
6	211.1	R45	15.7	22.4	1X4.50	1X4.75	317.5	12	1 1/8	31.8	196.9	209.6
8	269.9	R49	15.7	22.4	1X4.50	1X5.00	393.7	12	1 3/8	38.1	228.6	241.3
10	323.9	R53	15.7	22.4	1X4.50	1X5.25	469.9	16	1 3/8	38.1	241.3	254.0
12	381.0	R57	15.7	22.4	1X4.50	1X5.50	533.4	20	1 3/8	38.1	260.4	273.1
14	-	-	-	-	-	-	558.8	20	1 1/2	41.1	279.4	-
16	-	-	-	-	-	-	616.0	20	1 5/8	44.5	292.1	-
18	-	-	-	-	-	-	685.8	20	1 7/8	50.8	330.2	-
20	-	-	-	-	-	-	749.3	20	2	53.8	355.6	-
24	-	-	-	-	-	-	901.7	20	2 1/2	66.5	444.5	-
<b>CLASS 1500</b>												
1	50.8	R16	6.4	12.7	5/8X3.00	5/8X3.50	101.6	4	7/8	25.4	152.4	158.8
1 1/4	60.3	R18	6.4	12.7	5/8X3.00	5/8X3.50	111.3	4	7/8	25.4	139.7	146.1
1 1/2	68.3	R20	6.4	12.7	5/8X3.00	5/8X3.50	124.0	4	1	28.4	158.8	165.1
2	95.3	R24	6.4	12.7	5/8X3.00	5/8X4.00	165.1	8	7/8	25.4	152.4	165.1
2 1/2	108.0	R27	6.4	12.7	5/8X3.00	5/8X4.00	190.5	8	1	28.4	165.1	177.8
3	136.5	R35	9.7	15.7	5/8X3.50	3/4X4.50	203.2	8	1 1/8	31.8	184.2	196.9
4	161.9	R39	9.7	15.7	5/8X3.50	3/4X4.50	241.3	8	1 1/4	35.1	203.2	215.9
5	193.7	R44	9.7	15.7	5/8X3.50	3/4X4.50	292.1	8	1 1/2	41.1	247.7	260.4
6	211.1	R46	15.8	22.4	1X6.00	1X6.50	317.5	12	1 3/8	38.1	266.7	279.4
8	269.9	R50	15.7	22.4	1X6.50	1X6.50	393.7	12	1 5/8	44.5	298.5	317.5
10	323.9	R54	15.7	22.4	1X6.50	1X7.00	482.6	12	1 7/8	50.8	342.9	362.0
12	381.0	R58	15.7	22.4	1X6.50	1X8.00	571.5	16	2	53.8	381.0	406.4
14	-	-	-	-	-	-	635.0	16	2 1/4	60.5	412.8	-
16	-	-	-	-	-	-	704.9	16	2 1/2	66.5	450.9	-
18	-	-	-	-	-	-	774.7	16	2 3/4	73.2	501.7	-
20	-	-	-	-	-	-	831.9	16	3	79.2	546.1	-
24	-	-	-	-	-	-	990.6	16	3 1/2	91.9	622.3	-

NOTE :

- Unless otherwise specified, raised face unions are furnished with alloy bolt studs per ASTM A193 Grade B7 with American Standard heavy series hex nuts ASTM A194 Class 2H.
- On ring joint flanges having a groove depth 0.375" (9.5mm) and less, the distance from the center line of the tap hole to the flange face is 0.750" (19.1mm). When the depth of groove is 0.438" (11.1mm) or greater, changes in drill size or method of drilling are necessary.
- Bolt lengths for raised face flanges include allowance for orifice and gasket thickness of 0.25" (6.4mm) for sizes 3-12 and 0.38" (9.7mm) for sizes 14-24. Bolt lengths for ring type joint flanges include allowance of 0.62" (15.7mm) for sizes 3-10, 0.75" (19.1mm) for sizes 12-18 and 0.88" (22.4mm) for size 20.

# CLASS 2500 ORIFICE FLANGES

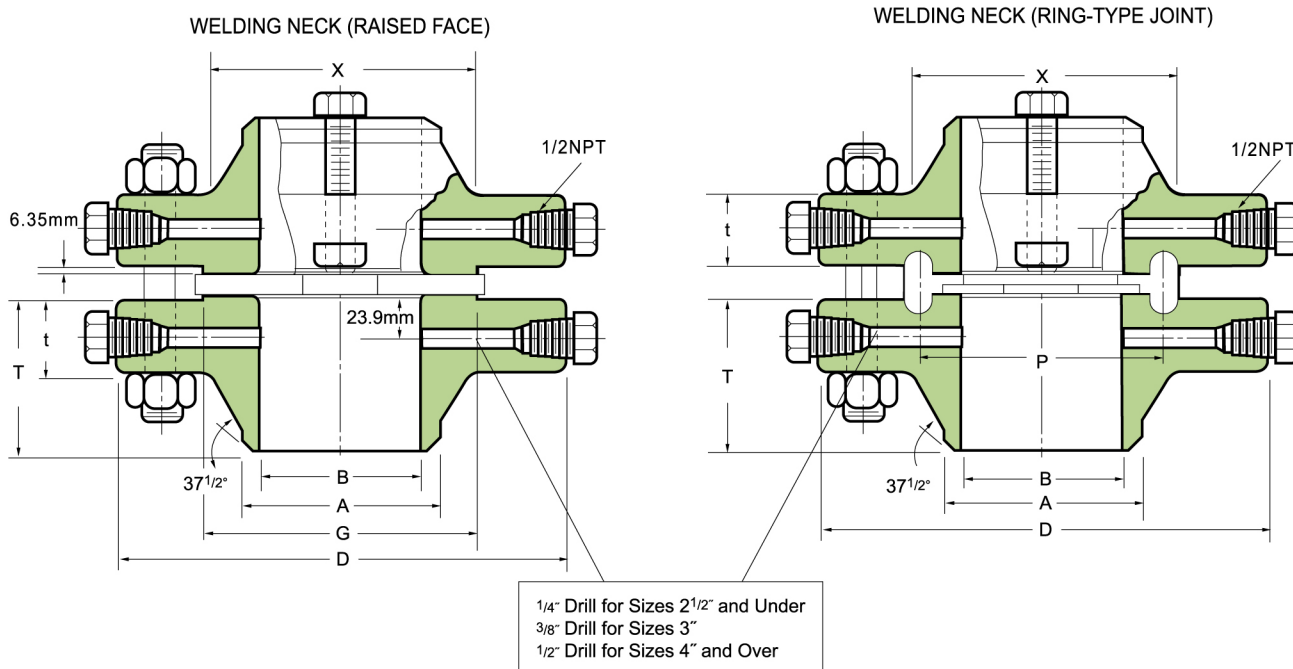

## ANSI B 16.36 Forged Flanges

Unit : mm

Nominal Pipe Size	O.D. of Flange Face	O.D. of Raised Flange	THK'S of Hub Min	Length Thru	Diam. of Hub	Diam. of Hub at Bevel	Bore	Ring Type Joing		DRILLING TEMPLATE				LENGTH OF STUD BOLTS	
								Pitch Diam.	Ring Number	Diam. Bolt Circle	Number of Holes	Diam. of Holes	Diam. of Bolts (inch)	Raised Face	Ring Joint
	D	G	t	T	X	A	B	P							
1	159	50.8	38.1	91.9	57.2	33.5	See Note 1. To be specified by purchaser	60.3	R18	108.0	4	25.4	7/8	152.4	158.8
1 1/2	203	73.2	44.5	111.3	79.2	48.3		82.6	R23	146.1	4	31.8	1 1/8	177.8	190.5
2	235	91.9	50.8	127.0	95.3	60.5		101.6	R26	171.5	8	28.4	1	184.2	196.9
2 1/2	267	104.6	57.2	142.7	114.3	73.2		111.1	R28	196.9	8	31.8	1 1/8	203.2	215.9
3	305	127.0	66.5	168.1	133.4	88.9		127.0	R32	228.6	8	35.1	1 1/4	228.6	241.3
4	356	157.2	76.2	190.5	165.1	114.3		-	-	273.1	8	41.1	1 1/2	260.4	-
6	483	215.9	108.0	273.1	235.0	168.4		-	-	368.3	8	53.8	2	349.3	-
8	552	269.7	127.0	317.5	304.8	219.2		-	-	438.2	12	53.8	2	387.4	-
10	673	323.9	165.1	419.1	374.7	273.1		-	-	539.8	12	66.5	2 1/2	489.0	-
12	762	381.0	184.2	463.6	441.5	323.9		-	-	619.3	12	73.2	2 3/4	539.8	-

**NOTE :**

- For the inside diameter of pipes (corresponding to 'Bore' (B) of Welding Neck Flanges), refer to page 46,47
- Class 2500 Flanges will be furnished with 0.25" (6.4mm) raised face, which is included in 'Thickness' (t) and 'Length through Hub' (T)
- Each union includes two carbon steel jack screw bolts with hex nuts.
- Unless otherwise specified, raised face unions are furnished with alloy bolt studs per ASTM A193 Grade B7 with American Standard heavy series hex nuts ASTM A194 Class 2H.
- On ring joint flanges having a groove depth 0.375" (9.5mm) and less, the distance from the center line of the tap hole to the flange face is 0.750" (19.1mm). When the depth of groove is 0.438" (11.1mm) or greater, changes in drill size or method of drilling are necessary.
- Class 2500 Slip-on flanges are not covered by ANSI B16.5.
- Bolt lengths for raised face flanges include allowance for orifice and gasket thickness of 0.25" (6.4mm) for sizes 1-12 and 0.38" (9.7mm) for sizes 14-24. Bolt lengths for ring type joint flanges include allowance of 0.62" (15.7mm) for sizes 1-6.





**PAP** PETRO ARTAN PART

# LONG WELDING NECK FLANGES

- Class 150 Flanges
- Class 300 Flanges
- Class 400 Flanges
- Class 600 Flanges
- Class 900 Flanges
- Class 1500 Flanges
- Class 2500 Flanges

## CLASS 150 FLANGES

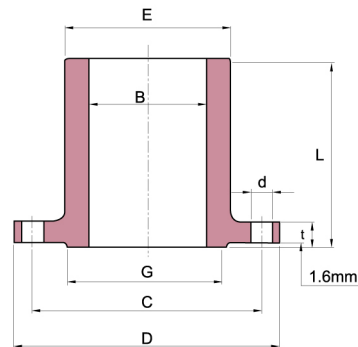

Unit : mm

Nominal Pipe Size	Outside Diam.	O.D of Raised Face	Hub Diameter of Bevel	Diameter of Bore	Thickness of Flange Min	Length Thru Hub	DRILLING		
							Diameter of Bolt Circle	Number of Holes	Diameter of Holes
	D	G	E	B	t	L	C		d
1/2	89	34.9	30.2	12.7	11.2	228.6	60.5	4	15.7
3/4	99	42.9	38.1	19.1	12.7	228.6	69.9	4	15.7
1	108	50.8	50.8	25.4	14.2	228.6	79.2	4	15.7
1 1/4	117	63.5	60.5	31.8	15.7	228.6	88.9	4	15.7
1 1/2	127	73.0	66.5	38.1	17.5	228.6	98.6	4	15.7
2	152	91.9	82.6	50.8	19.1	228.6	120.7	4	19.1
2 1/2	178	104.6	95.3	63.5	22.4	228.6	139.7	4	19.1
3	191	127.0	108.0	76.2	23.9	228.6	152.4	4	19.1
3 1/2	216	139.7	124.0	88.9	23.9	228.6	177.8	8	19.1
4	229	157.2	139.7	101.6	23.9	304.8	190.5	8	19.1
5	254	185.7	165.1	127.0	23.9	304.8	215.9	8	22.4
6	279	215.9	196.9	152.4	25.4	304.8	241.3	8	22.4
8	343	269.7	247.7	203.2	28.4	304.8	298.5	8	22.4
10	406	323.9	304.8	254.0	30.2	304.8	362.0	12	25.4
12	483	381.0	365.3	304.8	31.8	304.8	431.8	12	25.4
14	533	412.8	406.4	355.6	35.1	304.8	476.3	12	28.4
16	597	469.9	457.2	406.4	36.6	304.8	539.8	16	28.4
18	635	533.4	508.0	457.2	39.6	304.8	577.9	16	31.8
20	699	584.2	558.8	508.0	42.9	304.8	635.0	20	31.8
24	813	692.2	666.8	609.6	47.8	304.8	749.3	20	35.1

## CLASS 300 FLANGES

Unit : mm

Nominal Pipe Size	Outside Diam.	O.D of Raised Face	Hub Diameter of Bevel	Diameter of Bore	Thickness of Flange Min	Length Thru Hub	DRILLING		
							Diameter of Bolt Circle	Number of Holes	Diameter of Holes
	D	G	E	B	t	L	C		d
1/2	95	35.1	38.1	12.7	14.2	228.6	66.5	4	15.7
3/4	117	42.9	47.8	19.1	15.7	228.6	82.6	4	19.1
1	124	50.8	53.8	25.4	17.5	228.6	88.9	4	19.1
1 1/4	133	63.5	63.5	31.8	19.1	228.6	98.6	4	19.1
1 1/2	155	73.2	69.9	38.1	20.6	228.6	114.3	4	22.4
2	165	91.9	84.1	50.8	22.4	228.6	127.0	8	19.1
2 1/2	191	104.6	100.1	63.5	25.4	228.6	149.4	8	22.4
3	210	127.0	117.3	76.2	28.4	228.6	168.1	8	22.4
3 1/2	229	139.7	133.4	88.9	30.2	228.6	184.2	8	22.4
4	254	157.2	146.1	101.6	31.8	304.8	200.2	8	22.4
5	279	185.7	177.8	127.0	35.1	304.8	235.0	8	22.4
6	318	215.9	206.2	152.4	36.6	304.8	269.7	12	22.4
8	381	269.7	260.4	203.2	41.1	304.8	330.2	12	25.4
10	445	323.9	320.5	254.0	47.8	304.8	387.4	16	28.4
12	521	381.0	374.7	304.8	50.8	304.8	450.9	16	31.8
14	584	412.8	425.5	355.6	53.8	304.8	514.4	20	31.8
16	648	469.9	482.6	406.4	57.2	304.8	571.5	20	35.1
18	711	533.4	533.4	457.2	60.5	304.8	628.7	24	35.1
20	775	584.2	587.2	508.0	63.5	304.8	685.8	24	35.1
24	914	692.2	701.5	609.6	69.9	304.8	812.8	24	41.1

NOTE : 1. Bore (B) is the same as nominal pipe size.  
 2. Welding necks longer than listed are available in all sizes on special order.

**CLASS 400 FLANGES**

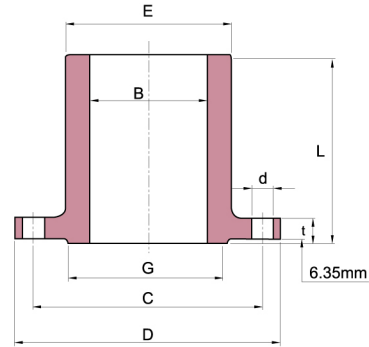

Unit : mm

Nominal Pipe Size	Outside Diam. D	O.D of Raised Face G	Hub Diameter of Bevel E	Diameter of Bore B	Thickness of Flange Min t	Length Thru Hub L	DRILLING		
							Diameter of Bolt Circle C	Number of Holes	Diameter of Holes d
1/2									
3/4									
1									
1 1/4									
1 1/2									
2									
2 1/2									
3									
3 1/2									
4	254	157.2	146.1	101.6	35.1	304.8	200.2	8	25.4
5	279	185.7	177.8	127.0	38.1	304.8	235.0	8	25.4
6	318	215.9	206.2	152.4	41.1	304.8	269.7	12	25.4
8	381	269.7	260.4	203.2	47.8	304.8	330.2	12	28.4
10	445	323.9	320.5	254.0	53.8	304.8	387.4	16	31.8
12	521	381.0	374.7	304.8	57.2	304.8	450.9	16	35.1
14	584	412.8	425.5	355.6	60.5	304.8	514.4	20	35.1
16	648	469.9	482.6	406.4	63.5	304.8	571.5	20	38.1
18	711	533.4	533.4	457.2	66.5	304.8	628.7	24	38.1
20	775	584.2	587.2	508.0	69.9	304.8	685.8	24	41.1
24	914	692.2	701.5	609.6	76.2	304.8	812.8	24	47.8

Use Class 600 dimensions in these sizes.

**CLASS 600 FLANGES**

Unit : mm

Nominal Pipe Size	Outside Diam. D	O.D of Raised Face G	Hub Diameter of Bevel E	Diameter of Bore B	Thickness of Flange Min t	Length Thru Hub L	DRILLING		
							Diameter of Bolt Circle C	Number of Holes	Diameter of Holes d
1	124	50.8	53.8	25.4	17.5	228.6	88.9	4	19.1
1 1/4	133	63.5	63.5	31.8	20.6	228.6	98.6	4	19.1
1 1/2	155	73.2	69.9	38.1	22.4	228.6	114.3	4	22.4
2	165	91.9	84.1	50.8	25.4	228.6	127.0	8	19.1
2 1/2	191	104.6	100.1	63.5	28.4	228.6	149.4	8	22.4
3	210	127.0	117.3	76.2	31.8	228.6	168.1	8	22.4
3 1/2	229	139.7	133.4	88.9	35.1	228.6	184.2	8	25.4
4	273	157.2	152.4	101.6	38.1	304.8	215.9	8	25.4
5	330	185.7	190.5	127.0	44.5	304.8	266.7	8	28.4
6	356	215.9	222.3	152.4	47.8	304.8	292.1	12	28.4
8	419	269.7	273.1	203.2	55.6	304.8	349.3	12	31.8
10	508	323.9	342.9	254.0	63.5	304.8	431.8	16	35.1
12	559	381.0	400.1	304.8	66.5	304.8	489.0	16	35.1
14	603	412.8	431.8	355.6	69.9	304.8	527.1	20	38.1
16	686	469.9	495.3	406.4	76.2	304.8	603.3	20	41.1
18	743	533.4	546.1	457.2	82.6	304.8	654.1	20	44.5
20	813	584.2	609.6	508.0	88.9	304.8	723.9	24	44.5
24	940	692.2	717.6	609.6	101.6	304.8	838.2	24	50.8

NOTE : 1. Bore (B) is the same as nominal pipe size.  
2. Welding necks longer than listed are available in all sizes on special order.

**CLASS 900 FLANGES**

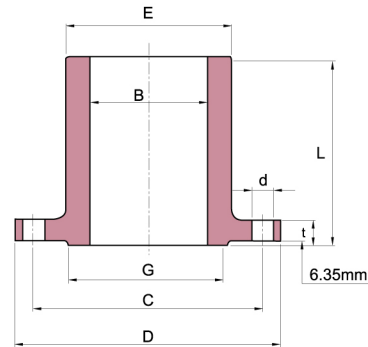

Unit : mm

Nominal Pipe Size	Outside Diam.	O.D of Raised Face	Hub Diameter of Bevel	Diameter of Bore	Thickness of Flange Min	Length Thru Hub	DRILLING		
							Diameter of Bolt Circle	Number of Holes	Diameter of Holes
	D	G	E	B	t	L	C		d
1									
1 1/4									
1 1/2									
2									
2 1/2									
3	241	127.0	127.0	76.2	38.1	304.8	190.5	8	22.4
4	292	157.2	158.8	101.6	44.5	304.8	235.0	8	31.8
5	349	185.7	190.5	127.0	50.8	304.8	279.4	8	35.1
6	381	215.9	235.0	152.4	55.6	304.8	317.5	12	31.8
8	470	269.7	298.5	203.2	63.5	304.8	393.7	12	38.1
10	546	323.9	368.3	254.0	69.9	406.4	469.9	16	38.1
12	610	381.0	419.1	304.8	79.2	406.4	533.4	20	38.1
14	641	412.8	450.9	355.6	85.9	To be specified by Purchaser.	558.8	20	41.1
16	705	469.9	508.0	406.4	88.9		616.0	20	44.5
18	787	533.4	565.2	457.2	101.6		685.8	20	50.8
20	857	584.2	622.3	508.0	108.0		749.3	20	53.8
24	1041	692.2	749.3	609.6	139.7		901.7	20	66.5

Use Class 1500 dimensions in these sizes.

**CLASS 1500 FLANGES**

Unit : mm

Nominal Pipe Size	Outside Diam.	O.D of Raised Face	Hub Diameter of Bevel	Diameter of Bore	Thickness of Flange Min	Length Thru Hub	DRILLING		
							Diameter of Bolt Circle	Number of Holes	Diameter of Holes
	D	G	E	B	t	L	C		d
1	149	50.8	52.4	25.4	28.4	228.6	101.6	4	25.4
1 1/4	159	63.5	63.5	31.8	28.4	228.6	111.3	4	25.4
1 1/2	178	73.2	69.9	38.1	31.8	228.6	124.0	4	28.4
2	216	91.9	104.6	50.8	38.1	228.6	165.1	8	25.4
2 1/2	244	104.6	124.0	63.5	41.1	304.8	190.5	8	28.4
3	267	127.0	133.4	76.2	47.8	304.8	203.2	8	31.8
4	311	157.2	162.1	101.6	53.8	304.8	241.3	8	35.1
5	375	185.7	196.9	127.0	73.2	304.8	292.1	8	41.1
6	394	215.9	228.6	152.4	82.6	304.8	317.5	12	38.1
8	483	269.7	292.1	203.2	91.9	304.8	393.7	12	44.5
10	584	323.9	368.3	254.0	108.0	406.4	482.6	12	50.8
12	673	381.0	450.9	304.8	124.0	406.4	571.5	16	53.8
14	749	412.8	495.3	355.6	133.4	To be specified by Purchaser.	635.0	16	60.5
16	826	469.9	552.5	406.4	146.1		704.9	16	66.5
18	914	533.4	596.9	457.2	162.1		774.7	16	73.2
20	984	584.2	641.4	508.0	177.8		831.9	16	79.2
24	1168	692.2	762.0	609.6	203.2		990.6	16	91.9

NOTE : 1. Bore (B) is the same as nominal pipe size.  
2. Welding necks longer than listed are available in all sizes on special order.



**CLASS 2500 FLANGES**

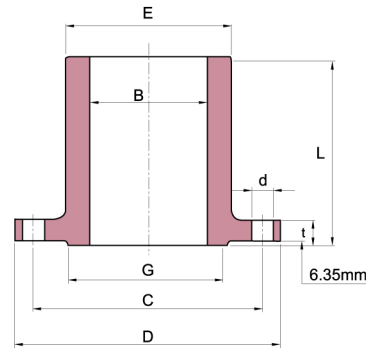

Unit : mm

Nominal Pipe Size	Outside Diam.	O.D of Raised Face	Hub Diameter of Bevel	Diameter of Bore	Thickness of Flange Min	Length Thru Hub	DRILLING		
							Diameter of Bolt Circle	Number of Holes	Diameter of Holes
	D	G	E	B	t	L	C		d
1	159	50.8	57.2	25.4	35.1	228.6	108.0	4	25.4
1 1/4	184	63.5	73.2	31.8	38.1	228.6	130.0	4	28.4
1 1/2	203	73.2	79.2	38.1	44.5	228.6	146.1	4	31.8
2	235	91.9	95.3	50.8	50.8	228.6	171.5	8	28.4
2 1/2	267	104.6	114.3	63.5	57.2	304.8	196.9	8	31.8
3	305	127.0	133.4	76.2	66.5	304.8	228.6	8	35.1
4	356	157.2	165.1	101.6	76.2	304.8	273.1	8	41.1
5	419	185.7	203.2	127.0	91.9	304.8	323.9	8	47.8
6	483	215.9	235.0	152.4	108.0	304.8	368.3	8	53.8
8	552	269.7	304.8	203.2	127.0	304.8	438.2	12	53.8
10	673	323.9	374.7	254.0	165.1	406.4	539.8	12	66.5
12	762	381.0	441.5	304.8	184.2	406.4	619.3	16	73.2

**GUIDE TO MATERIAL LAYOUT & SPECIFICATIONS**

Pipe	Weld Fittings	Screwed & Scket Fittings	Flanges	Valves
A-53	A-234 WPB	A-105, A-181 Gr. 60 or 70	A-105, A-181 Gr. 60 or 70	A-105 A-216 WCB
A-106B	A-234 WPB	A-105, Gr. 60 or 70	A-105, Gr. 60 or 70	A-105 A-216 WCB
A-312 T304	A-403 WP-304	A-182 F-304	A-182 F-304	A-182 F-304 CMO
A-312 T316	A-403 WP-316	A-182 F-316	A-182 F-316	A-182 F-316 CM 8MO
A-333 Gr. 1or6	A-420 WPL 1&6	A-350 LF-1	A-350 LF-1	A-350 LF-1 A-352 LCB
A-333 Gr. 3	A-420 WPL-3	A-350 LF-3	A-350 LF-3	A-350 LF-3 A-352 LC3
A-335 P-1	A-234 WP-1	A-182 F-1	A-182 F-1	A-217 WC-6
A-335 P-11	A-234 WP-11	A-182 F-11	A-182 F-11	A-182 F-11 A-217 WC-6
A-335 P-12	A-234 WP-12	A-182 F-12	A-182 F-12	A-217 WC-6
A-335 P-22	A-234 WP-22	A-182 F-22	A-182 F-22	A-182 F-22 A-217 WC-9
A-335 P-5	A-234 WP-5	A-182 F-5	A-182 F-5	A-182 F-5 A-216 WC-5
A-335 P-7	A-234 WP-7	A-182 F-7	A-182 F-7	A-182 F-7 A-217 WC-12
A-335 P-9	A-234 WP-9	A-182 F-9	A-182 F-9	A-182 F-9 A-217 WC-12

NOTE : 1. Bore (B) is the same as nominal pipe size.  
2. Welding necks longer than listed are available in all sizes on special order.

## REDUCING FLANGES

### Threaded and Slip-on Types

#### ■ HUB

For hub diameter (X) and height of hub above the back of the flange (N) refer to the list of standard flange specification of the same type and pressure and use the dimensions of a flange one nominal pipe size smaller than the nominal pipe size from which the reduction is being made.

#### ■ FLANGE O.D., DRILLING TEMPLATE AND THICKNESS

Outside diameter, drilling template and flange thickness Q (See note on FACINGS) agree with the dimensions of a standard flange of the nominal pipe size from which the reduction is being made.

#### ■ FACING

Facing dimensions also agree with the dimensions of a standard flange of the nominal pipe size from which the reduction is being made.

150 lb. and 300 lb. forged steel Threaded, Slip-On, Welding Neck and Blind flanges are furnished with American Standard 1/16" raised face which is included in flange thickness. Q. 400 lb., 600 lb., 900 lb., 1500 lb., 1500 lb. and 2500 lb. flange are supplied with American Standard 1/4" raised face which is not included in flange thickness (Q)

#### ■ BORE OR TAPPING

The bore or tapping is machined to accept a pipe of the nominal pipe size to which the reduction is being made. For reduction to size smaller than shown, BLIND FLANGE are tapped or bored to specified nominal pipe size.

#### EXAMPLE :

A 300 lb. threaded flange used in reducing from a 6" (152.4mm) to 3" (76.2mm) nominal pipe size should be specified as a 3" (76.2mm) x 12 1/2" - 300 lb. Threaded Reducing Flange. It would have the following dimensional characteristics :

Diameter of Hub (X) - 7" (177.8mm).

Height of Hub (N) - 5/8".

Hub dimensions are those of a 5" (127.0mm), 300lb, Standard flange.

Outside Diameter - 12 1/2"

Thickness (Q) - 1 7/16"

Raised face - 1/16".

O.D., Flange Thickness Q., Raised Face and Drilling Template are those of a 6" (152.4mm), 300lb. Standard Flange.

Tapping - 3" (76.2mm) I.P.S.

Flange is tapped to the nominal pipe size to which reduction is being made.

#### WELDING NECK TYPES

On Reducing Welding Neck Flanges. which are made only on special order, the hub dimensions agree with the hub dimensions of standard flanges of the size to which reduction is being made. Other flange dimensions, including the drilling template, agree with the standard dimensions of the size from which the reduction is being made.

# REDUCING FLANGES

Threaded-Slip-on-Welding neck

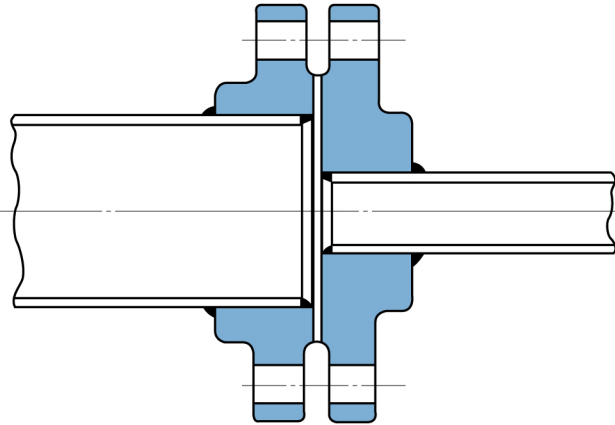

In ordering Reducing Flanges : specify (1) nominal pipe size of the tapping or bore to which the reduction is being made.  
 (2) the outside diameter of the flange from which the reduction is being made and (3) pressure rating.

**EXAMPLE :**

A 300 lb. Reducing flange for reducing from a 6" (152.4mm) to a 3" (76.2mm) nominal pipe size should be designated as a 3" (76.2mm) x 12 1/2" - 300 lb. Reducing Flange. Whether Threaded, Slip-On, or Welding Neck type is desired must also be specified.

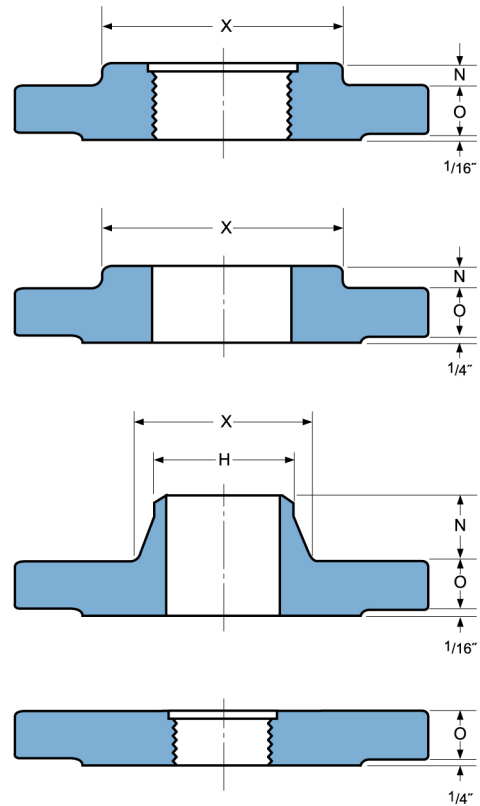

## ANSI B 16.5 Forged Flanges

Dimensions inches.

Nominal Flange	OUTSIDE DIAMETER OF FLANGE FROM WHICH REDUCTION IS BEING MADE							Smallest Size Bore or Tapping Requiring Hub Flange
	150 lb. Standard	300 lb. Standard	400 lb. Standard	600 lb. Standard	900 lb. Standard	1500 lb. Standard	2500 lb. Standard	
3/4	3 7/8	4 5/8	4 5/8	4 5/8	5 1/8	5 1/8	5 1/2	1/2
1	4 1/4	4 7/8	4 7/8	4 7/8	5 7/8	5 7/8	6 1/4	1/2
1 1/4	4 5/8	5 1/4	5 1/4	5 1/4	6 1/4	6 1/4	7 1/4	1/2
1 1/2	5	6 1/8	6 1/8	6 1/8	7	7	8	1/2
2	6	6 1/2	6 1/2	6 1/2	8 1/2	8 1/2	9 1/4	1
2 1/2	7	7 1/2	7 1/2	7 1/2	9 5/8	9 5/8	10 1/2	1 1/4
3	7 1/2	8 1/4	8 1/4	8 1/4	9 1/2	10 1/2	12	1 1/4
3 1/2	8 1/2	9	9	9	-	-	-	1 1/2
4	9	10	10	10 3/4	11 1/2	12 1/4	14	1 1/2
5	10	11	11	13	13 3/4	14 3/4	16 1/2	1 1/2
6	11	12 1/2	12 1/2	14	15	15 1/2	19	2 1/2
8	13 1/2	15	15	16 1/2	18 1/2	19	21 3/4	3
10	16	17 1/2	17 1/2	20	21 1/2	23	26 1/2	3 1/2
12	19	20 1/2	20 1/2	22	24	26 1/2	30	3 1/2
14	21	23	23	23 3/4	25 1/4	-	-	3 1/2
16	23 1/2	25 1/2	25 1/2	27	27 3/4	-	-	4
18	25	28	28	29 1/4	31	-	-	4
20	27 1/2	30 1/2	30 1/2	32	33 3/4	-	-	4
24	32	36	36	37	41	-	-	4

NOTE :  
 For reductions to size smaller than shown, blind flange are tapped or bored for specified nominal pipe size.

# STANDARD FINISH

## Standard Finishes for Face of Flange(ANSI B16.5)

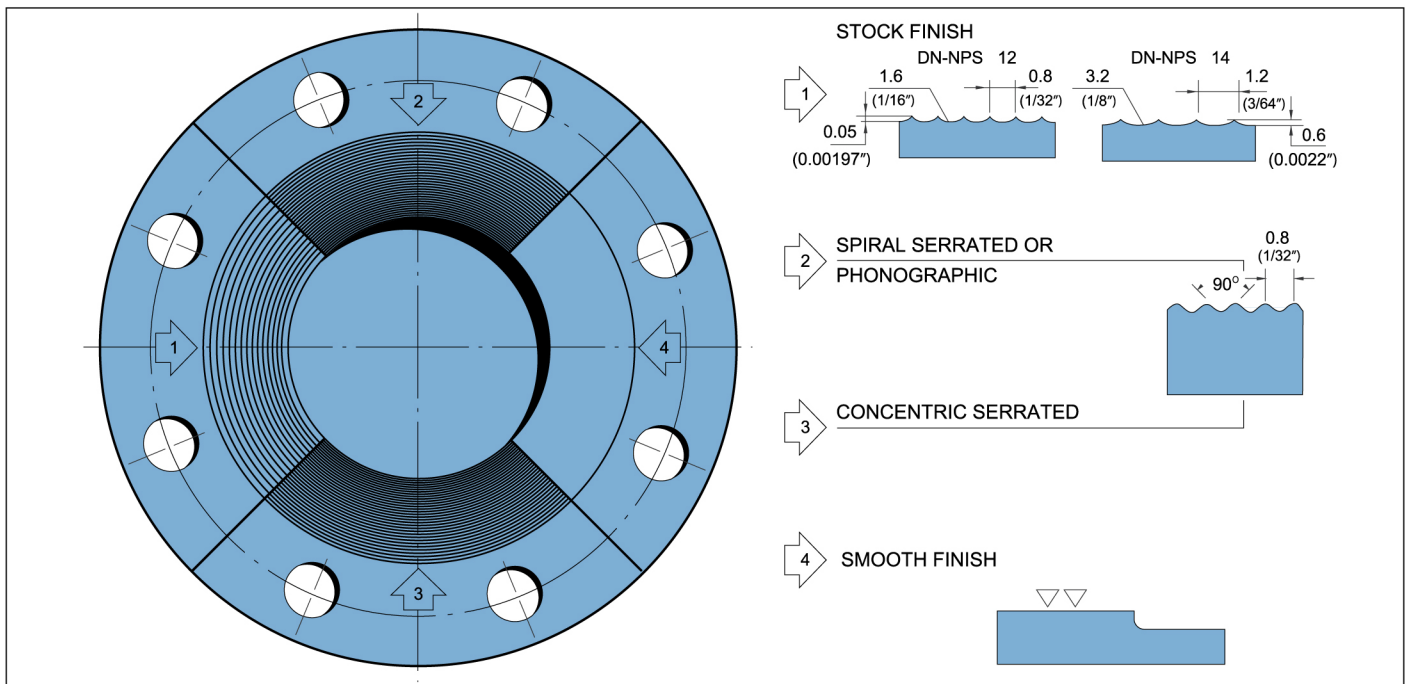

**STOCK FINISH :** The most widely used of any gasket finish, because, practically, is suitable for all ordinary service conditions. This is a continuous spiral groove. Flanges sizes 12” (304.8mm) and smaller, are produced with a 1/16” round nosed tool at a feed of 1/32” per revolution. For sizes 14” (355.6mm) and larger, the finish is made with 1/8” round-nosed tool at a feed of 3/64” per revolution.

**SPIRAL SERRATED OR PHONOGRAPHIC :** This finish is produced by using a 90° round nosed tool.

**CONCENTRIC SERRATED :** This finish is produced by using a 90° round nosed tool.

**SMOOTH FINISH :** The cutting tool employed shall have an approximate 0.06” radius. The resultant surface finish shall have a 125 μ inch to 250 μ inch (ANSI B 16.5 para 6, 4, 4)

■ **RAISED FACE, AND LARGE MALE AND FEMALE**

Either a serrated-concentric or serrated-spiral finish having from 45 to 55 grooves per inch is used. The cutting tool employed has an approximate 0.06 in, radius. The resultant surface finish shall have a 125 μ inch (3.2μm), to 250 μ inch (6.4μm) approximate roughness.

■ **TONGUE AND GROOVE, AND SMALL MALE AND FEMALE**

The gasket contact surface does not exceed 125 μ in (3.2μm) roughness.

■ **RING JOINT**

The inside wall surface of gasket groove does not exceed 63 μ in (1.6μm) roughness.

■ **BLIND**

Blind flanges need not be faced in the center if, when this center part is raised, its diameter is at least 1 in smaller than the inside diameter of fittings of the corresponding pressure class. When the center part is depressed, its diameter is not greater than the inside diameter of the corresponding pressure class fittings. Maching of the depressed center is not required.



# TOLERANCE

## ANSI B16.5 Forged Flanges

SOLID FANAGE

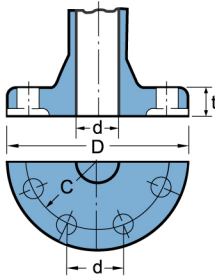

SLIP-ON FLANGE

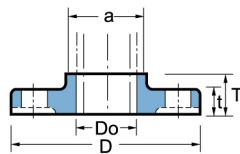

WELDING NECK FLANGE

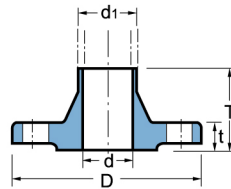

TYPE OF GASKET SURFACE

MALE & FEMALE TYPE

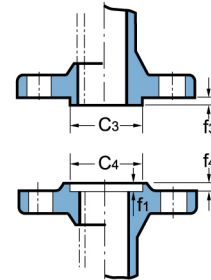

TONGUE & GROOVE TYPE

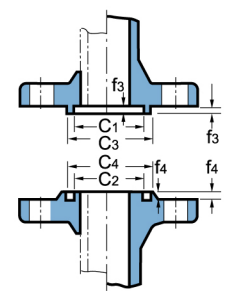

### THREADED, SOCKET-WELDING, SLIP-ON, LAP JOINT AND BLIND

Outside Diameter	When O.D. is 24" or less	$\pm 1/16'' (1.6\text{mm})^*$
	When O.D. is Over 24"	$\pm 1/8'' (3.2\text{mm})^*$
Inside Diameter	Threaded	Within limits on boring gauge
	Socket-Welding, Slip-on and Lap joint	10" & Smaller $+1/32'' (0.8\text{mm}), -0''$ 12" & Larger $+1/16'' (1.6\text{mm}), -0''$
Outside Diameter of Hub	5" and Smaller	$+3/32'' (2.4\text{mm})^*$ $-1/32'' (0.8\text{mm})$
	6" and Larger	$+5/32'' (4.0\text{mm})$ $-1/32'' (0.8\text{mm})$
Diameter of Contact Face	1/16" Raised Face	$+1/32'' (0.8\text{mm})$
	1/4" Raised Face Tongue & Groove Male, Female	$+1/64'' (0.4\text{mm})$
Diameter of Counterbore	Same as for Inside Diameter	
Drilling	Bolt Circle	$\pm 1/16'' (1.6\text{mm})$
	Bolt Hole Spacing	$\pm 1/32'' (0.8\text{mm})$
	Eccentricity of Bolt Circle with Respect to Facing	2 1/2" & Smaller $1/32'' (0.8\text{mm})$ Max. 3" & Larger $1/16'' (1.6\text{mm})$ Max.
	Eccentricity of Bolt Circle with Respect to Bore	$1/32'' (0.8\text{mm})$ Max.*
Thickness	18" and Smaller	$+1/8'' (3.2\text{mm}), -0''$
	20" and Larger	$+3/16'' (4.8\text{mm}), -0''$
Length Thru Hub	10" and Smaller	$\pm 1/16'' (1.6\text{mm})$
	12" and Larger	$\pm 1/8'' (3.2\text{mm})$

NOTE : \* This tolerance is not covered in ANSI B16.5, but maker's option

### WELDING NECK

Outside Diameter	When O.D. is 24" or less	$\pm 1/16'' (1.6\text{mm})^*$
	When O.D. is Over 24"	$\pm 1/8'' (3.2\text{mm})^*$
Inside Diameter	10" and Smaller	$\pm 1/32'' (0.8\text{mm})$
	12" thru 18"	$\pm 1/16'' (1.6\text{mm})$
	20" and Larger	$+1/8'' (3.2\text{mm})$ $-1/16'' (1.6\text{mm})$
Diameter of Contact Face	1/16" Raised Face	$\pm 1/32'' (0.8\text{mm})$
	1/4" Raised Face Tongue & Groove Male, Female	$+1/64'' (0.4\text{mm})$
Diameter of Hub at Base	When Hub Base is 24" or Smaller	$\pm 1/16'' (1.6\text{mm})$
	When Hub Base is Over 24"	$\pm 1/8'' (3.2\text{mm})$
Diameter of Hub at Point of Welding	5" and Smaller	$+3/32'' (2.4\text{mm})$ $-1/32'' (0.8\text{mm})$
	6" and Larger	$+5/32'' (4.0\text{mm})$ $-1/32'' (0.8\text{mm})$
Drilling	Bolt Circle	$\pm 1/16'' (1.6\text{mm})$
	Bolt Hole Spacing	$\pm 1/32'' (0.8\text{mm})$
	Eccentricity of Bolt Circle with Respect to Facing	2 1/2" & Smaller $1/32'' (0.8\text{mm})$ Max. 3" & Larger $1/16'' (1.6\text{mm})$ Max.
	Eccentricity of Bolt Circle with Respect to Bore	$1/32'' (0.8\text{mm})$ Max.*
Thickness	18" and Smaller	$+1/8'' (3.2\text{mm}), -0''$
	20" and Larger	$+3/16'' (4.8\text{mm}), -0''$
Length Thru Hub	4" and Smaller	$\pm 1/16'' (1.6\text{mm})$
	5" ~ 10"	$+1.6 \sim 3.0\text{mm}$
	12" and Larger	$+3.0 \sim 5.0\text{mm}$

NOTE : \* This tolerance is not covered in ANSI B16.5, but maker's option

# THREAD

## Thread and Standards for ANSI Flanges (ANSI B2.1)

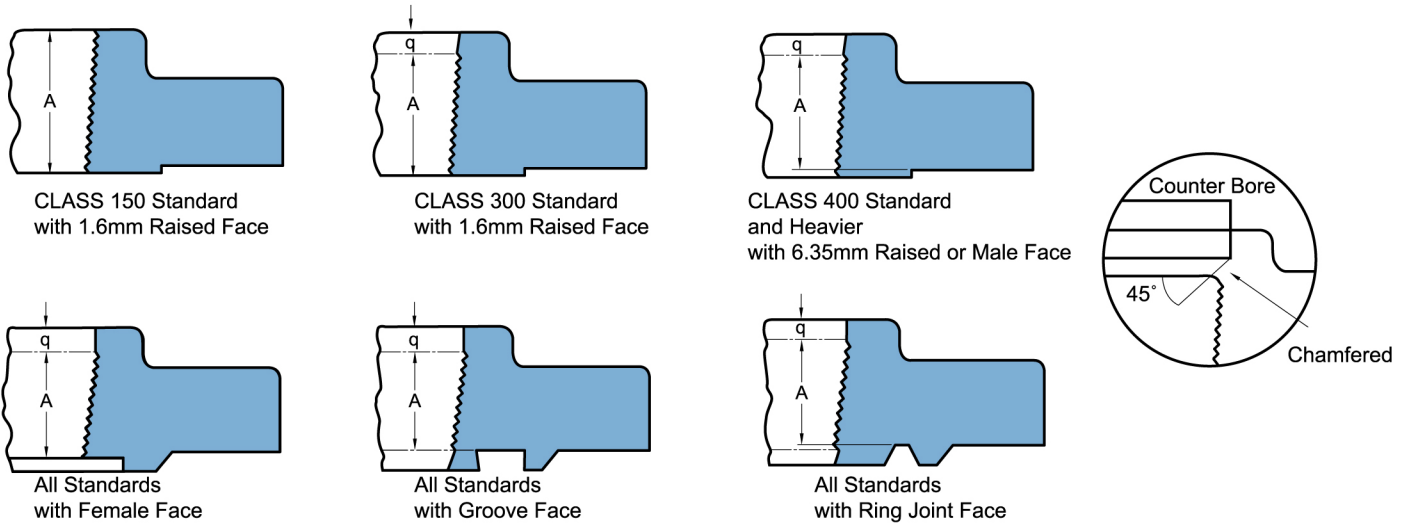

## ANSI B 16.5 Forged Flanges

Unit : mm

Nominal Pipe Size	A-THREAD LENGTHS						
	Class 150	Class 300	Class 400	Class 600	Class 900	Class 1500	Class 2500
1/2	15.9	15.9	15.9	15.9	22.2	22.2	28.6
3/4	15.9	15.9	15.9	15.9	25.4	25.4	31.8
1	17.5	17.5	17.5	17.5	28.6	28.6	34.9
1 1/4	20.7	20.7	20.7	20.7	30.2	30.2	38.1
1 1/2	22.2	22.2	22.2	22.2	31.8	31.8	44.5
2	25.4	28.6	28.6	28.6	38.1	38.1	50.8
2 1/2	28.6	31.8	31.8	31.8	47.6	47.6	57.2
3	30.1	31.8	34.9	34.9	41.3	50.8	63.5
3 1/2	31.8	36.5	39.7	39.7	-	-	-
4	33.4	36.5	36.5	41.3	47.6	57.2	69.9
5	36.5	42.9	42.9	47.6	54.0	63.5	76.2
6	39.7	46.1	46.1	50.8	57.2	69.9	82.6
8	44.5	50.8	50.8	60.3	63.5	76.2	95.3
10	49.2	55.6	55.6	65.1	71.5	84.2	108.0
12	55.6	60.3	60.3	69.9	76.2	92.1	120.7
14	57.2	63.5	63.5	73.0	82.6	-	-
16	63.5	68.3	68.3	77.8	85.7	-	-
18	68.3	69.9	69.9	79.4	88.9	-	-
20	69.9	73.0	73.0	82.6	92.1	-	-
24	82.6	82.6	82.6	92.1	101.6	-	-

**NOTE :**

1. Except flanges with Small Male / Female face (on pipe end), threaded flanges, have an American National Standard taper pipe thread conforming to ANSI B2.1
2. The thread is concentric with the axis of the flange and variations in alignment do not exceed 0.06"(1.6mm)in, per foot (05. percent).
3. Class 150 flanges are made without counterbore. The threads are chamfered approximately to the major diameter of the thread at the back of the flange at an angle of approximately 45 degrees with the axis of the thread. The chamfer is concentric with the thread and included in the measurement of the thread length.
4. Class 300 and higher pressure flanges are made with a counterbore at the back of the flange. The threads are chamfered to the diameter of the counterbore at an angle of approximately 45 degrees with the axis of the thread. The counterbore and chamfer are concentric with the thread.
5. The minimum length of effective thread in reducing flanges is at least equal to dimension Q of the corresponding class of threaded flange as shown in the above table. Threads do not necessarily extend to the face to the flange.

# WELDING ENDS

## ANSI B16.5 Forged Flanges

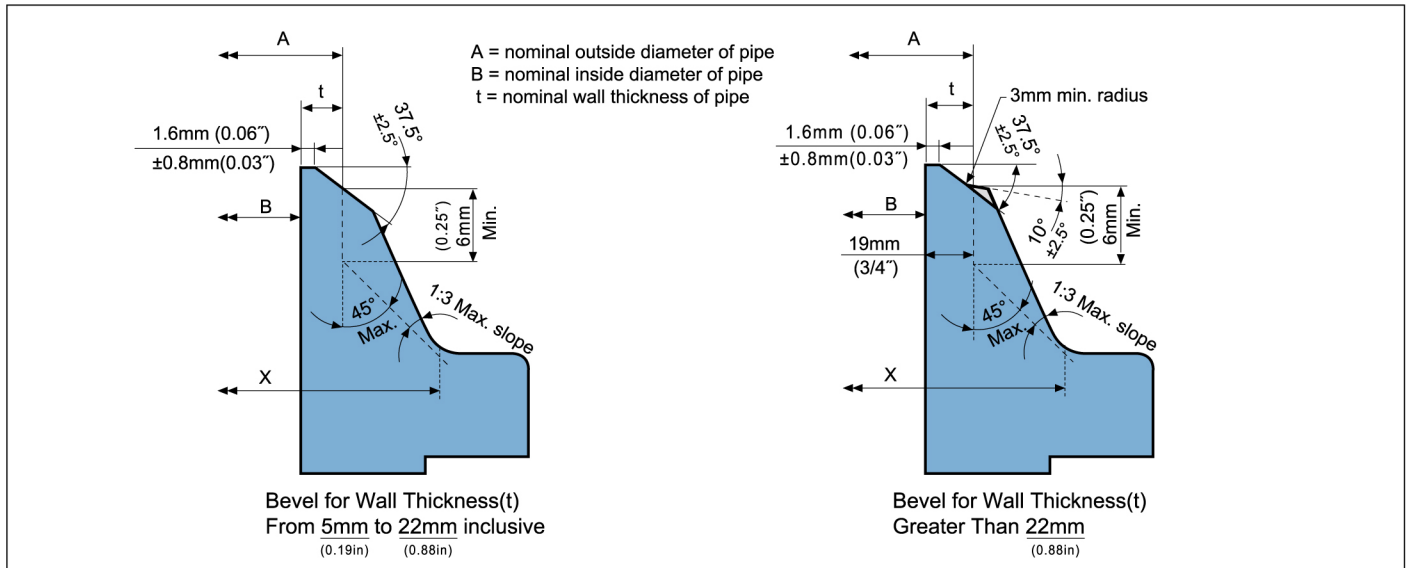

**Notes :**

When the thickness of the hub at the bevel is greater than that of the pipe to which the flange is joined and the additional thickness is provided on the outside diameter, a taper weld having a slope not exceeding 1 to 3 may be employed or, alternatively, the greater outside diameter may be tapered, at the same maximum slope or less, from a point on the welding bevel equal to the O.D. at the mating pipe. Similarly, when the greater thickness is provided on the inside of the flange, it shall be taper-bored from the welding end at a slope not exceeding 1 to 3

When flanges covered by this standard are intended for services with light wall, higher strength pipe, the thickness of the hub at the bevel may be greater than that of the pipe to which the flange is joined. Under these conditions a single taper hub may be provided and the outside diameter of the hub at the base (Dimension X) may also be modified.

The additional thickness may be provided on either inside or outside or partially on each side, but the total additional thickness shall not exceed one-half times the nominal wall thickness of intended mating pipe

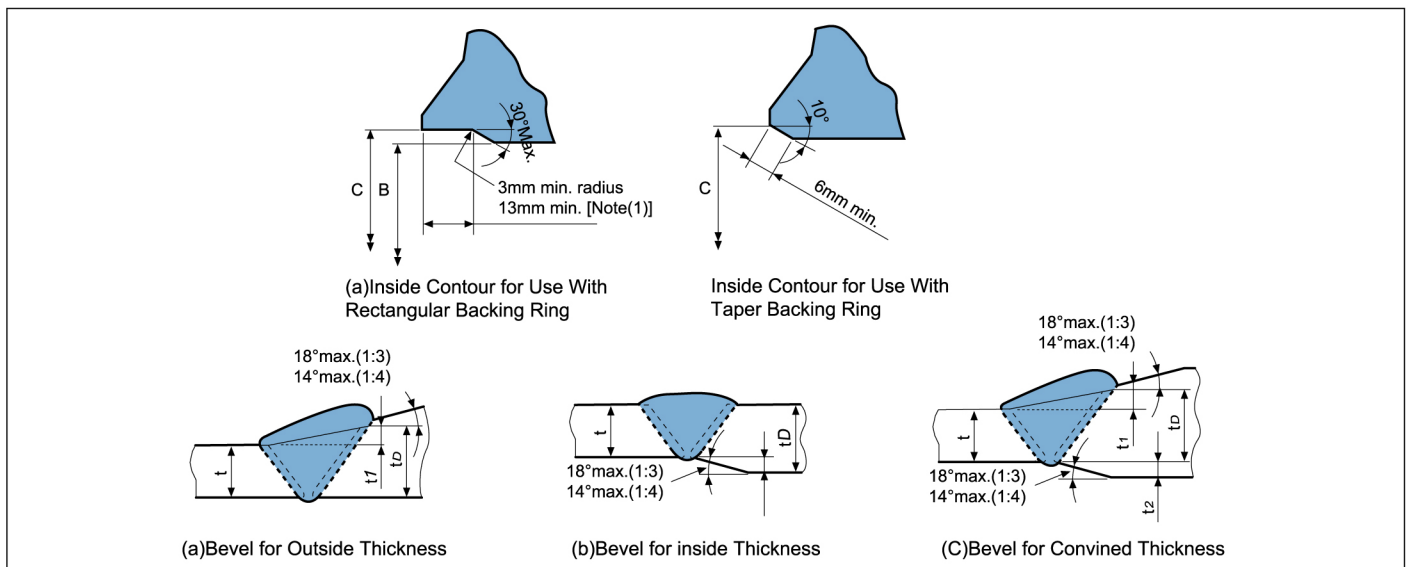

**Notes :**

- (1) When the materials joined have equal minimum specified yield strength, there shall be no restriction on the minimum slope.
- (2) Neither t1, t2, t3 nor their sum (t1 + t2) shall exceed 0.5t
- (3) When the minimum specified yield strengths of the sections to be joined are unequal, the value of t shall at least equal t time the ratio of minimum specified yield strength of the pipe to minimum specified yield strength of the flange.

# PIPE&FITTINGS WALL THICKNESS SCHEDULES DIMENSION

Nominal Pipe Size		Outside Diam.	Wall I.D.	Nominal Wall Thickness (Stainless steel)					Nominal Wall Thickness (Carbon & Low Alloy Steel)			
A	B			S5S*	S10S*	S20S	S40S	S80S	S5	S10	S20	S30
6	1/8	10.3	W.T	-	1.24	-	1.73	2.41	-	1.24	-	1.45
			I.D	-	7.82	-	6.84	5.48	-	7.82	-	7.40
8	1/4	13.7	W.T	-	1.65	-	2.24	3.02	-	1.65	-	1.85
			I.D	-	10.40	-	9.22	7.66	-	10.40	-	10.00
10	3/8	17.1	W.T	-	1.65	-	2.31	3.20	-	1.65	-	1.85
			I.D	-	13.80	-	12.48	10.70	-	13.80	-	13.40
15	1/2	21.3	W.T	1.65	2.11	-	2.77	3.73	1.65	2.11	-	2.41
			I.D	18.00	17.08	-	15.76	13.84	18.00	17.08	-	16.48
20	3/4	26.7	W.T	1.65	2.11	-	2.87	3.91	1.65	2.11	-	2.41
			I.D	23.40	22.48	-	20.96	18.88	23.40	22.48	-	21.88
25	1	33.4	W.T	1.65	2.77	-	3.38	4.55	1.65	2.77	-	2.90
			I.D	30.10	27.86	-	26.64	24.30	30.10	27.86	-	27.60
32	1 1/4	42.2	W.T	1.65	2.77	-	3.56	4.85	1.65	2.77	-	2.97
			I.D	38.90	36.66	-	35.08	32.50	38.90	36.66	-	36.26
40	1 1/2	48.3	W.T	1.65	2.77	-	3.68	5.08	1.65	2.77	-	3.18
			I.D	45.00	42.76	-	40.94	38.14	45.00	42.76	-	41.94
50	2	60.3	W.T	1.65	2.77	-	3.91	5.54	1.65	2.77	-	3.18
			I.D	57.00	54.76	-	52.48	49.22	57.00	54.76	-	53.94
65	2 1/2	73.0	W.T	2.11	3.05	-	5.16	7.01	2.11	3.05	-	4.78
			I.D	68.78	66.90	-	62.68	58.98	68.78	66.90	-	63.44
80	3	88.9	W.T	2.11	3.05	-	5.49	7.62	2.11	3.05	-	4.78
			I.D	84.68	82.80	-	77.92	73.66	84.68	82.80	-	79.34
90	3 1/2	101.6	W.T	2.11	3.05	-	5.74	8.08	2.11	3.05	-	4.78
			I.D	97.38	95.50	-	90.12	85.44	97.38	95.50	-	92.04
100	4	114.3	W.T	2.11	3.05	-	6.02	8.56	2.11	3.05	-	4.78
			I.D	110.08	108.20	-	102.26	97.18	110.08	108.20	-	104.74
125	5	141.3	W.T	2.77	3.40	-	6.55	9.53	2.77	3.40	-	-
			I.D	135.76	134.50	-	128.20	122.24	135.76	134.50	-	-
150	6	168.3	W.T	2.77	3.40	-	7.11	10.97	2.77	3.40	-	-
			I.D	162.76	161.50	-	154.08	146.36	162.76	161.50	-	-
200	8	219.1	W.T	2.77	3.76	-	8.18	12.70	2.77	3.76	6.35	7.04
			I.D	213.56	211.58	-	202.74	193.70	213.56	211.58	20.640	205.02
250	10	273.1	W.T	3.40	4.19	-	9.27	12.70	3.40	4.19	6.35	7.80
			I.D	266.30	264.72	-	254.56	247.70	266.30	264.72	260.40	257.50
300	12	323.9	W.T	3.96	4.57	-	9.53	12.70	3.96	4.57	6.35	8.38
			I.D	315.98	314.76	-	304.84	298.50	315.98	314.76	311.20	307.14
350	14	355.6	W.T	3.96	4.78	-	9.53	12.70	3.96	6.35	7.92	9.53
			I.D	347.68	346.04	-	336.54	330.20	347.68	342.90	339.76	336.54
400	16	406.4	W.T	4.19	4.78	-	9.53	12.70	4.19	6.35	7.92	9.53
			I.D	398.02	396.84	-	387.34	381.00	398.02	393.70	390.56	387.34
450	18	457.0	W.T	4.19	4.78	-	9.53	12.70	4.19	6.35	7.92	11.13
			I.D	448.62	447.44	-	437.94	431.60	448.62	444.30	441.16	434.74
500	20	508.0	W.T	4.78	5.54	7.90	9.53	12.70	4.78	6.35	9.53	12.70
			I.D	498.44	496.62	492.20	488.94	482.60	498.44	495.30	488.94	482.60
550	22	559.0	W.T	4.78	5.54	-	-	-	4.78	6.35	9.53	12.70
			I.D	549.44	547.92	-	-	-	549.44	546.30	539.34	533.60
600	24	610.0	W.T	5.54	6.35	-	9.53	12.70	5.54	6.35	9.53	14.27
			I.D	598.92	597.30	-	590.94	584.60	598.92	597.30	590.94	581.46

● Carbon & Low Alloy Steel (B36.10M)

The wall thickness shown represent nominal or average wall dimensions which are subject to a-12 1/2% mill tolerance.

Note that schedule 40 in. size 12" (304.8mm) and larger and that schedule 80 in. size 10" (254mm) and larger do not agree with schedules 40S and 80S of ANSI B36.19 nor with standard weight and extra strong respectively.



# ASME B36.10M & ASME B36.19M - 2004

-Nominal Wall Thickness (Carbon & Low Alloy Steel)-										Outside Diam.	Nominal Pipe Size	
STD	S40	S60	XS	S80	S100	S120	S140	S160	XXS		A	B
1.73	1.73	-	2.41	2.41	-	-	-	-	-	10.3	6	1/8
6.84	6.84	-	5.48	5.48	-	-	-	-	-			
2.24	2.24	-	3.02	3.02	-	-	-	-	-	13.7	8	1/4
9.22	9.22	-	7.66	7.66	-	-	-	-	-			
2.31	2.31	-	3.20	3.20	-	-	-	-	-	17.1	10	3/8
12.48	12.48	-	10.70	10.70	-	-	-	-	-			
2.77	2.77	-	3.73	3.73	-	-	-	4.78	7.47	21.3	15	1/2
15.76	15.76	-	13.84	13.84	-	-	-	11.74	6.36			
2.87	2.87	-	3.91	3.91	-	-	-	5.56	7.82	26.7	20	3/4
20.96	20.96	-	18.88	18.88	-	-	-	15.58	11.06			
3.38	3.38	-	4.55	4.55	-	-	-	6.35	9.09	33.4	25	1
26.64	26.64	-	24.30	24.30	-	-	-	20.70	15.22			
3.56	3.56	-	4.85	4.85	-	-	-	6.35	9.70	42.2	32	1 1/4
35.08	35.08	-	32.50	32.50	-	-	-	29.50	22.80			
3.68	3.68	-	5.08	5.08	-	-	-	7.14	10.15	48.3	40	1 1/2
40.94	40.94	-	38.14	38.14	-	-	-	34.02	28.00			
3.91	3.91	-	5.54	5.54	-	-	-	8.74	11.07	60.3	50	2
52.46	52.48	-	49.22	49.22	-	-	-	42.82	38.16			
5.16	5.16	-	7.01	7.01	-	-	-	9.53	14.02	73.0	65	2 1/2
62.68	62.68	-	58.98	58.98	-	-	-	53.94	44.96			
5.49	5.49	-	7.62	7.62	-	-	-	11.13	15.24	88.9	80	3
77.92	77.92	-	73.66	73.66	-	-	-	66.64	58.24			
5.74	5.74	-	8.08	8.08	-	-	-	12.70	-	101.6	90	3 1/2
90.12	90.12	-	85.44	85.44	-	-	-	76.20	-			
6.02	6.02	-	8.56	8.56	-	11.13	-	13.49	17.12	114.3	100	4
102.26	102.26	-	97.18	97.18	-	92.04	-	87.32	80.06			
6.55	6.55	-	9.53	9.53	-	12.70	-	15.88	19.05	141.3	125	5
128.20	128.20	-	122.24	122.24	-	115.90	-	109.54	103.20			
7.11	7.11	-	10.97	10.97	-	14.27	-	18.26	21.95	168.3	150	6
154.08	154.08	-	146.36	146.36	-	139.76	-	131.78	124.40			
8.18	8.18	10.31	12.70	12.70	15.09	18.26	20.62	23.01	22.23	219.1	200	8
202.74	202.74	198.48	193.70	193.70	188.92	182.58	177.86	173.08	174.63			
9.27	9.27	12.70	12.70	15.09	18.26	21.44	25.40	28.58	25.40	273.1	250	10
254.56	254.56	247.70	247.70	242.92	236.58	230.22	222.30	215.94	222.30			
9.53	10.31	14.27	12.70	17.48	21.44	25.40	28.58	33.32	25.40	323.9	300	12
304.84	303.28	295.36	298.50	288.94	281.02	273.10	266.74	257.26	273.10			
9.53	11.13	15.09	12.70	19.05	23.83	27.79	31.75	35.71	-	355.6	350	14
336.54	333.34	325.42	330.20	317.50	307.94	300.02	292.10	284.18	-			
9.53	12.70	16.66	12.70	21.44	26.19	30.96	36.53	40.49	-	406.4	400	16
387.34	381.00	373.08	381.00	363.52	354.02	344.48	333.34	325.42	-			
9.53	14.27	19.05	12.70	23.83	29.36	34.93	39.67	45.24	-	457.0	450	18
437.94	428.46	418.90	431.60	409.34	398.28	387.14	377.66	366.52	-			
9.53	15.09	20.62	12.70	26.19	32.54	38.10	44.45	50.01	-	508.0	500	20
488.94	477.82	466.76	482.60	455.62	442.92	431.80	419.10	407.98	-			
9.53	-	22.23	12.70	28.58	34.93	41.28	47.63	53.98	-	559.0	550	22
539.94	-	514.54	533.60	501.84	489.14	476.44	463.74	451.04	-			
9.53	17.48	24.61	12.70	30.96	38.89	46.02	52.37	59.54	-	610.0	600	24
590.94	575.04	560.78	584.60	548.08	532.22	517.96	505.26	490.92	-			

● **Stainless steel (B36.19M)**

The wall thickness shown represent nominal or average wall dimensions which are subject to a-12 1/2% mill tolerance.

+Size 14"(355.6mm) through 30"(762.0mm) are not at publication data covered in B36.19, and dimensions listed are those commonly used in the industry.

\*Schedules 5S and 10S wall thicknesses do not permit threading in accordance with ASME B2 1.

\*\*Note that schedule 40S and schedule 80S in these sizes do not agree with schedule 40 and schedule 80 of ASME B36.10, and that they are identical to standard weight and extra strong respectively of ASME B36.10.